

**Slim Bezel Case Dimensions and Panel Cutouts**

**STANDARD SLIM BEZEL CASE**

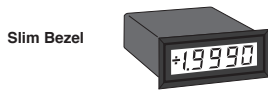

**SLIM BEZEL CASE**  
Standard Black ABS case with matte finish bezel for single unit mounting.  
Part No. **SL-CASERED** for LED's  
**SL-CASECLR** for LCD's

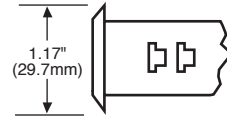

**OPTIONAL TWIN MOUNTING OR MULTIPLE ARRAY CASES**



**END MOUNT CASE**  
Same styling as Slim Bezel case but with bottom edge of bezel removed. Two End Mount cases can be twin mounted in a single cutout.  
Part No. **EM-CASERED** for LED's  
**EM-CASECLR** for LCD's

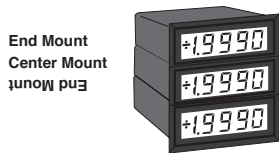
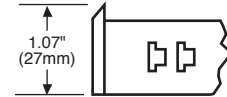

**CENTER MOUNT CASE**  
Any number of Center Mount cases may be fitted between two End Mount cases for multiple arrays.  
Part No. **CM-CASERED** for LED's  
**CM-CASECLR** for LCD's

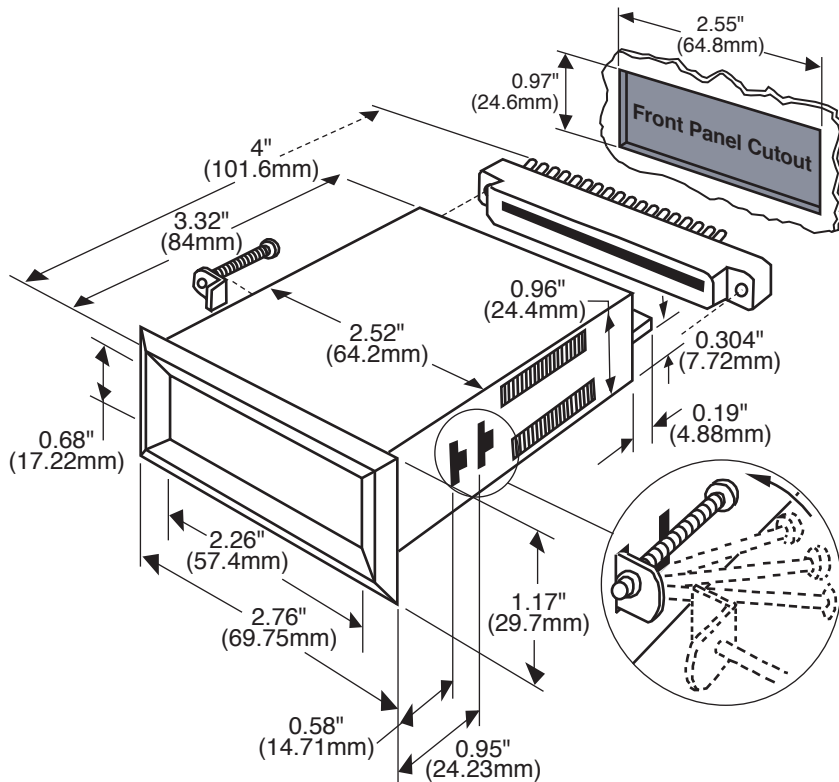

Insert dpm through cutout hole from front of panel. Attach mounting brackets and screws as shown, using second slot when panel thickness is greater than 1/4 inch. Tighten screws against rear of panel.