

**1/16 DIN 96x24mm (3.78"x0.95") Short Depth Case Dimensions and Panel Cutout**

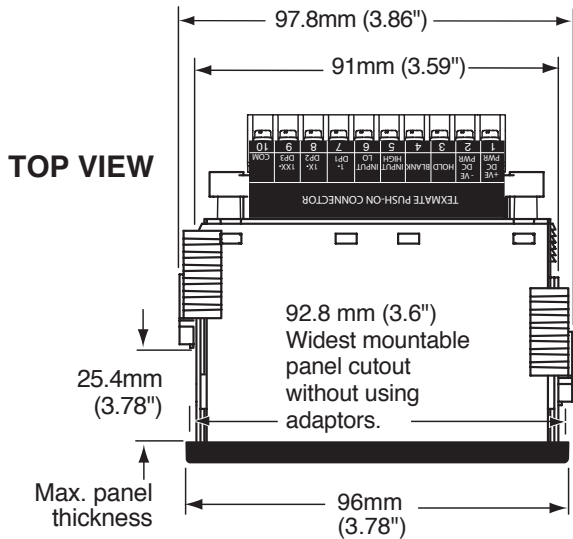

**PANEL CUTOUT**

Case will mount in standard 1/16 DIN cutouts

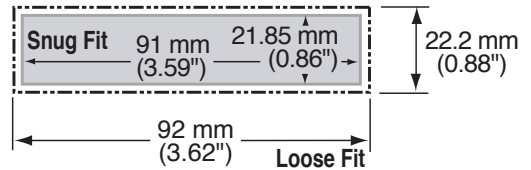

**Panel adaptor plates are available to retrofit most existing panel cutouts.**

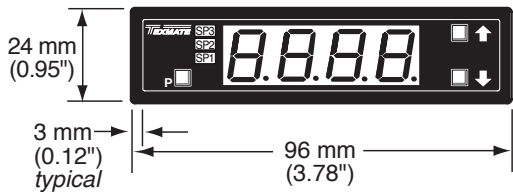

**FRONT VIEW**  
1/16 DIN (96x24mm)

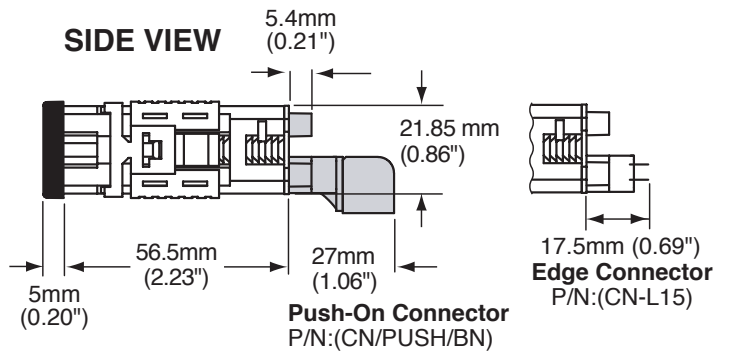

For additional strength, extra Mounting Slide Clips can be ordered and doubled up one behind the other.  
P/N:(75-DMT96X24)

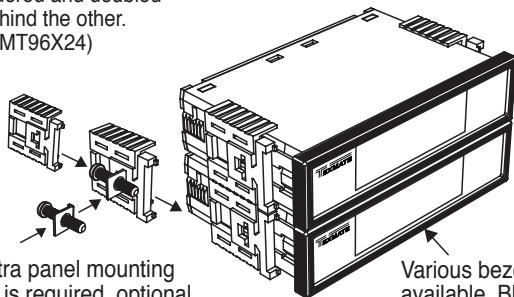

When extra panel mounting tightness is required, optional Screw Mounting Clips are included which fit on the Mounting Slide Clips.

Various bezel colors are available. Black is standard.

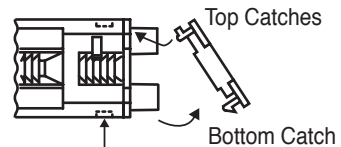

Release Bottom Catch with a small flat blade, and lever outwards.

**TO REMOVE REAR COVER**

The 96x24mm case is particularly suitable for mounting in mosaic panels or insulative panels. They can also stack mount, 2 up in existing cut-outs for 1/8 DIN (96x48mm) or 4 up in 1/4 DIN (96x96mm).

