

MAGNETOSTRICTIVE SMART INPUT MODULE

MAGNETOSTRICTIVE

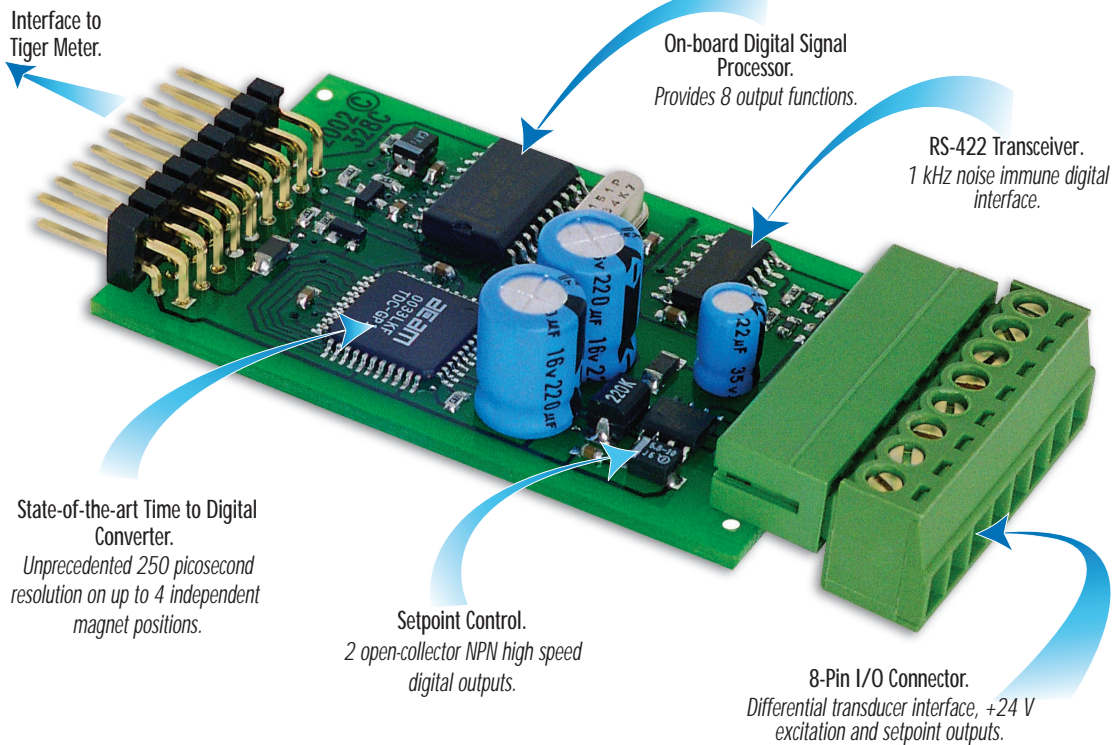

Solutions in time for ultra-precise contact-less registration of linear displacement.

Redefining linear displacement measurements, the ISM1 smart input module provides sub-micro meter resolution over the entire length of the positioning equipment. Interfaced with industry standard micro-pulse magnetorestrictive transducers, the combination of the ISM1 and the Tiger 320 operating system deliver four independent linear displacements, four independent rates of change, and two high speed setpoint controls.

Input Module
Order Code Suffix

ISM1



Hardware Module Specifications	
TDC	ACAM Time-to-digital convertor 250 ps time resolution (typical).
Displacement Resolution	In principle 0.7 μm or equivalently 28 millionth of an inch.
Multi-hit Capability	Up to 4 independent floating magnets read concurrently (representing 4 displacements).
Transducer Interface	RS422 differential for interrogate & pulse.
Sample Rate	Stroke length dependent: 1 kHz < 2000 mm stroke 500 Hz > 2000 mm stroke.
Transducer Type	Designed to operate with digital interface leading/trailing-edge pulse magnetostriuctive transducers. *
Digital Outputs	Two latched digital outputs available (open-collector NPN transistor type) operated from Tiger setpoints SP5 & SP6.

Macro Software Inputs	
Gradient ($\mu\text{s}/\text{inch}$)	Resolution correction for independent transducer scale factors.
Units	Select inches or millimeters.
Transducer Type	Enter leading or trailing edge received pulse format.
Displacement	Selectable 1-4 independent position calculations.
Velocity	Selectable 1-4 independent velocity calculations.
Sample Rate	1 kHz, 500 Hz or 200 Hz available.
Setpoint Control	Choice of 8 setpoint sources and inverted logic for latched digital outputs.

* Note, for a quadrature interface option, please see Texmate's Quadrature Smart Input Module IC02/IC03 on data sheet (NZ329).

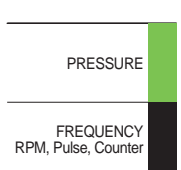
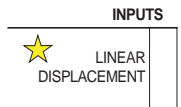

Connecting the ISM1 to a Magnetostrictive Transducer

The Texmate ISM1 magnetostrictive smart input module is designed to operate with most digital interface leading/trailing-edge pulse magnetostrictive transducers. These include the following manufacturers of magnetostrictive transducers:

- Balluff.
- Gefran.
- MTS Systems Corporation.
- Novotechnik.
- Patriot Sensors and Controls Corporation.
- SanTest.
- TR Electronic.

As an example, the ISM1 magnetostrictive smart input module, shown in Figure 1, interfaces directly with and supplies +24 V excitation voltage to a Balluff micropulse P-style magnetostrictive transducer. The ISM1 can be configured to receive either trailing-edge active (P Balluff option) or leading-edge active (M Balluff option) pulses.

Note, the ISM1 only supports the P and M digital RS-422 output interface options.

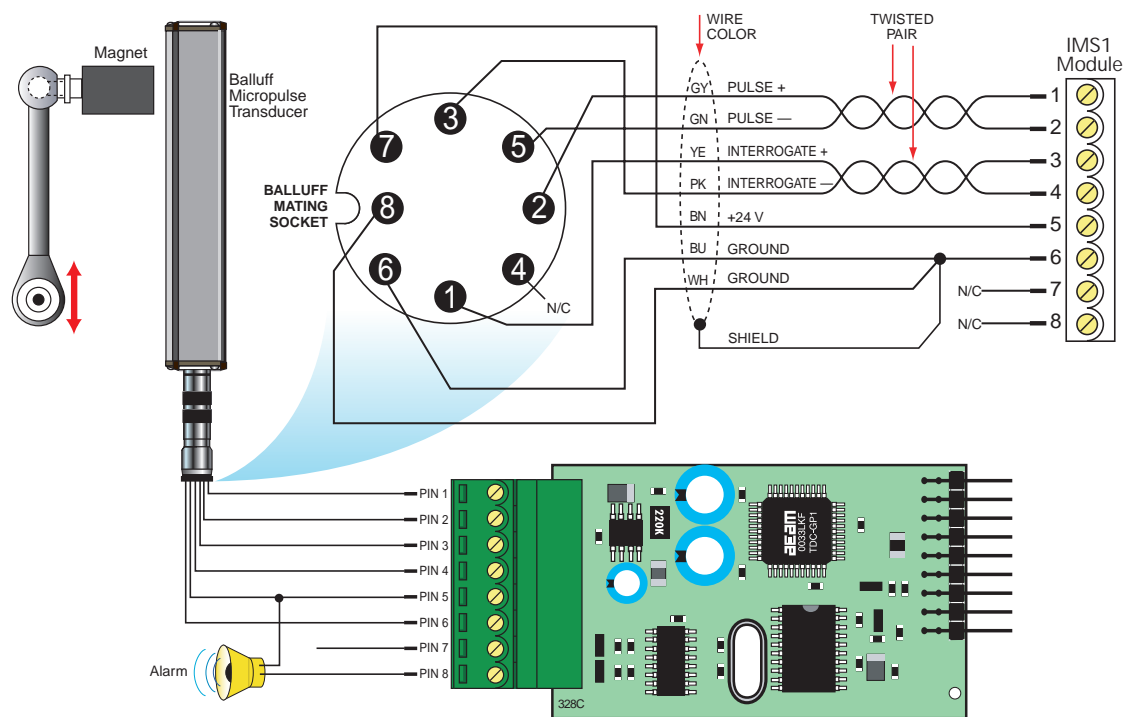

Level monitoring using a Balluff Micropulse transducer connected to the ISM1 module. Setpoint 5 (SP5) is connected as an alarm

Figure 1 – Magnetostriuctive Input Module ISM1 connected to Balluff Micropulse Transducer

Input Module Setup

All setup procedures are carried out by Texmate prior to shipping. Customers are responsible for pinout connections between the controller and the sensor.

Smart Setup Registers

Texmate have a range of smart input modules that require programming through the controller's programming modes. The meter has three smart setup registers available to configure the installed smart input module. Input module ISM1 requires only smart registers 1 and 2 to be set up. The ISM1 input module is configured for trailing/leading-edge active received pulses, sample rate, number of magnet positions, required number of velocities, and setpoint controlled outputs.

Figure 2 shows the logic flow through the ISM1 smart input module.

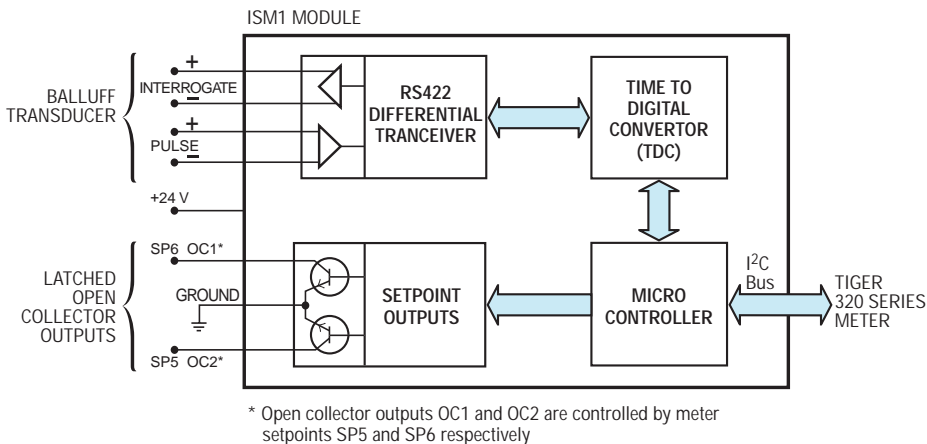

Figure 2 – ISM1 Logic Flow Diagram

Macro Programming

Prior to shipping, Texmate configures the controller with a **macro**. The macro automates the programmable functions available in the controller to perform our customers requested functions. The macro is programmed on a PC using Texmate's in-house development software program, known as the Tiger Development System (TDS) compiler program. The TDS compiler saves the macro as a .bas file that is then downloaded to the controller.

Tiger Macro Development System (TDS)

Tiger 320 Macro Overview

The Tiger 320 Series of programmable meter controllers have been designed to incorporate the analog and digital functionality of an intelligent controller with the logic of a PLC.

Traditionally, the PLC approach is to build a working application entirely in some form of programming language. The approach used in the Tiger 320 Series of controllers is to build an application by selecting the pre-programmed functions of the controller and then adding small amounts of programmability and logic where needed.

The operating system of the Tiger 320 controller controls all the pre-programmed functions, handling the input, averaging, scaling, linearization, totalization and much more, as well as driving the display, timers, relays, analog and serial outputs. Once configured, these functions are executed by the operating system and form the basis of a control system.

To form an advanced automation and control system you only need to write a small program that adds the extra logic required. We call this program a macro. A macro can be written specifically for your application and is used to initiate a sequence, reconfigure, or disable some of the controller functions. With Texmate's 22 I/O plug-in module installed, a macro further expands the Tiger 320 operating system with additional digital status inputs and digital switched outputs.

Macro control is ideal for many OEM applications that require analog, digital, and timer functions with sophisticated mathematical and enhanced logic operations. The macro concept has major cost advantages for large or small sophisticated applications that require some degree of programmable logic control with display and front panel control.

Custom Macro Programming

Texmate's Tiger Development System (TDS) enables a macro to be written and compiled in BASIC, utilizing any combination of the hundreds of functions and thousands of registers embedded in the Tiger 320 Operating System. When your BASIC program is compiled into Tiger 320 Macro-language it is error checked and optimized.

Macros are useful when implementing a specialized control system that cannot be achieved by the standard configuration capability of the Tiger 320 Operating System. Using the TDS software, functions can be altered or added in a standard controller to perform the required job. This may typically include logic sequencing functions and mathematical functions.

Developing a Macro is much easier and quicker than programming a PLC, because the basic code required to customize the Tiger meter is considerably less than the ladder logic programming required for PLCs. This is due to the hundreds of functions built into the Tiger controller that can be manipulated or invoked by a macro to fulfill the requirements of almost any application.

Scrolling display messages can be programmed to appear with any setpoint activation, selected event, or logic input. Easy to read, plain text prompts can be programmed to replace the manual programming codes and provide a user-friendly interface for any custom application.

Scrolling Text Messaging

Scrolling text messaging is another bonus from running a macro. Any number of messages for detailed operator instructions, of up to 100 characters each, can be written into the macro during compilation for detailed operator instructions, alarm and control applications.

A scrolling text message can be written for OEMs and sensor manufacturers providing informative instructions for setup and calibration procedures.



Alphanumeric Displays

14-segment alphanumeric displays are Texmate's display choice for easy to read display text and scrolling text messaging.



Customer Configuration Settings:

	1st Digit	2nd Digit	3rd Digit				
	5	7	t	1			
	1st Digit	2nd Digit	3rd Digit				
CH1	Cod_2						
	1st Digit	2nd Digit	3rd Digit				
CH2	Cod_4	0	0				
	1st Digit	2nd Digit	3rd Digit				
CH3	Cod_5	7					
	1st Digit	2nd Digit	3rd Digit				
CH4	Cod_6	7					
	1st Digit	2nd Digit	3rd Digit				

WARRANTY

Texmate warrants that its products are free from defects in material and workmanship under normal use and service for a period of one year from date of shipment. Texmate's obligations under this warranty are limited to replacement or repair, at its option, at its factory, of any of the products which shall, within the applicable period after shipment, be returned to Texmate's facility, transportation charges pre-paid, and which are, after examination, disclosed to the satisfaction of Texmate to be thus defective. The warranty shall not apply to any equipment which shall have been repaired or altered, except by Texmate, or which shall have been subjected to misuse, negligence, or accident. In no case shall Texmate's liability exceed the original purchase price. The aforementioned provisions do not extend the original warranty period of any product which has been either repaired or replaced by Texmate.

USER'S RESPONSIBILITY

We are pleased to offer suggestions on the use of our various products either by way of printed matter or through direct contact with our sales/application engineering staff. However, since we have no control over the use of our products once they are shipped, NO WARRANTY WHETHER OF MERCHANTABILITY, FITNESS FOR PURPOSE, OR OTHERWISE is made beyond the repair, replacement, or refund of purchase price at the sole discretion of Texmate. Users shall determine the suitability of the product for the intended application before using, and the users assume all risk and liability whatsoever in connection therewith, regardless of any of our suggestions or statements as to application or construction. In no event shall Texmate's liability, in law or otherwise, be in excess of the purchase price of the product.

Texmate cannot assume responsibility for any circuitry described. No circuit patent or software licenses are implied. Texmate reserves the right to change circuitry, operating software, specifications, and prices without notice at any time.



Tel: 1-760-598-9899 • USA 1-800-839-6283 • That's 1-800-TEXMATE
 Fax: 1-760-598-9828 • Email: sales@texmate.com • Web: www.texmate.com

Texmate has facilities in Japan, New Zealand, Taiwan, and Thailand. We also have authorized distributors throughout the USA and in 28 other countries.

For product details visit www.texmate.com
 Local Distributor Address