

1/16 DIN 96x24mm (3.78"x0.95") Case Dimensions and Panel Cutout

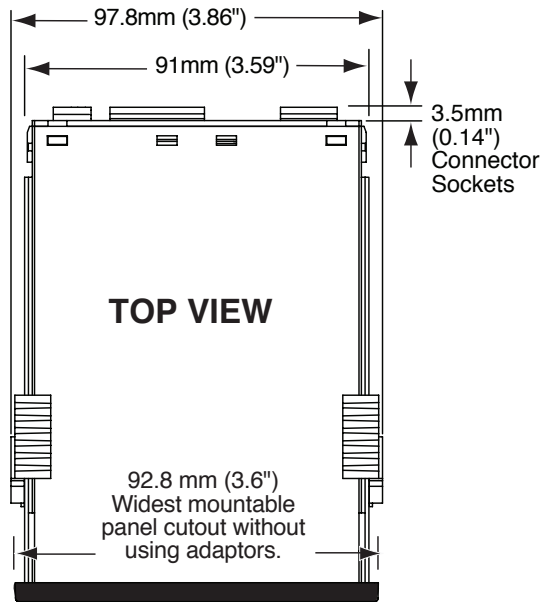

PANEL CUTOUT
Case will mount in standard 1/16 DIN cutouts

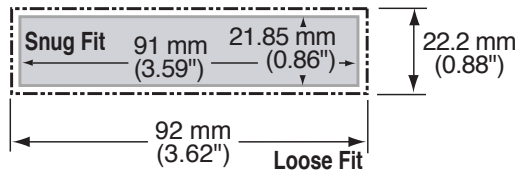

Panel adaptor plates are available to retrofit most existing panel cutouts.

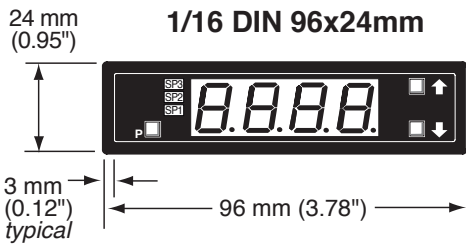

FRONT VIEW

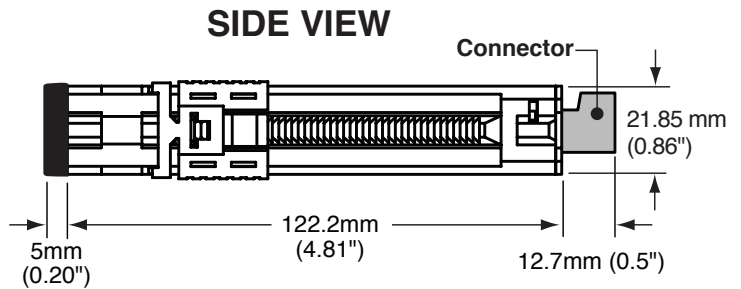

SIDE VIEW

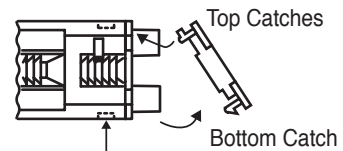

Release Bottom Catch with a small flat blade, and lever outwards.

TO REMOVE REAR COVER

For additional strength, extra **Mounting Slide Clips** can be ordered and doubled up one behind the other. (P/N: 75-DMT96X24)

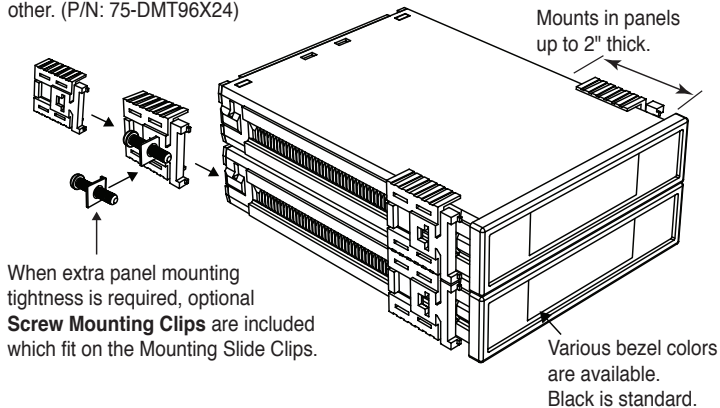

When extra panel mounting tightness is required, optional **Screw Mounting Clips** are included which fit on the Mounting Slide Clips.

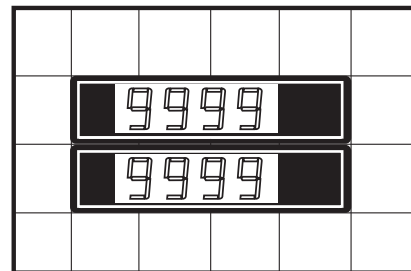

Texmate's 96x24mm case is particularly suitable for mounting in mosaic panels or insulative panels up to 2" thick. They can also stack mount, 2 up in existing cut-outs for 1/8 DIN (96x48mm) or 4 up in 1/4 DIN (96x96mm).