



DX-45-DCA

**20/50/100/200mV DC Full Scale
4 1/2 Digit with 0.56" LEDs
in a 1/8 DIN Case**

Measuring DC signals as low as 20mV full scale, this meter is ideal for use with low voltage drop current shunts or other precision low DC measurements.

General Features

The DX-45-DCA is a cost-effective, low DC voltage measuring meter with four header selectable full scale ranges of 20mV, 50mV, 100mV(standard) and 200mV. The meter is particularly suited for measuring DC current using 50mV standard current shunts. After selecting a new range, re-calibration is required. Display Hold and Display Test functions are also provided. The standard meter has a high efficiency red LED.

Typical Application Connections

DC Current measurement using a 50mV Shunt. Easily user scaled to display currents up to 19999 Amps.

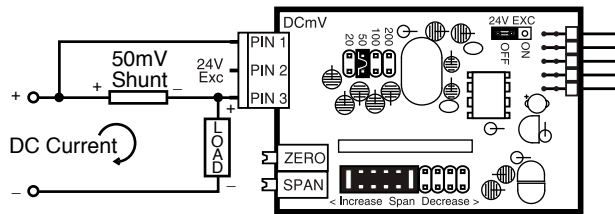

Shunt may be in Hi or Lo side of Load.

DC mV measurement with a resolution of 100 microVolts. Easily user scaled to display voltages up to 199.99 mV.

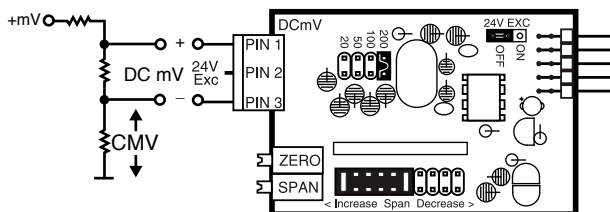

Can be used to measure single-ended or differential inputs. Max CMV (common mode voltage) is 50V*. Because CMV is common with meter ground, higher CMV inputs to a max of 1KV require mechanical isolation of all contactable meter parts.

Compatibility

The DX-Series have a matching DIN case style that is complementary to the Leopard and Tiger family of meters. DX-Meters are the OEM's choice for switchboard and process indication. Each model is dedicated to a specific application and designed for quick and easy installation.



Specifications

- Input Configuration:**..... Single-ended, however isolated power supply enables differential measurements up to a maximum common mode of 50V.*
- Full Scale Ranges:**..... Four header selectable ranges of $\pm 20\text{mV}$ DC, $\pm 50\text{mV}$ DC, $\pm 100\text{mV}$ DC & $\pm 200\text{mV}$ DC full scale
- Input Impedance:**..... 50K Ω /100K Ω /65K Ω in 50/100/200 ranges
- A/D Converter:**..... 16 Bit Dual Slope
- Accuracy:**..... $\pm (0.05\%$ of reading + 3 digits)
- Temperature Coefficient:** 100ppm/ $^{\circ}\text{C}$ (Typical)
- Warm Up Time:**..... One minute to specified accuracy
- Conversion Rate:**..... 3 readings per second
- Display:**..... **4 1/2 digit 0.56" Red LED display(std)**, 0.56" Green or Super Bright Red (optn). Display Hold & Display Test are provided.
- Polarity:**..... Bipolar. Assumed positive, displays negative
- Decimal Selection:**..... Header under face plate, X·X·X·X·X
- Positive Overrange:**..... All 0000 flash.
- Negative Overrange:**..... Negative sign - and all 0000 flash.
- Power Supply:**..... AC/DC Auto sensing wide range supply
PS1 (std)..... 85-265 VAC, 50-400Hz / 95-300 VDC @1.5W
PS2..... 15-48 VAC, 50-400Hz / 10-72 VDC @4.0W
- Operating Temperature:**... 0 to 50 $^{\circ}\text{C}$
- Storage Temperature:**..... -20 to 70 $^{\circ}\text{C}$
- Relative Humidity:**..... 95% (non-condensing)
- Case Dimensions:**..... 1/8 DIN, Bezel: 96x48mm (3.78"x1.89")
 Depth behind bezel 117 mm (4.61") plus 11.8mm (0.47") for Right-angled Connector or 20mm (0.79") for Straight-through Connectors.
- Weight:**..... 11 oz., 14 oz when packed
- Certification:**..... UL Listed

DX-Series, the OEMs choice for switchboard and process indication

- DX-35-DCV**..... DC volts $\pm 2\text{V}/\pm 20\text{V}/\pm 200\text{V}$ Header Selectable Ranges, 3.5 digit
- DX-35-DCA**..... DC mV $\pm 50\text{mV}$, $\pm 100\text{mV}$, $\pm 200\text{mV}$ Header Selectable Ranges, 3.5 digit
- DX-35-ACV**..... AC volts, Scaled RMS (True RMS Opt.). 199.9/300V AC Header Selectable Ranges, 3.5 digit
- DX-35-ACA**..... AC amps, Scales RMS (True RMS Opt.). (5 Amp Internal Shunt), 3.5 digit
- DX-35-CL**..... Process 4 to 20mA (100.0), easily user scalable, 3.5 digit w/Exc. opt
- DX-35-HZ**..... AC Line Frequency 15.0Hz to 199.9Hz. Up to 300V AC input, 3.5 digit

- DX-35-TC-KF**..... K Thermocouple with $^{\circ}\text{F}$, optional $^{\circ}\text{C}$, 3.5 digit
- DX-35-TC-JF**..... J Thermocouple with $^{\circ}\text{F}$, optional $^{\circ}\text{C}$, 3.5 digit
- DX-35-RTD-F**..... 100 Ω platinum RTD, 3 or 4 wire, $^{\circ}\text{F}$ in 1 $^{\circ}$ resolution, optional $^{\circ}\text{C}$, 3.5 digit
- DX-40-ACV**..... AC volts, Scaled RMS (True RMS Opt.). 300.0V AC full scale, 4 digit
- DX-45-ACA**..... AC amps, Scaled RMS (True RMS Opt.). (5 Amp Internal shunt), 4.5 digit
- DX-45-DCV**..... DC volts $\pm 2\text{V}/\pm 20\text{V}/\pm 200\text{V}$ Header Selectable Ranges, 4.5 digit
- DX-45-DCA**..... DC mV $\pm 50\text{mV}/\pm 100\text{mV}/\pm 200\text{mV}$ Header Selectable Ranges, 4.5 digit
- DX-45-CL**..... Process 4 to 20mA (100.0), easily user scalable, 4.5 digit w/Exc. opt.

Connector Pinouts

This meter uses plug-in type screw terminal connectors for all connections.

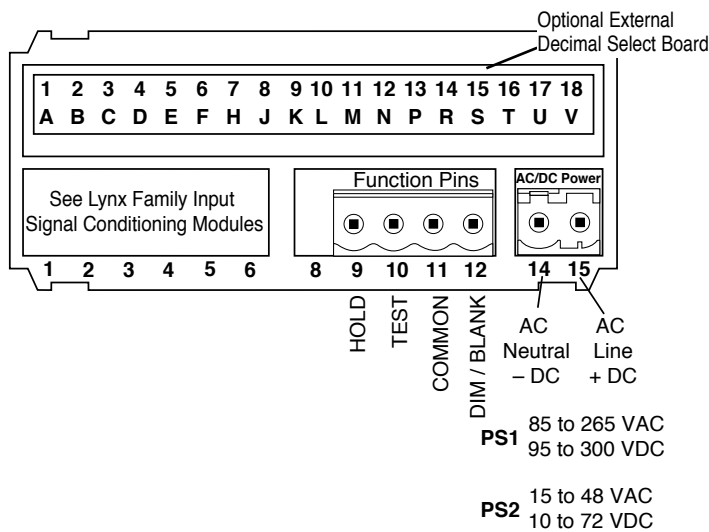

Pin Descriptions

Pin 1 - Signal Input High: Signal high input for the meter. Full scale ranges of 20/50/100/200 mV DC can be selected on the Range Select Header.

Pin2-24V Excitation: 24V Excitation when selected on module.

Pin3-Signal Input Low: Signal low input for the meter.

Pin 9 - Hold: If this pin is left unconnected the meter will operate in a free running mode. When this pin is connected to the Common Pin 11, the meter display will be latched. A/D conversions will continue, but the display will not be updated until Pin 9 is disconnected from Pin 11.

Pin 10 - Display Test: When this pin is connected to the Common Pin 11, all segments of the display light up and 1888 is displayed. This is used to detect any missing segments in the display.

Pin 11 - Common: To Hold, Test or Dim the display, the respective pins have to be connected to this Common Pin.

Pin 12 - Dim/Blank: When this pin is connected to the Common Pin 11 the display is blanked out. If it is connected through an external 1KΩ pot, the display may be dimmed.

Pin 14 & 15 - AC/DC Power Input: These pins are the power pins of the meter and they only accept a special polarized screw terminal plug that can not be inserted into any other input socket. The standard meter has a auto sensing AC/DC power supply that operates from 85-265 VAC/95-300 VDC (PS1 Std). An optional isolated low voltage power supply that operates from 15-48 VAC/10-72 VDC (PS2) is also available.

OPTIONAL EXTERNAL DECIMAL POINT SELECTION BOARD

Pins 6, F - Decimal Common: Connect to these pins to activate decimals.

Pins 7, H - Decimal XXXX.: Connect to pin 6 or pin F to activate decimal XXXX..

Pins 8, J - Decimal XXX.X: Connect to pin 6 or pin F to activate decimal XXX.X.

Pins 9, K - Decimal XX.XX: Connect to pin 6 or pin F to activate decimal XX.XX.

Pins 10, L - Decimal X.XXX: Connect to pin 6 or pin F to activate decimal X.XXX.

Calibration Procedure

1. Select the required full scale voltage range, by repositioning the jumper clip on the range select header.
2. Apply an input of 0 millivolts. Adjust the zero offset pot until the meter reads 000.
4. Apply a known high input signal that is within the full scale voltage range selected.
5. Adjust the Span Pot until the meter displays the required reading for the signal being applied.
6. The DX-45-DCA is now calibrated and ready for use.

(Whenever a new range is selected, re-calibration is required to meet the specified accuracy).

Component Layout

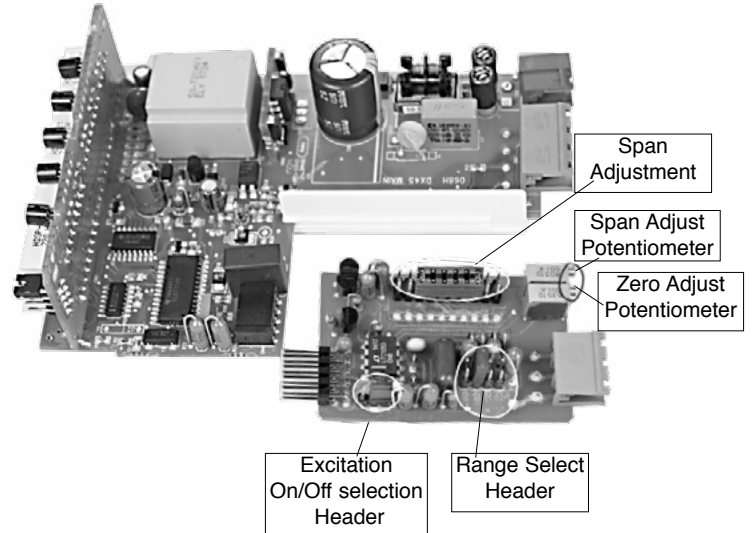

Signal Conditioning Components

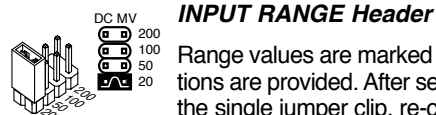

INPUT RANGE Header

Range values are marked on the PCB. Three positions are provided. After selecting a new range with the single jumper clip, re-calibration is required.

SPAN Potentiometer (Pot)

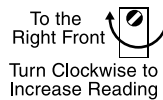

The 15 turn SPAN pot is always on the right side (as viewed from the front of the meter). Typical adjustment is 100% of the input signal range.

ZERO Potentiometer (Pot)

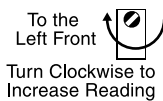

The ZERO pot is always to the left of the SPAN pot (as viewed from the front of the meter). Typically it enables the displayed reading to be offset ± 100 counts.

Opening Back Panel



To open back panel, insert a flat screwdriver or similar instrument in both slots on the top of the case and pry open. The DX-Series meters slide out from the rear of the case as a complete assembly.

DU Case Dimensions and Panel Cutouts

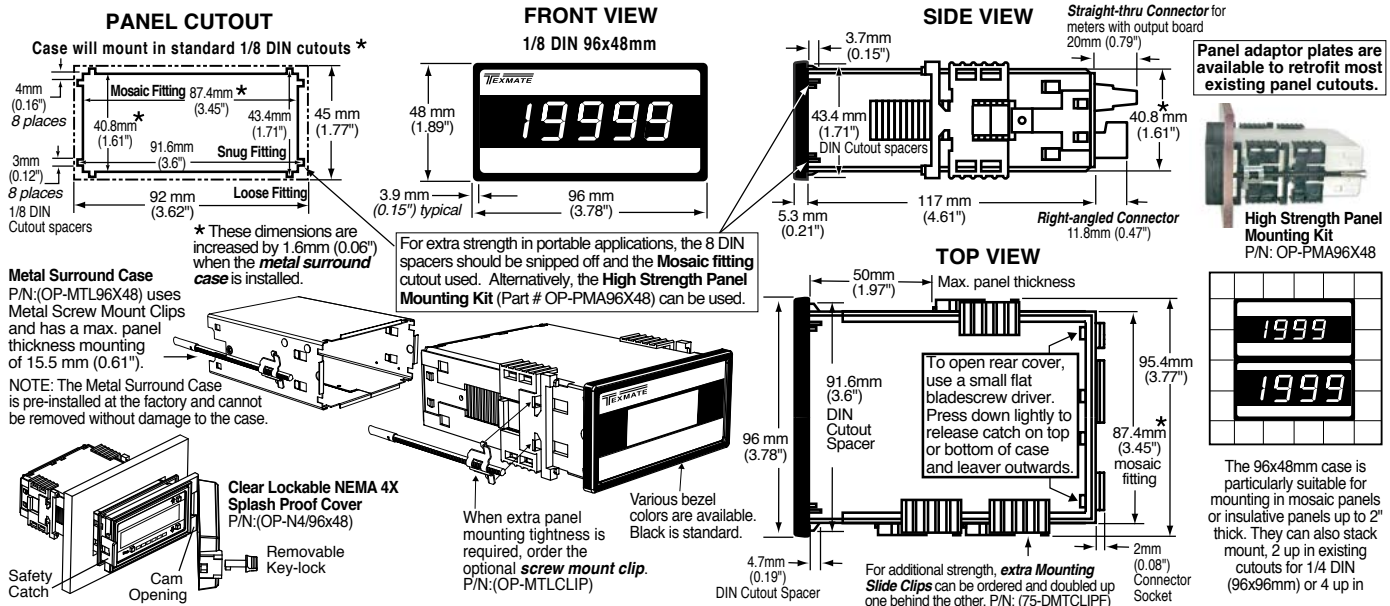

Ordering Information

Standard Options for this Model Number

Part Number	Description	List
► BASIC MODEL NUMBER Includes plug in type screw terminals, standard display and standard power supply unless optional versions are ordered.		
DX-45-DCA.....	DPM, DC mV ±20mV, ±50mV, ±100mV, ±200mV	
	Header selectable ranges	

► DISPLAY

DR . . . Red LED, 0.56 inch high	
DB . . . Super-bright Red LED, 0.56 inch high	
DG . . . Green LED, 0.56 inch high	

► POWER SUPPLY

PS1 . . 85-265VAC/95-300VDC	
PS2 . . 15-48VAC/10-72VDC	

Special Options and Accessories

Part Number	Description	List
► SPECIAL OPTIONS (Specify Inputs or Outputs & Req. Reading)		
CR-CHANGE . . .	Calibrated Range Change to another Standard Range . .	
CS-4.5/5/6	Custom display scaling within std. ranges	
OP-DXEXTDP . . .	External Dec. Pt. W/Conn. Option-Factory Installed . .	

► ACCESSORIES (Specify Serial # for Custom Artwork Installation)

75-DBBZ9648F . . .	Extra Black Bezel for 96x48mm Case	
75-DMTCLIPF . . .	Side Slide Brackets (2 pc) - extra set, extra strength	
76-D45G-N4	NEMA 4 Green LED Faceplate, Factory Installed	
76-D45R-N4	NEMA 4 Red LED Faceplate, Factory Installed	
CN-L18	Dual Row 18 Pin Edge Connector, Solder Type	
DN.CAS96X48B . . .	Complete 96 X 48 mm Case with bezel	
OP-MTLCLIP	Screw Mount Clips (2 pc) - to screw tighten slide brackets	
OP-MTL96X48 . . .	Metal Surround Case, includes screw mounting clips	
OP-N4X/96X48 . . .	96x48mm clear lockable front cover-NEMA 4X, splash proof	
OP-PSA/96X48 . . .	Panel to Case Seal Adapter with O-Ring and Foam Gasket	
DU-CASEDES . . .	Clear adhesive descriptors label for face plate	

WARRANTY

Texmate warrants that its products are free from defects in material and workmanship under normal use and service for a period of one year from date of shipment. Texmate's obligations under this warranty are limited to replacement or repair, at its option, at its factory, of any of the products which shall, within the applicable period after shipment, be returned to Texmate's facility, transportation charges pre-paid, and which are, after examination, disclosed to the satisfaction of Texmate to be thus defective. The warranty shall not apply to any equipment which shall have been repaired or altered, except by Texmate, or which shall have been subjected to misuse, negligence, or accident. In no case shall Texmate's liability exceed the original purchase price. The aforementioned provisions do not extend the original warranty period of any product which has been either repaired or replaced by Texmate.

USER'S RESPONSIBILITY

We are pleased to offer suggestions on the use of our various products either by way of printed matter or through direct contact with our sales/application engineering staff. However, since we have no control over the use of our products once they are shipped, NO WARRANTY WHETHER OF MERCHANTABILITY, FITNESS FOR PURPOSE, OR OTHERWISE is made beyond the repair, replacement, or refund of purchase price at the sole discretion of Texmate. Users shall determine the suitability of the product for the intended application before using, and the users assume all risk and liability whatsoever in connection therewith, regardless of any of our suggestions or statements as to application or construction. In no event shall Texmate's liability, in law or otherwise, be in excess of the purchase price of the product.

Texmate cannot assume responsibility for any circuitry described. No circuit patent or software licenses are implied. Texmate reserves the right to change circuitry, operating software, specifications, and prices without notice at any time.



450 State Place • Escondido, CA 92029
Tel: 1-760-598-9899 • USA 1-800-839-6283 • 1-800-TEXMATE
Fax: 1-760-598-9828 • Email: orders@texmate.com • Web: www.texmate.com

DX-45-DCA Technical Manual Copyright © 2018 Texmate Inc. All rights reserved. Published by: Texmate Inc. USA. Information in this Technical Manual is subject to change without notice due to correction or enhancement. The information described in this manual is proprietary to Texmate, Inc. and may not be copied, reproduced or transmitted, in whole or in part, in connection with the design, manufacture, or sale of apparatus, device or private label product without the express written consent of Texmate, Inc.