



LEOPARD FAMILY

FL-B101D40-TC FL-B101D40-RTD

Leopard Bargraph Temperature Meter

Smart Tri or mono-color digital bargraph with optional four fully programmable set points and optional analog output to measure J, K, R, and T type T/C or RTD inputs.



101 Segment, 4 Digit 0.32" LEDs in a 9/64 DIN CASE

General Features

- Thermocouple (J, K, R and T types) or RTD (Pt-100, 385 and 392 curves. 3 wire/4wire). Digitally Linearized.
- Optional isolated 16 bit analog output. User or factory scalable to 4 to 20 mA, 0 to 20 mA or 0 to 10 V across any desired digital span from \pm one count to the full scale range of -1999 to 9999 (12000 counts).
- A Programmable Tricolor (Red-Green-Orange) or mono color (red or green), 101 segment high brightness bargraph. Vertical or optional horizontal format.
- Front panel LED annunciators provide indication of setpoint status.
- Optional Two 9 Amp Form C, and two 4 Amp Form A relays available
- Auto-sensing AC/DC power supply. For voltages between **85-265 V AC / 95-300 V DC (PS1)** or 18-48 V AC / 10-72 V DC (PS2).
- Provision to connect an external programming lockout switch.
- Provision for external DIM switch to reduce the brightest display setting by 50%.
- Optional NEMA-4 front cover.
- Automatic intelligent averaging, smooths noisy signals while providing a fast display response to real level changes.

Software Features

- The bargraph can display, full scale, any desired portion of the digital reading.
- Four programmable setpoints.
- Setpoint 1 has delay-on-make and delay-on-break plus a special "pump on pump off" mode that creates a Hysteresis Band between SP1 and SP2.
- Relay activation can be selected to occur above (hi) or below (Lo) each setpoint.
- Digital display blanking.
- Decimal point setting.
- Four-level brightness control of the bargraph and digital display.
- Bargraph center zero function.

Specifications

- Input Specs:**.....Depends on Input signal conditioner
- A/D Converter:**.....14 bit single slope
- Accuracy:**..... $\pm(0.05\%$ of reading + 2 counts)
- Temp. Coeff.:**.....100 ppm/ $^{\circ}$ C (Typical)
- Warm up time:**.....2 minutes
- Conversion Rate:**.....10 conversions per second (Typical)
- Digital Display:**.....**4 digit 0.31" LED red (std)**, green (optn)
Range -1999 to 9999 counts.
- Bargraph Display:**.....**101 segment 4" red vertical (std)**, green or tricolor (optn), horizontal (optn)
- Polarity:**.....Assumed positive. Displays - negative
- Decimal Selection:**.....Front panel button selectable, X•X•X•X•
- Positive Overrange:**..Bargraph and top segments of digital display flash.
- Negative Overrange:** First segment of bargraph and bottom segments of digital display flash.
- Relay Output:**.....Two 4 Amp Form A relays and Two 9 Amp Form C relays.
- Analog Output:**.....Isolated 16 bit user scalable mA or V
OIC (mA out).....4-20 mA @ 0 to 500 Ω max loop resistance
OIV (volts out).....0-10 V DC @ 500 Ω or higher resistance
- Power Supply:**.....AC/DC Auto sensing wide range supply
PS1 (std).....85-265 VAC / 95-300 VDC @ 3.5W
PS2.....18-48 VAC / 10-72 VDC @ 1W
- Operating Temp.:**.....0 to 50 $^{\circ}$ C
- Storage Temp.:**.....-20 $^{\circ}$ C to 70 $^{\circ}$ C
- Relative Humidity:**.....95% (non condensing)
- Case Dimensions:**.....9/64 DIN (Bezel 36Wx144Hmm)
Depth behind bezel (5.83") 148mm
Plus (0.7") 18mm for connectors
- Weight:**.....9.5 oz., 12 oz when packed

Index

Bargraph Center Point Display Mode Selection . . . 6	Decimal Point and Brightness Selection 5	Programming Conventions 2
Bargraph Color Programming Mode 9	Digital Span Selection for Display 5	Setpoint Setting & Relay Configuration Mode . . 8-9
Case Dimensions 13	Digital Span Selection for Analog Range Output . 6	Software Features 1
Component Layout 11	General Features 1	Software Logic Tree 3
Connector Pinouts 10	Lockable NEMA Splash Proof Case 13	Specifications 1
Connectors 10	Input Module Calibration Procedures 12	Two Point Analog Output Range Setting & Cal . . 7
Controls and Indicators 2	Ordering Information 14	Thermocouple and RTD Type Selection Mode . . 4
Custom Faceplates and Scales 12	Pin Descriptions 10	

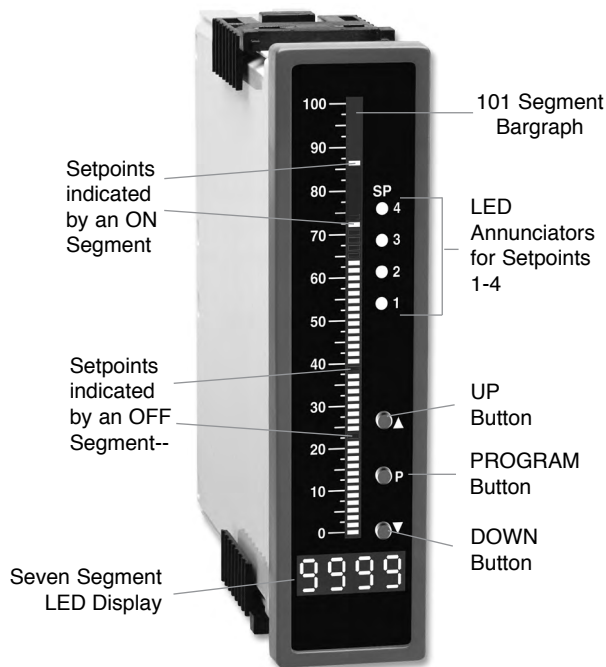

Front Panel Buttons

Program Button

The **P** button is used to move from one program step to the next. When pressed at the same time as the **↑** button, it initiates the **calibration mode**. When pressed at the same time as the **↓** button, it initiates the **setpoint setting mode**.

Programming Conventions

To explain software programming procedures, logic diagrams are used to visually assist in following the programming steps. The following symbols are used throughout the logic diagrams to represent the buttons and indicators on the meter:



This symbol represents the OPERATIONAL DISPLAY.



This is the PROGRAM button.



This is the UP button.



This is the DOWN button.

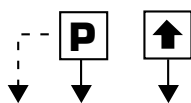

When a button is shown, press and release it to go onto the next step in the direction indicated by the arrow. When an alternative dotted line is shown, this indicates that an alternative logic branch will be followed when a particular option is present.

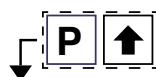

When two buttons are shown side by side and enclosed by a dotted line, they must be pressed at the same time then released to go onto the next programming step.



If an X appears through a digit, it means that any number displayed in that digit is not relevant to the function being explained.

Up Button

When in the operational display, pressing the **↑** button allows you to view the setting of the saved **Peak and Valley Values**.

When setting a displayed parameter during programming, the **↑** button is used to increase the value of the displayed parameter.

Down Button

When in the operational display, pressing the **↓** button allows you to change the **Brightness Level** as well as to view the setting of the setpoints **SP1, SP2, SP3 & SP4**.

When setting a displayed parameter during programming, the **↓** button is used to decrease the value of the displayed parameter.

Front Panel LED Display

Annunciator LEDs

The annunciator LEDs indicate the alarm status. They are labeled from bottom to top: SP1, SP2, SP3, SP4.

Digital LED Displays

The digital LED displays are used to display the meter input signal readings. They also display the programming settings during programming.

Setpoint Indication

The position of setpoints on the bargraph display are indicated by an ON or OFF segment dependent on the bargraph display being above or below the setpoint.

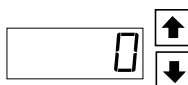

When the **↑** and **↓** buttons are shown together, the display value can be increased by pressing and releasing the **↑** button or decreased by pressing and releasing the **↓** button.

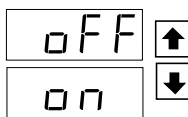

When the **↑** and **↓** buttons are shown with two displays, either display can be selected by pressing and releasing the **↑** or **↓** buttons.

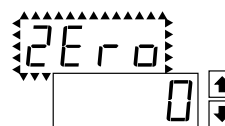

When two displays are shown together with bursts, this indicates that the display is toggling (flashing) between the name of the function and the value.

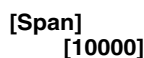

Text or numbers shown between square brackets in a procedure indicate the programming code name of the function or the value displayed on the meter display.

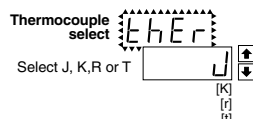

When there are more than two display selections they are shown in brackets below the first display and are also selectable by pressing and releasing the **↑** or **↓** buttons.

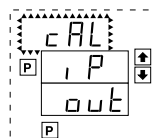

A dotted line enclosing an entire logic diagram indicates that programming branch will appear only when a particular option is present.

Software Logic Tree

The FL-B101D40-TC/RTD is an intelligent bargraph meter with a hierarchical software structure designed for easy programming and operation, as shown below in the software logic tree.

Software Version is Displayed on Power-up

When power is applied, all segments of the bargraph and digital display light up for 3 seconds. The version number of the installed software is then displayed for 2 seconds, after which, the operational display indicates the input signal.

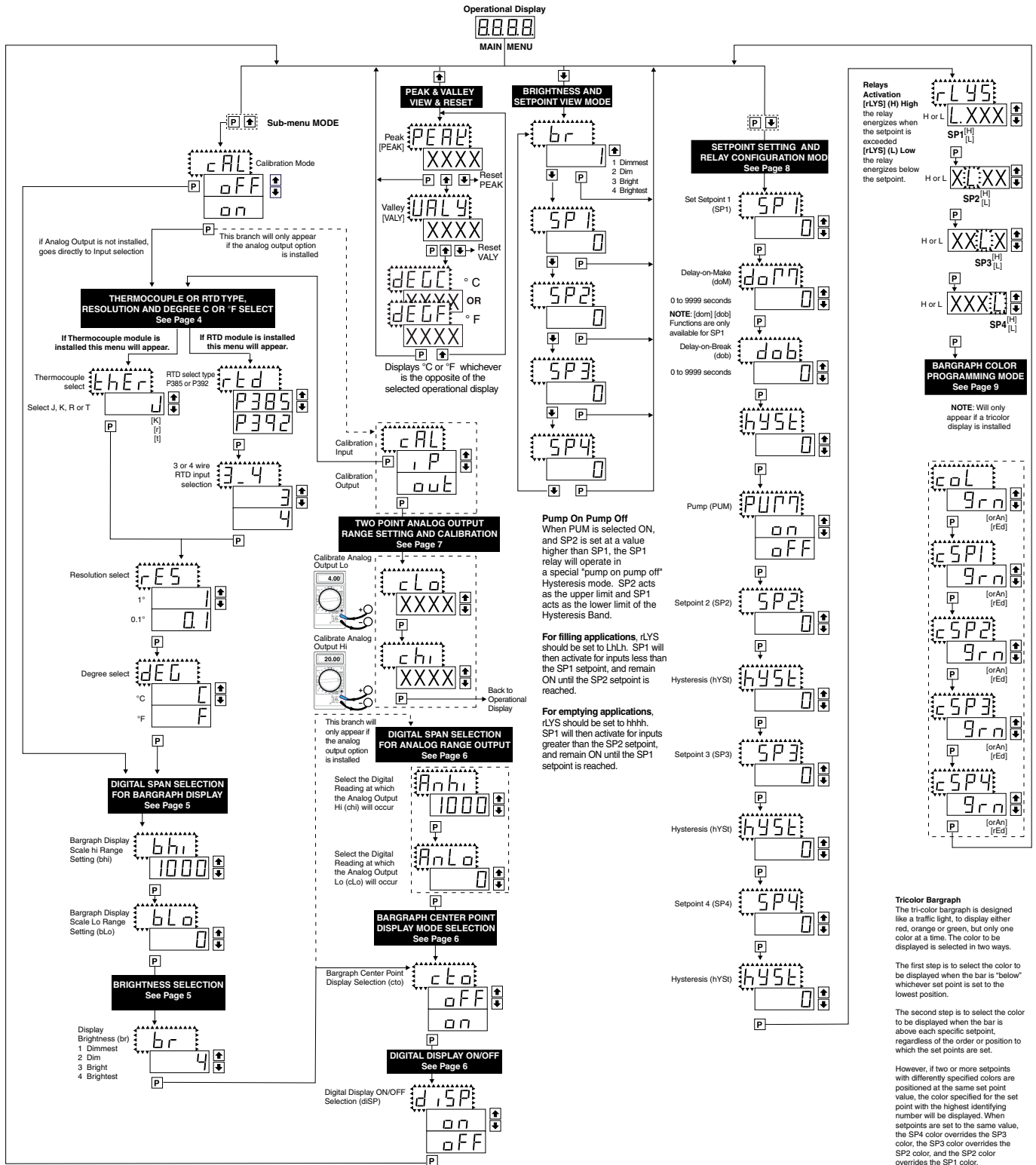

15 Second Program Timeout

Except for ZERO and SPAN settings in the Two Point Digital Calibration Mode and the Analog Output Range Setting and Calibration Mode (cLo and ch), the meter has a 15 second program timeout. If no buttons are pressed for 15 seconds in any of the other programming sequences, the meter will exit the programming mode and return to the operational display. Any program changes that were made prior to pressing the [P] button in the preceding step will not be saved.

Calibration Procedure

STEP A Enter the Calibration Mode

- 1) Press the **[P]** and **[↑]** buttons at the same time. Display toggles between [CAL] and [oFF].
- 2) Press the **[↑]** or **[↓]** button. Display changes from [oFF] to [on].
- 3) Press the **[P]** button.

STEP B If the Display toggles between [CAL] and [out] the optional Analog Output hardware is installed. In which case select [CAL] [out]. Display toggles between [thEr] or [rtd] depending on whether a IT10 Thermocouple Input Module or a IT11 RTD Input Module are detected by the soft ware. If no optional output hardware is installed the menu will skip directly to STEP C.

Thermocouple type or RTD type selection mode

STEP C Sensor Type Selection

- 1) Using the **[↑]** and **[↓]** buttons, adjust the display to the desired sensor type.
- 2) Press the **[P]** button. Display toggles between [rES] resolution select and previous [rES] setting.

STEP D Set the Resolution

- 1) Using the **[↑]** and **[↓]** buttons, adjust the display to the desired resolution [rES] value.
- 2) Press the **[P]** button. Display toggles between [dEG] and previous [dEG] selection.

STEP E Selection of Degree C or Degree F

- 1) Using the **[↑]** and **[↓]** buttons, adjust the display to either °C or °F.
- 2) Press the **[P]** button.

Sensor Range Table

Input Sensor	Resolution	°C Range	°F Range
J T/C	1°	-120 to 760°C	-200 to 1400°F
	0.1°	-120.0 to 530.0°C	-199.9 to 999.9°F
K T/C	1°	-120 to 1370°C	-200 to 2500°F
	0.1°	-120.0 to 530.0°C	-199.9 to 999.9°F
R T/C	1°	0 to 1760°C	32 to 3210°F
	0.1°	0 to 530.0°C	32.0 to 999.9°F
T T/C	1°	-120 to 400°C	-200 to 750°F
	0.1°	-120.0 to 400.0°C	-199.9 to 750.0°F
100Ω RTD (385 curve)	1°	-200 to 800°C	-200 to 1470°F
	0.1°	-199.9 to 530.0°C	-199.9 to 999.9°F
100Ω RTD (392 curve)	1°	-200 to 800°C	-200 to 1470°F
	0.1°	-199.9 to 530.0°C	-199.9 to 999.9°F

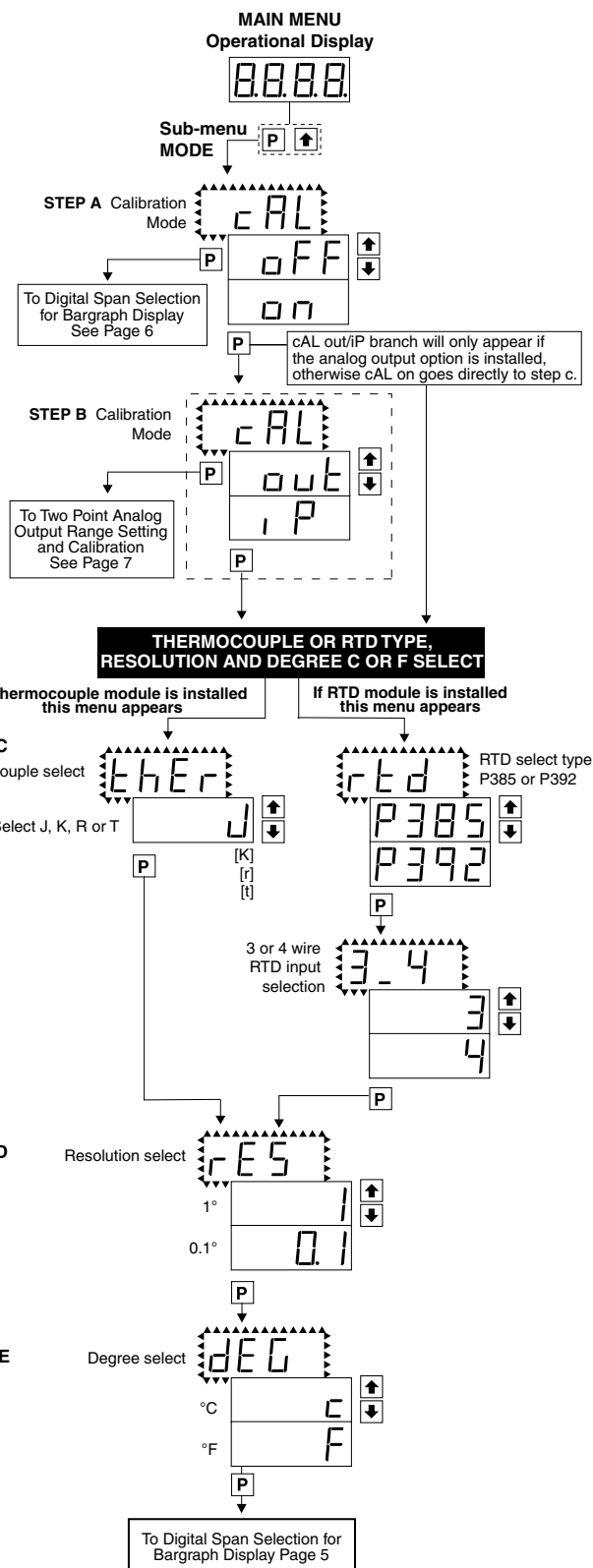

Input Module Calibration Procedure

See page 12 for the Calibration instructions of each Input Module type.

Digital Span Selection For Bargraph Display

The bargraph can be set to display full scale (0-101 bars) any portion of the digital reading from a minimum of 100 counts to a maximum of 12,000 counts. This provides higher resolution bargraph indication for those applications where the normal operating input signal range is less than the desired full scale display range of the digital display.

For Example:

If the full scale range of the meter has been set from -1999 to 9999 (0-12,000 counts), but the normal operating range of the input signal is between 4000 & 6000. The bargraph high parameter [bhi] can be set to 6000 and the bargraph low parameter [bLo] can be set to 4000.

This means that although the meter could digitally display a signal from -1999 to 9999 (0-12,000 counts), the bargraph display only begins to function at a reading of 4000, and reaches full scale indication at a reading of 6000. Although the digital display will continue reading up to 9999 before indicating overrange, the bargraph display will indicate its overrange by flashing for readings above 6000.

Example of Setting the Digital Span of the Bargraph Display to be Different than the Digital Display Range

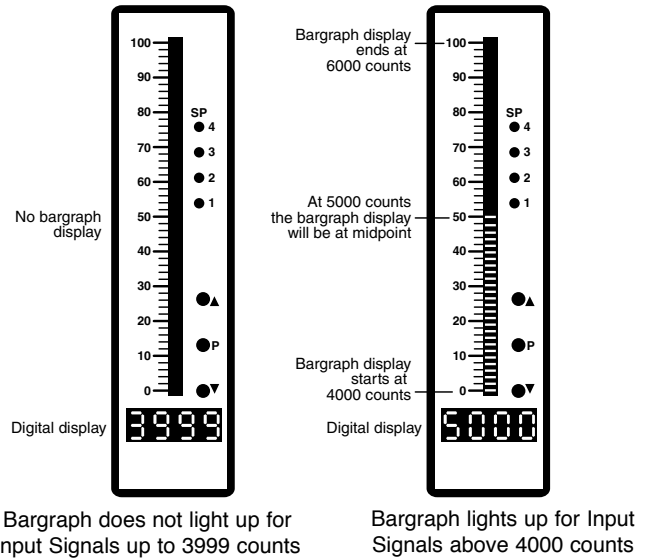

STEP A Enter the Calibration Sub Menu Mode

- 1) Press the **[P]** and **[↑]** buttons at the same time. Display toggles between [CAL] and [oFF].
- 2) Press the **[P]** button. Display toggles between [bhi] and the previous setting.

STEP B Set the Digital Span of the Bargraph Display (See example above)

- 1) Using the **[↑]** and **[↓]** buttons, adjust the display to the desired high parameter reading, e.g. 6000 counts.
- 2) Press the **[P]** button. Display toggles between [bLo] and the previous setting.
- 3) Using the **[↑]** and **[↓]** buttons, adjust the display to the desired low parameter reading, e.g. 4000 counts.
- 4) Press the **[P]** button. Display changes from [4000] to [dP].

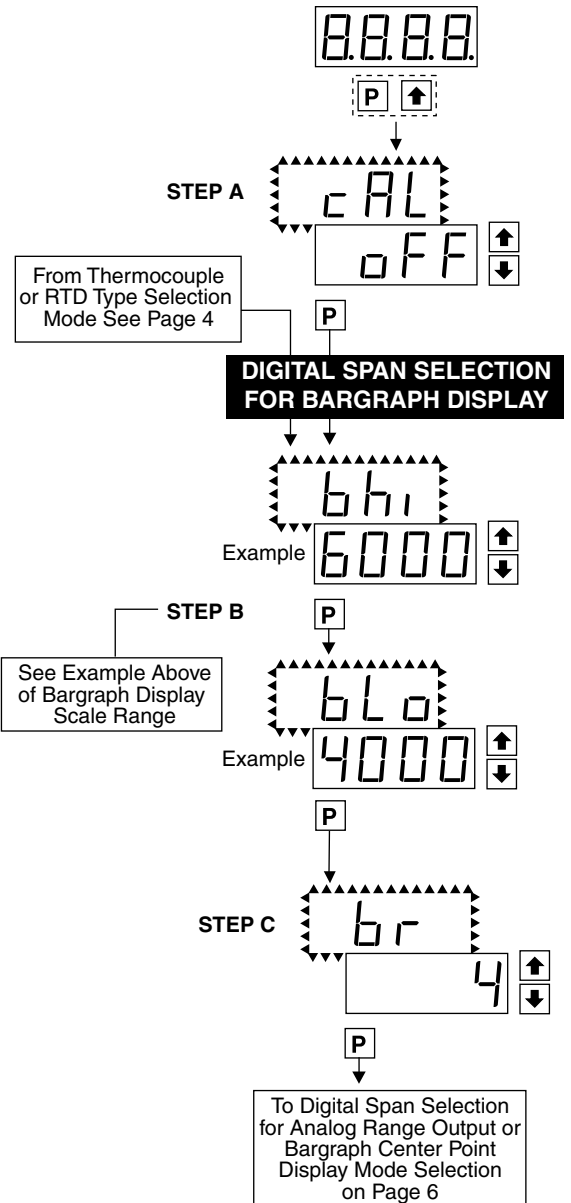

Brightness Selection

STEP C Press the **[P]** button. Display toggles between [br] and the previous brightness setting.

Set the Bargraph and Digital Display Brightness

- 1) Using the **[↑]** and **[↓]** buttons, adjust the display to the desired brightness setting (4 is the brightest setting).
- 2) Press the **[P]** button. Display toggles between [Anhi] and the previous [Anhi] setting.

Note: If at this point, the display skips directly to STEP G and toggles between [Cto] and [oFF], the software is detecting that the optional analog output hardware is NOT installed.

Digital Span Selection for Analog Range Output

STEP D Selecting the [AnHi] Digital Value for Analog High Output

- Using the \uparrow and \downarrow buttons, adjust the display to the desired digital value at which the [chi] Calibrated Analog High output will occur. For digital readings outside the digital span selected, the analog output will linearly rise above the value set for chi, up to the maximum analog output capability. However, the analog output will not go lower than the calibrated value set for cLo (see below).
- Press the P button. Display toggles between [AnLo] and previous [AnLo] setting.

STEP E Selecting the [AnLo] Digital Value for Analog Low Output

- Using the \uparrow and \downarrow buttons, adjust the display to the desired digital value at which the [cLo] Calibrated Analog Low output will occur. For Digital readings outside the Digital Span selected, the analog output will not go lower than the calibrated value set for cLo.
- Press the P button. The display toggles between [cto] and [oFF].

Note: Any two digital span points from -1999 to 9999 can be selected. The digital values for [AnHi] analog high and [AnLo] analog low can be reversed to provide a 20 to 4mA output. The digital span selected can be as small as two counts, when using the analog output to function as a Control or Alarm Driver. Small digital spans will cause the high resolution 16 bit D to A to increment digitally in stair case steps.

See Two Point Analog Output Range Setting and Calibration at the top of the next page.

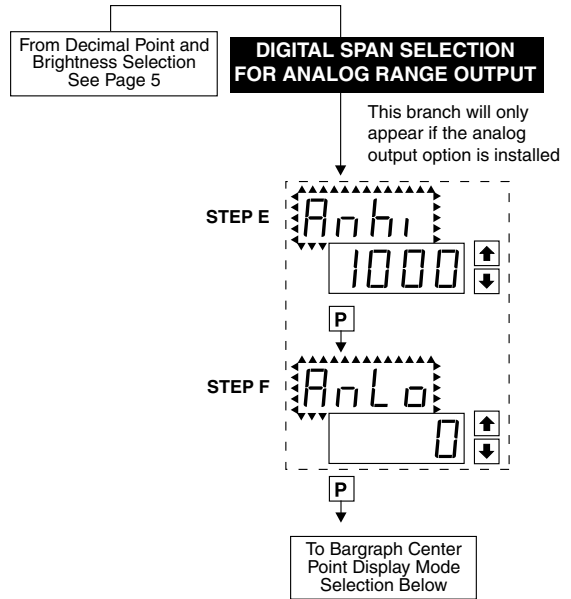

Bargraph Center Point Display Mode Selection

Example of Using the Center Point Bargraph Display Mode with a Unipolar Input

If the meter's full scale range is set to 5000 counts, the midpoint would be 2500 counts. If a signal of 2500 counts is applied only one segment at the 2500 count mark will light up. If a signal of 4000 counts is applied the segments between the center segment (2500 counts) and the 4000 count mark light up.

If a signal of 1000 counts is applied, the segments between the center segment (2500 counts) and the 1000 count mark will light up.

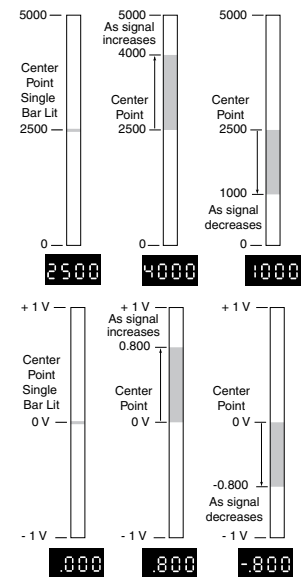

Example of Using the Center Point Bargraph Display Mode with Bipolar Signal Inputs

The meter may also be calibrated to display symmetrical bipolar signals such as ± 1 V or ± 10 V. When the center point display mode is selected, it will then function as a center zero meter. When positive signals are applied, the bar will go up from the center point, and when negative signals are applied, the bar will go down from the center point.

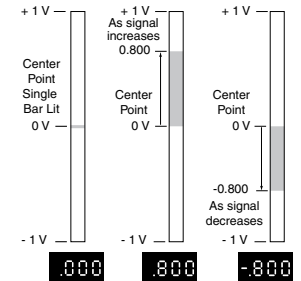

STEP F Bargraph Center Point Mode Selection (See example above)

- To select bargraph center point mode, press the \uparrow or \downarrow button. Display changes from [oFF] to [on].
- Press the P button. Display toggles between [diSP] and [on] or [oFF].

STEP G Digital Display ON/OFF Selection

- To set the display to [oFF], press the \uparrow or \downarrow button. Display toggles between [diSP] and [oFF].
- Press the P button. The display exits the calibration mode and returns to the operational display. Only the bargraph display is on and the digital display is off.

If the digital display is selected to be off, pressing any button to make programming changes or to view setpoints activates the digital display. When the procedure is complete, the digital display will then automatically switch off.

The Display/Bargraph settings are now complete.

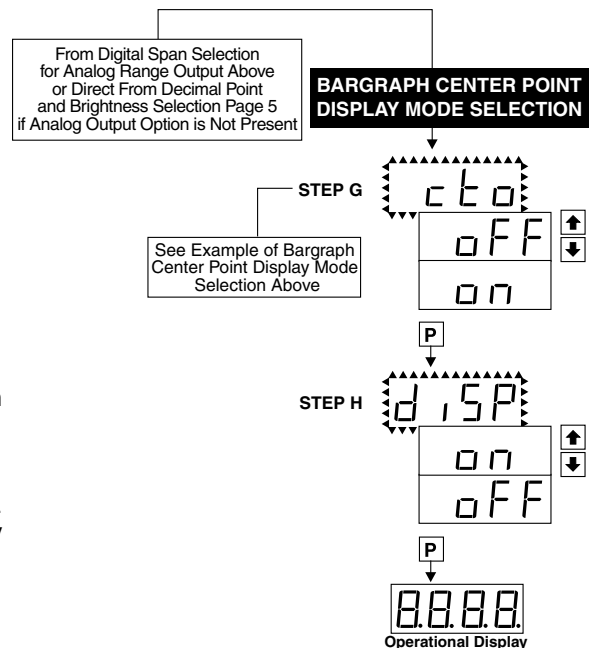

Two Point Analog Output Range Setting and Calibration

Determine if the Analog Output Selection Header is in the 4 to 20mA (0-20mA) position or the 0 to 10VDC position. If necessary, the module may have to be removed and the header position changed (see Component Layout below).

Note: Always disconnect power from the meter before removing the analog output module to adjust the mA or Volts output selection header and reinstalling it. When power is reconnected, the meter's software will automatically detect the presence or absence of the analog output module.

STEP A Enter the Calibration Mode

- 1) Press the **[P]** and **[↑]** buttons at the same time. Display toggles between [cAL] and [oFF].
- 2) Press the **[↓]** or **[↑]** button. Display changes from [oFF] to [on].
- 3) Press the **[P]** button. Display toggles between [cAL] and [out] input calibration.

Note: If at this point the display skips directly to toggle between Zero and the previous Zero setting, the software is detecting that the optional analog output hardware is NOT installed.

STEP B Enter the Two Point Analog [out] Output Range Setting and Calibration Mode

- 1) Press the **[P]** button. Display toggles between [cLo] and an internal scale factor.

STEP E Set or Calibrate [cLo] the Low Analog Value of the Analog Output Range

- 1) Connect a multimeter to analog output pins 17 and 18 (see Rear Panel Pinouts on page 10). Using the **[↑]** and **[↓]** buttons, adjust the analog output to the desired low value as measured on the multimeter. cLo may be adjusted to any value from -0.3 mA to 18 mA (mA output selected) or from -0.6 V to 8 V (volt output selected). However, the output of cLo must always be less than the value selected for chi. If a reversed analog output is desired, the values selected to establish the Digital Span can be reversed (see top of page 6). For digital readings outside the Digital Span selected, the analog output will not go any lower than the calibrated value set for cLo. However, the analog output will linearly rise above the value set for chi, up to the maximum analog output capability (see chi below).
- 2) Press the **[P]** button. Display toggles between [chi] and an internal scale factor.

STEP F Set or Calibrate [chi] the High Analog Value of the Analog Output Range

- 1) Using the **[↑]** and **[↓]** buttons, adjust the analog output to the desired high value as measured on the multimeter display. chi may be adjusted to any value from 18 mA to 24 mA (mA output) or from 8 V to 10.3 V (volt output). However, the value must be higher than the value selected for cLo. For digital readings outside the Digital Span selected, the analog output will linearly rise above the value set for chi, up to the maximum analog output capability.
- 2) Press the **[P]** button. The meter exits the calibration mode and returns to the operational display.

Note: The analog output range established by the values selected for cLo and chi will occur, automatically scaled, between the two digital values selected for AnHi and AnLo. However, the analog output can linearly rise above the chi value set for digital readings outside the digital span selected. See Digital Span Selection on page 6.

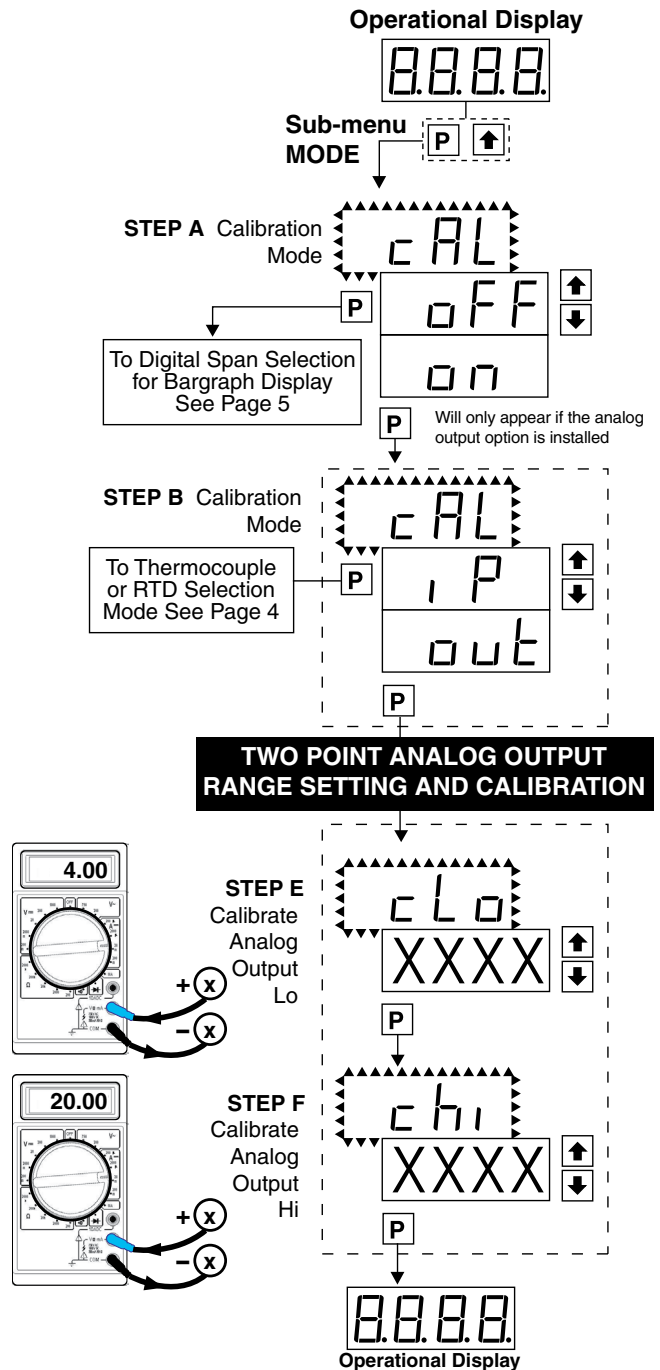

Setpoint Setting and Relay Configuration Mode

The following programming steps are required to enter the setpoint values and configure the relay functions in a meter with four relays using four setpoints. Generally if less than four relays are installed, the setpoints without relays are operational in software for tri-color control or display only purposes. To remove unwanted setpoint indications, set them to 9999 or -1999 depending on the relay activation mode selected.

STEP A Enter the Setpoint Mode

- 1) Press the **[P]** and **[↓]** buttons at the same time. Display toggles between [SP1] and the previous SP1 setting.

STEP B Set Setpoint 1 [SP1]

- 1) Using the **[↑]** and **[↓]** buttons, adjust the display to the desired SP1 value.
- 2) Press the **[P]** button. Display toggles between [doM] and the previous [doM] setting.

STEP C Set the SP1 Delay-on-Make [doM] Delay Time Setting

- 1) Using the **[↑]** and **[↓]** buttons, adjust the display to the desired [doM] value (0 to 9999 seconds). The reading must continuously remain in an alarm condition until this delay time has elapsed before the relay will make contact (energize).
- 2) Press the **[P]** button. Display toggles between [dob] and the previous [dob] setting.

STEP D Set the SP1 Delay-on-Break [dob] Delay Time Setting

- 1) Using the **[↑]** and **[↓]** buttons, adjust the display to the desired [dob] value (0 to 9999 seconds). The reading must continuously remain in a non-alarm condition until this delay time has elapsed before the relay will break contact (de-energize).
- 2) Press the **[P]** button. Display toggles between [hYSt] and the previous [hYSt] setting.

STEP E Select the Hysteresis [hYSt]

- 1) Using the **[↑]** and **[↓]** buttons, select the Hysteresis to be ON or OFF.
- 2) Press the **[P]** button. Display toggles between PUM and (on) or (oFF).

STEP F Select Pump [PUM] (on) or (oFF)

- 1) Using the **[↑]** and **[↓]** buttons, select the Pump to be ON or OFF. When PUM is selected ON, and SP2 is set at a value higher than SP1, the SP1 relay will operate in a special "pump on pump off" mode. SP2 acts as the upper limit and SP1 acts as the lower limit of the Hysteresis Band on the SP1 relay.

For filling applications:

[rLYS] should be set to [LhXX] (see step M). The SP1 relay and SP1 LED Annunciator will then activate for inputs less than the SP1 setpoint, and remain ON until the SP2 setpoint is reached.

For emptying applications:

[rLYS] should be set to [hhXX] (see step M). The SP1 relay and SP1 LED Annunciator will then activate for inputs greater than the SP2 setpoint, and remain ON until the SP1 setpoint is reached.

- 2) Press the **[P]** button. Display toggles between [SP2] and the previous SP2 setting.

STEP G Set Setpoint 2 (SP2)

- 1) Using the **[↑]** and **[↓]** buttons, adjust the display to the desired SP2 value.
- 2) Press the **[P]** button. Display toggles between [hySt] and the previous [hySt] setting.

STEP H Select the Hysteresis [hYSt]

- 1) Using the **[↑]** and **[↓]** buttons, select the Hysteresis to be ON or OFF.
- 2) Press the **[P]** button. Display toggles between [SP3] and the previous [SP3] setting.

STEP I Set Setpoint 3 (SP3) (No [doM] or [dob])

- 1) Using the **[↑]** and **[↓]** buttons, adjust the display to the desired SP3 value.
- 2) Press the **[P]** button. Display toggles between [hySt] and the previous [hySt] setting.

STEP J Select the Hysteresis [hYSt]

- 1) Using the **[↑]** and **[↓]** buttons, select the Hysteresis to be ON or OFF.
- 2) Press the **[P]** button. Display toggles between [SP4] and the previous [SP4] setting.

STEP K Set Setpoint 4 (SP4) (No [doM] or [dob])

- 1) Using the **[↑]** and **[↓]** buttons, adjust the display to the desired SP4 value.
- 2) Press the **[P]** button. Display toggles between [hySt] and the previous [hySt] setting.

STEP L Select the Hysteresis [hYSt]

- 1) Using the **[↑]** and **[↓]** buttons, select the Hysteresis to be ON or OFF.
- 2) Press the **[P]** button. Display toggles between [rLYS] and the previous relay setting.

Please Continue On Next Page.

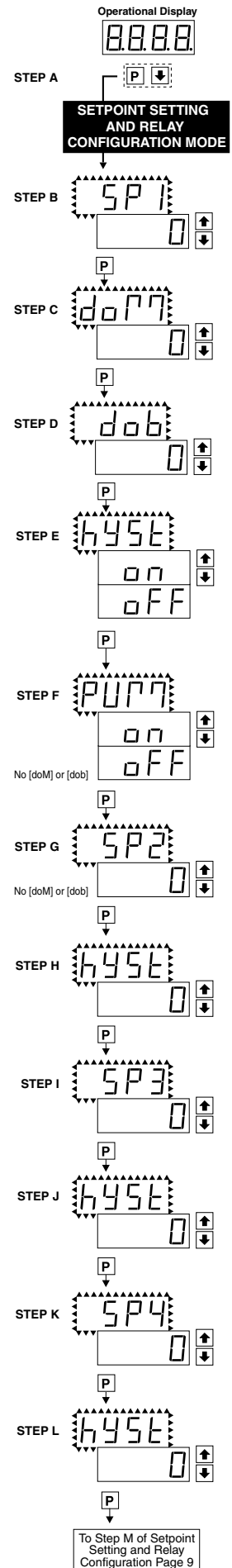

Setpoint Setting and Relay Configuration Mode Continued

STEP M Set Relay Activation mode [rLYS] for SP1

(H) High the relay energizes when the setpoint is exceeded. (L) Low the relay energizes below the setpoint. The setpoint is indicated from left to right SP1, SP2, SP3, SP4.

- Using the and buttons, select (L) or (H) for the first digit, which corresponds to SP1.
- Press the button. The SP2 Relay Activation digit begins to flash, and its decimal point is lit.

STEP N Set High (H) or Low (L) for SP2

- Using the and buttons, select (L) or (H) for the second digit, which corresponds to SP2.
- Press the button. The SP3 Relay Activation digit begins to flash, and its decimal point is lit.

STEP O Set High (H) or Low (L) for SP3

- Using the and buttons, select (L) or (H) for the third digit, which corresponds to SP3.
- Press the button. The SP4 Relay Activation digit begins to flash, and its decimal point is lit.

STEP P Set High (H) or Low (L) for SP4

- Using the and buttons, select (L) or (H) for the fourth digit, which corresponds to SP4.
- Press the button.

If a mono-color red or green display is installed then the Setpoint Relay Programming Mode is now complete and the meter returns to the operational display.

If a tricolor bargraph display is installed then the Bargraph Color Programming Mode will be entered and display toggles between [CoL] and the previous setting. Color selection menu will be displayed.

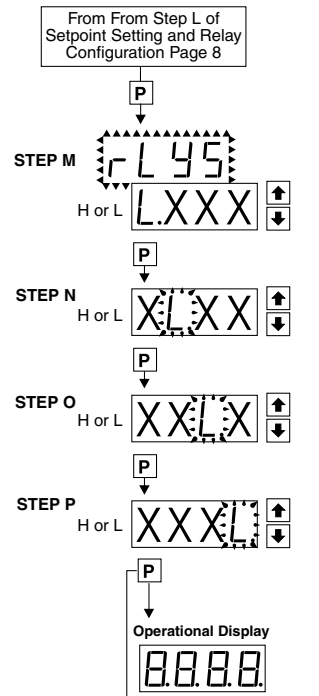

Bargraph Color Programming Mode

To comply with the latest safety requirements, the tri-color bargraph is designed like a traffic light, to display either red, orange or green, but only one color at a time. When the bar reaches a selected color change point, the entire bar will change to the color designated for that zone. This eliminates any ambiguity as to the signal status, especially just after transitioning to a new zone.

First (Step Q) is to select the color to be displayed, when the bar is “below*”, whichever set point is set to the lowest position.

Second (Steps R, S, T, and U) is to select the color to be displayed when the bar is above each specific set point, regardless of the order or position to which the set points are set.

However, if two or more setpoints with differently specified colors are positioned at the same set point value, the color specified for the set point with the highest identifying number will be displayed. When set points are set to the same value, the SP4 color overrides the SP3 color, the SP3 color overrides the SP2 color, and the SP2 color overrides the SP1 color.

STEP Q Select Bargraph Color when the bar is BELOW* the Setpoint that is set to the lowest position

- Using the and buttons, select the desired bargraph color [grn], [oran] or [red]
- Press the button. Display toggles between [CSP1] and the previous color setting.

STEP R Select Bargraph Color when the bar is ABOVE* SP1 Setpoint

- Using the and buttons, select the desired bargraph color [grn], [oran] or [red]
- Press the button. Display toggles between [CSP2] and the previous color setting.

STEP S Select Bargraph Color when the bar is ABOVE* SP2 Setpoint

- Using the and buttons, select the desired bargraph color [grn], [oran] or [red]
- Press the button. Display toggles between [CSP3] and the previous color setting.

STEP T Select Bargraph Color when the bar is ABOVE* SP3 Setpoint

- Using the and buttons, select the desired bargraph color [grn], [oran] or [red]
- Press the button. Display toggles between [CSP4] and the previous color setting.

STEP U Select Bargraph Color when the bar is ABOVE* SP4 Setpoint

- Using the and buttons, select the desired bargraph color [grn], [oran] or [red]
- Press the button. The meter exits the setpoint mode and returns to the operational display.

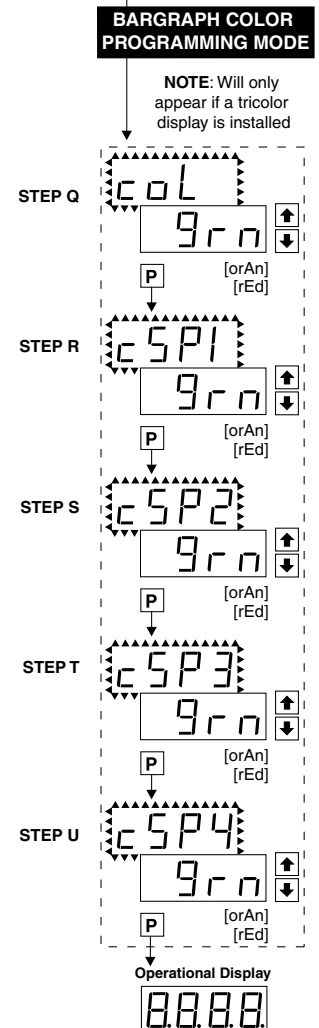

The Bargraph Color programming mode is now complete.



Note: For horizontal display formats BELOW should be read as, “to the left” and ABOVE* should be read as, “to the right”.

Connector Pinouts

This meter uses plug-in type screw terminal connectors for all input and output connections. The power supply connections (pins 23 and 24) have a unique plug and socket outline to prevent cross connection. The main board uses standard right-angled connectors.

Replacement 2-, 3-, and 4-pin plug connectors are available (see Accessories on page 20).



WARNING: AC and DC input signals and power supply voltages can be hazardous. Do Not connect live wires to screw terminal plugs, and do not insert, remove or handle screw terminal plugs with live wires connected.

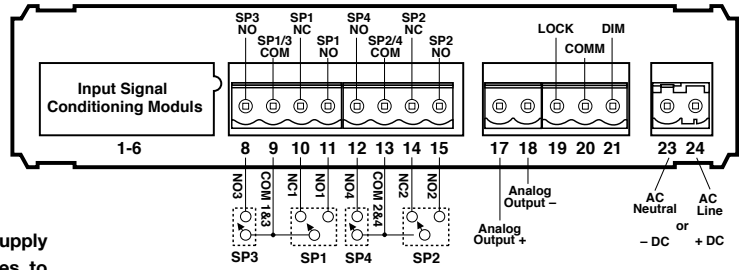

Note: The sequence of setpoint outputs is now 3-1-4-2, enabling delay on make (dom) and delay on break (dob) to be used with both Form "C" relays.

Pin Descriptions

Pins 1 to 6 – Input Signal

Pins 1 to 6 are reserved for the input signal conditioner. See the data sheet for the selected input signal conditioner.

Pins 8 to 15 – Relay Output Pins

- Pin 8** SP3 NO. Normally Open 4 Amp Form A.
- Pin 9** SP1/3 COM. Common for SP1 and SP3.
- Pin 10** SP1 NC. Normally Closed 9 Amp Form C.
- Pin 11** SP1 NO. Normally Open 9 Amp Form C.
- Pin 12** SP4 NO. Normally Open 4 Amp Form A.
- Pin 13** SP2/4 COM. Common for SP2 and SP4.
- Pin 14** SP2 NC. Normally Closed 9 Amp Form C.
- Pin 15** SP2 NO. Normally Open 9 Amp Form C.

Pins 17 to 21 – Rear Panel Switches

- Pin 17** ANALOG OUTPUT (+). mA (0 to 20 mA/4 to 20 mA) or V (0 to 10 V) output is header selectable.
- Pin 18** ANALOG OUTPUT (-). mA (0 to 20 mA/4 to 20 mA) or V (0 to 10 V) output is header selectable.
- Pin 19** Programming LOCK. By connecting the LOCK pin to the COMMON pin, the meter's programmed parameters can be viewed but not changed.
- Pin 20** COMMON. To activate the LOCK or DIM functions from the rear of the meter, the respective pins have to be connected to the COMMON pin. This pin is connected to the internal power supply ground.
- Pin 21** DIM. By connecting the display dim (DIM) pin to the COMMON pin, the display brightness setting is halved.

Pins 23 and 24 – AC/DC Power Input

Auto-sensing AC/DC power supply. For voltages between 85-265 V AC / 95-300 V DC (PS1) or 18-48 V AC / 10-72 V DC (PS2).

- Pin 23** AC Neutral / -DC. Neutral power supply line.
- Pin 24** AC line / +DC. Live power supply line.

Connectors



WARNING

AC and DC input signals and power supply voltages can be hazardous. Do Not connect live wires to terminal blocks, and do not insert, remove or handle terminal blocks with live wires connected.

Standard plug-in screw terminal blocks provided by Texmate:

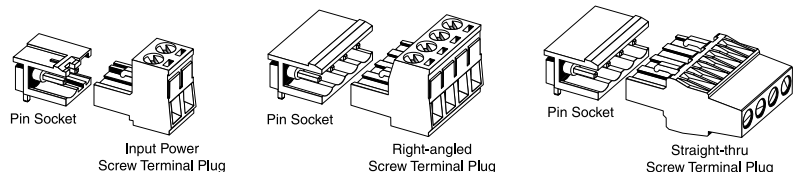

Component Layout

MAIN BOARD

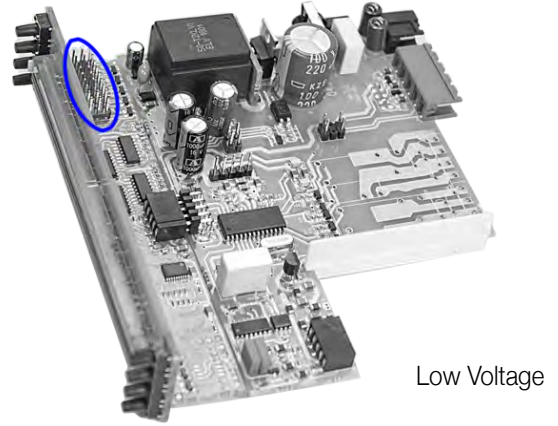
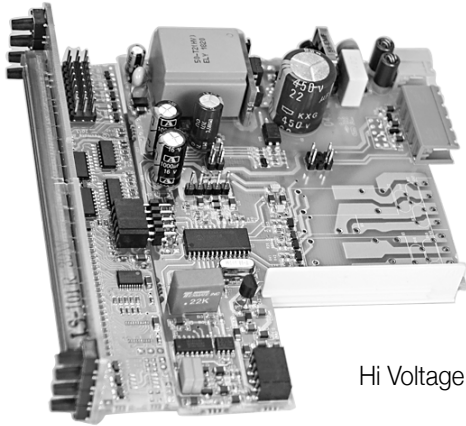

Thermocouple

IT10 Thermocouple, J/K/R/T Selectable C/F, 1/0.1

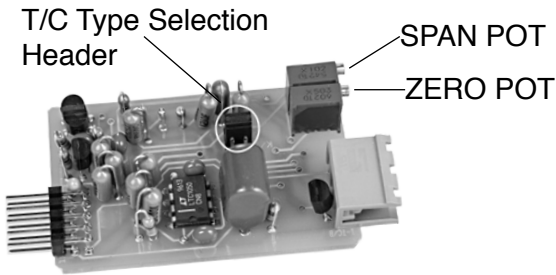

RTD

IT11 RTD, 100Ω Pt. Selectable 3/4-wire, °C/°F, 1°/0.1°, 385/392

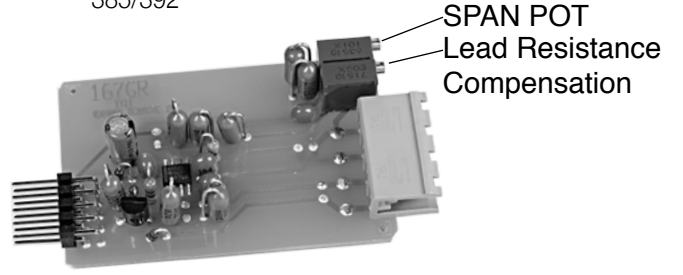

IT10: Thermocouple, J/K/R/T, Selectable C/ F, 1 /0.1

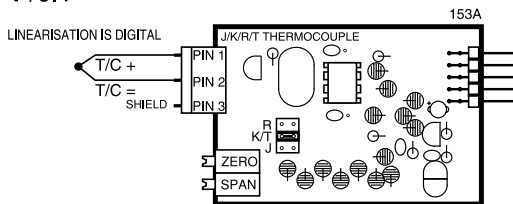

IT11: RTD, 100 Pt. Select 3/4-wire, C/F, 1/0.1

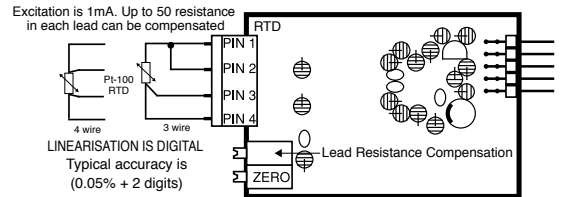

Input Module Calibration Procedure

IT10 Thermocouple Input Signal Conditioner installed.

1. The cold junction select header must be installed in the correct position for the thermocouple type to be used. Thermocouple types J, K, R and T are supported. If you wish to use a different thermocouple from the default setting of K/T it is necessary to remove the module and move the cold junction select header to the appropriate position.
2. Unplug the connector plugs from the meter. Remove the case back panel and slide the module out of the case.
3. After selecting the appropriate header position, insert the module back into the case. Snap the back panel back into the case. Apply power to the meter.
4. Enter the program mode and select the type of thermocouple (J, K, R, T), the resolution (0.1° or 1°) and the display units (°C or °F). See Page 4 of the data sheet for details.
5. Connect a thermocouple simulator to the meter inputs. Apply an input corresponding to 0° and adjust the ZERO Potentiometer to make the display read 0.
6. Apply an input corresponding to the maximum reading of the thermocouple and adjust the SPAN Potentiometer to make the display read correctly.
7. The meter is now calibrated and ready for use. Calibration will have to be performed again if the thermocouple type is changed.

IT10: Thermocouple, J/K/R/T, Selectable °C/°F, 1°/0.1°

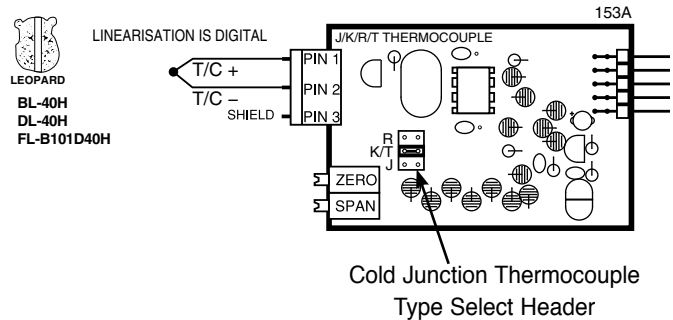

IT11 or IT15 RTD Input Signal Conditioner installed.

1. Enter the program mode and select the type of RTD (385 or 392 curve and 3-wire/ 4-wire), the resolution (0.1° or 1°) and the display units (°C or °F). See Page 4 of the data sheet for details.
2. Connect an RTD simulator to the meter inputs. Apply an input corresponding to 0° and adjust the ZERO Potentiometer to make the display read 0.
3. Introduce a lead resistance of 10Ω in each lead. Adjust the Lead Resistance Compensation potentiometer to make the display again read 0.
4. The meter is now calibrated and ready for use. Calibration will have to be performed again if the RTD type is changed.

IT11: RTD, 100Ω Pt. Select 3/4-wire, °C/°F, 1°/0.1°

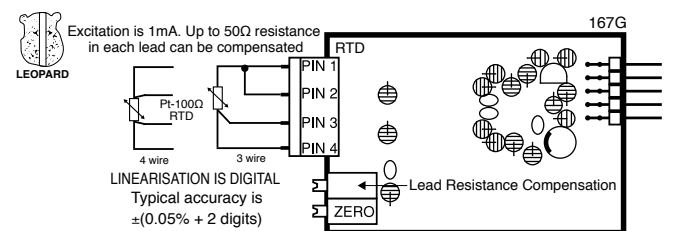

Custom Face Plates and Scales



- Custom face plates have a non-recurring artwork charge. A serial number is then assigned to each artwork, to facilitate re-ordering.

- Small Run or One-Off custom face plates incur an installation charge, and are generally printed on a special plastic film, which is then laminated to custom faceplate blanks as required.

- Large Run (300 pieces min): custom face plates are production silk screened, issued a part number.

Part Number	Description	List
Small Run Custom Face plates for Bargraphs		
ART-NRC-DES	Small run NRC custom faceplate design	
ART-NRC-LOGO	Small run NRC custom faceplate design with Co.Logo	
ART-FS1	Small run custom Faceplate - 1 color	
ART-FS2	Small run custom Faceplate - 2 color	
ART-FS3	Small run custom Faceplate - 3 color	
ART-FS4	Small run custom Faceplate - 4 color	
ART-FS5	Small run custom Faceplate - 5 color	
Specify artwork serial number when ordering face plate installation. ie: AFB-XXXXX		
Large Run Custom Face plates for Bargraphs		
ART-NRC-FILM	Large run NRC custom faceplate design & films	
ART-FPMAINT	Inventory management fee for 2 years	
ART-FL1	Large run 300pcs custom faceplate - 1 color	
ART-FL2	Large run 300pcs custom faceplate - 2 color	
ART-FL3	Large run 300pcs custom faceplate - 3 color	
ART-FL4	Large run 300pcs custom faceplate - 4 color	
ART-FL5	Large run 300pcs custom faceplate - 5 color	

When ordering Large Run Face plates to be installed specify the custom part number issued for each different artwork. ie: 77-FLXXXXX

Case Dimensions

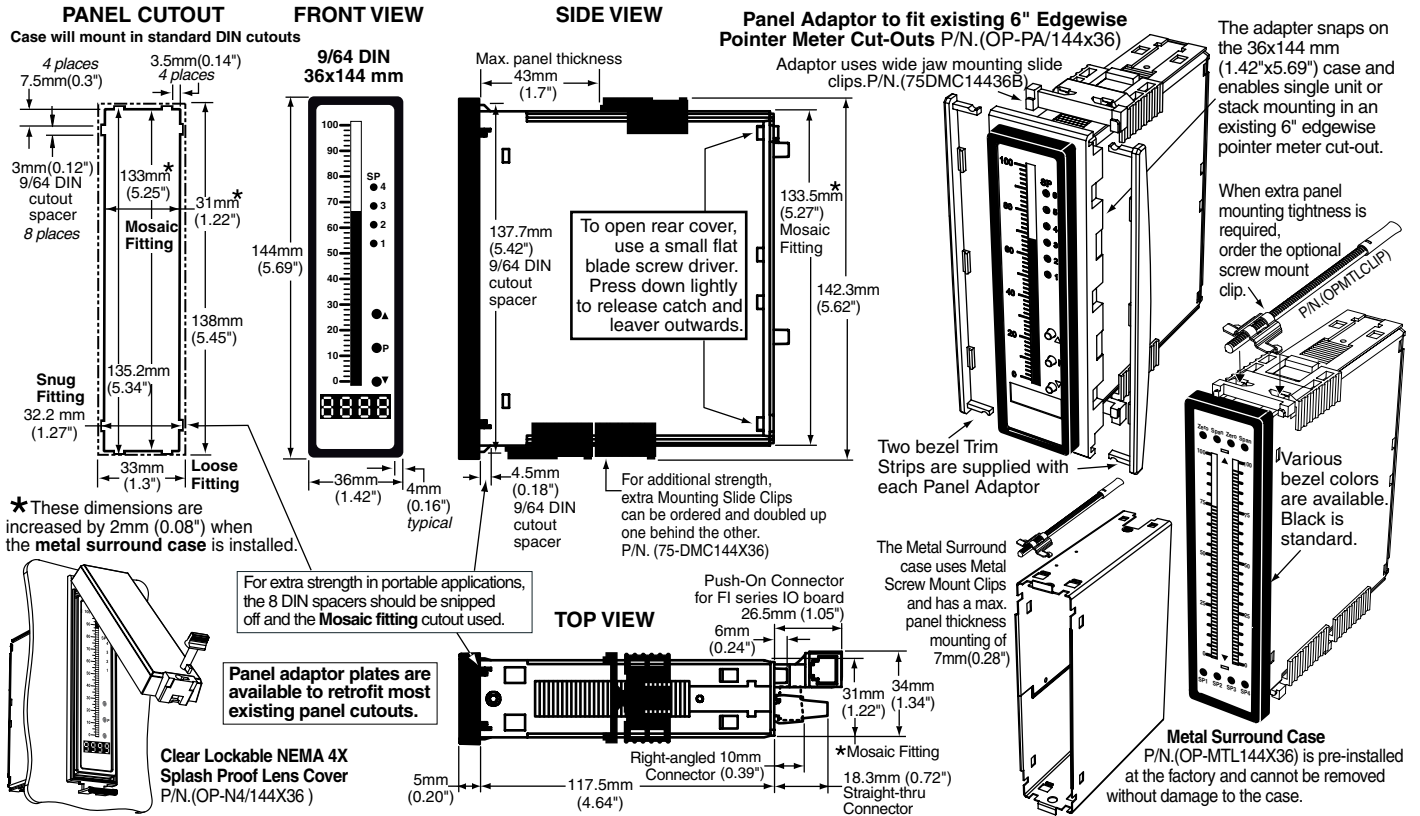

Hinged Clear Lockable Polycarbonate NEMA 4X Splash Proof Cover

This rugged, impact resistant, clear lens cover is designed to be dust and water proof to NEMA 4 and IP65 standards. The lens cover consists of a base and cover with a cam hinge and key-lock locking device.

An O-ring, or neoprene gasket forms a seal between the base and the panel. When opened, a cam hinge prevents the cover from closing until pushed closed.

The cover has a tapered recess that, when closed, forms a capillary seal with a tapered ridge on the base. A capillary seal is created when capillary action causes a small amount of water to be drawn in between the two surfaces producing a water tight film around the sealing area.

For those applications, such as food processing, where fluid residues are unacceptable, apply a light coating of clear silicone grease, or other approved sealant to the mating groove to prevent any ingress of liquid and enable the cover to withstand steam cleaning.

Turning the key-lock tightens the cover to the base, ensuring seal integrity. A safety catch keeps the cover closed even when the key is turned to the open position and removed. The keyhole can also be used to attach a safety seal clip, preventing unauthorized opening.

9/64 DIN
36x144 mm (1.42"x5.69")
P/N: OP-N4/144X36

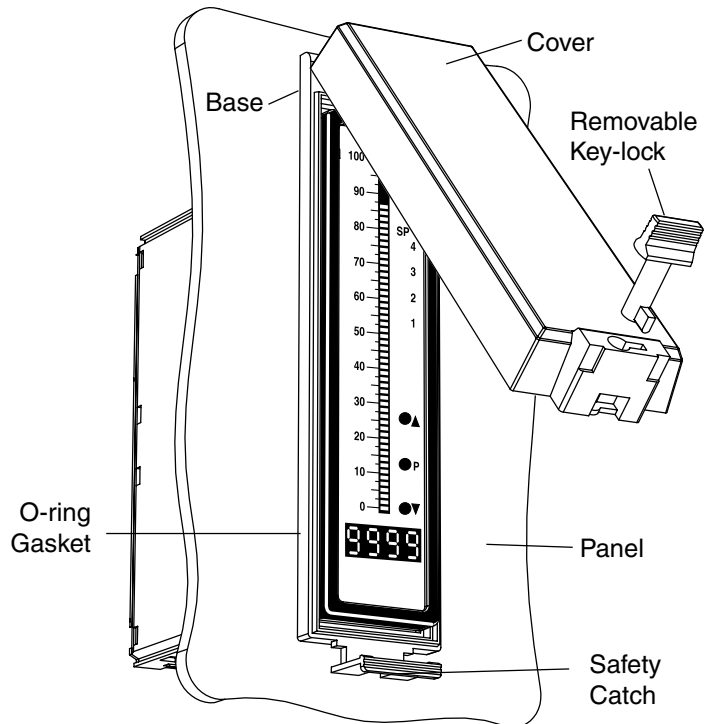

Ordering Information



Add to the basic model number the order code suffix for each standard option required. The last suffix is to indicate how many different special options and or accessories that you may require to be included with this product.

Ordering Example: FL-B101D40-TC-VRR-PS1-IT10-OIC-R11-OA2 plus ZR and an OP-N4/144X36,

► BASIC MODEL NUMBER

FL-B101D40-TC 144x36mm, 101 Segment Bargraph, 4 Digit, Thermocouple.....
 FL-B101D40-RTD 144x36mm, 101 Segment Bargraph, 4 Digit, RTD

Standard Options for this Model Number

Order Code Suffix	Description	List
► DISPLAY		
VRR	Red LED Bargraph w/4 Digit Red DPM, Vertical	
VGG	Green LED Bargraph w/4 Digit Green DPM, Vertical	
VGR	Green LED Bargraph w/4 Digit Red DPM, Vertical	
VVG	Red LED Bargraph w/4 Digit Green DPM, Vertical	
VTG	Tri-Color Bargraph w/4 Digit Green DPM, Vertical	
VTR	Tri-Color Bargraph w/4 Digit Red DPM, Vertical	
HRR	Red LED Bargraph w/4 Digit Red DPM, Horizontal	
HGG	Green LED Bargraph w/4 Digit Green DPM, Horizontal	
HGR	Green LED Bargraph w/4 Digit Red DPM, Horizontal	
HRG	Red LED Bargraph w/4 Digit Green DPM, Horizontal	
HTG	Tri-Color Bargraph w/4 Digit Green DPM, Horizontal	
HTR	Tri-Color Bargraph w/4 Digit Red DPM, Horizontal	
DSGG	Dual Scale Green LED Vertical Bargraph w/4 Digit Green DPM	
DSGR	Dual Scale Green LED Vertical Bargraph w/4 Digit Red DPM	
DSRG	Dual Scale Red LED Vertical Bargraph w/4 Digit Green DPM	
DSRR	Dual Scale Red LED Vertical Bargraph w/4 Digit Red DPM	
DSTG	Dual Scale Tri-Color Vertical Bargraph w/4 Digit Green DPM	
DSTR	Dual Scale Tri-Color Vertical Bargraph w/4 Digit Red DPM	

► POWER SUPPLY

PS185-265VAC/95-300VDC
 PS218-48VAC/10-72VDC

► INPUT MODULES

Unless otherwise specified Texmate will ship all modules precalibrated with factory preselected ranges and/or scalings as shown in **BOLD** type.

IT10 . . .Thermocouple, J/K/R/T, Selectable °C/°F, **1°/0.1°**
 IT11 . . .RTD, 100Ω Pt. Selectable 3/4-wire, °C/°F, **1°/0.1°**, 385/392.

► ANALOG OUTPUT

OICIsolated 16 Bit Current Output, 4-20mA
 OIVIsolated 16 Bit Voltage Output, 0-10VDC

► RELAY OUTPUT

R1Single 4A Form A Relay
 R2Dual 4A Form A Relays
 R11Single 9A Form C Relay
 R12Dual 9A Form C Relays
 R13Dual 9A Form C & One 4A Form A Relays
 R14Dual 9A Form C & Dual 4A Form A Relays
 R15Single 9A Form C & Dual 4A Form A Relays
 R16Single 9A Form C & Single 4A Form A Relays

Special Options and Accessories

Part Number	Description	List
► SPECIAL OPTIONS (Specify Inputs or Outputs & Req. Reading)		
ZR	Calibrated Range Change to another Standard Range	
ZS	Custom display scaling within standard ranges	
ZS-AO	Custom scaling of analog output	
► ACCESSORIES (Specify Serial # for Custom Artwork Installation)		
75-DMC14436B	Side Slide Brackets-Wide opening (2 pc)	
75-DMC144X36	Side Slide Brackets-stand. (2 pc) - extra set	
93-PLUG2P-DR	Extra Screw Terminal Conn., 2 Pin Power Plug	
93-PLUG2P-DR	Extra Screw Terminal Conn., 2 Pin Plug	
93-PLUG3P-DR	Extra Screw Terminal Conn., 3 Pin Plug	
93-PLUG4P-DR	Extra Screw Terminal Conn., 4 Pin Plug	
93-PLUG5P-DR	Extra Screw Terminal Conn., 5 Pin Plug	
OP-MTL144x36	Metal Surround Case, includes screw mounting clips	
OP-MTLCLIP	Screw Mounting Clips (2 pc) - to screw tighten slide brackets	
OP-N4/144X36	144x36mm clear lockable front cover-NEMA 4X, splash proof	
OP-PA/144X36	Panel Adapter for 144x36mm from 6 inch cutout	

For Custom Face Plates see page 14.

Many other options and accessories are available. See full price list for more details.

WARRANTY

Texmate warrants that its products are free from defects in material and workmanship under normal use and service for a period of one year from date of shipment. Texmate's obligations under this warranty are limited to replacement or repair, at its option, at its factory, of any of the products which shall, within the applicable period after shipment, be returned to Texmate's facility, transportation charges pre-paid, and which are, after examination, disclosed to the satisfaction of Texmate to be thus defective. The warranty shall not apply to any equipment which shall have been repaired or altered, except by Texmate, or which shall have been subjected to misuse, negligence, or accident. In no case shall Texmate's liability exceed the original purchase price. The aforementioned provisions do not extend the original warranty period of any product which has been either repaired or replaced by Texmate.

USER'S RESPONSIBILITY

We are pleased to offer suggestions on the use of our various products either by way of printed matter or through direct contact with our sales/application engineering staff. However, since we have no control over the use of our products once they are shipped, **NO WARRANTY WHETHER OF MERCHANTABILITY, FITNESS FOR PURPOSE, OR OTHERWISE** is made beyond the repair, replacement, or refund of purchase price at the sole discretion of Texmate. Users shall determine the suitability of the proDXct for the intended application before using, and the users assume all risk and liability whatsoever in connection therewith, regardless of any of our suggestions or statements as to application or construction. In no event shall Texmate's liability, in law or otherwise, be in excess of the purchase price of the product.

Texmate cannot assume responsibility for any circuitry described. No circuit patent or software licenses are implied. Texmate reserves the right to change circuitry, operating software, specifications, and prices without notice at any time.



1934 Kellogg Ave., Carlsbad, CA 92008
 Tel: 1-760-598-9899 • USA 1-800-839-6283 • 1-800-TEXMATE
 Fax: 1-760-598-9828 • Email: orders@texmate.com • Web: www.texmate.com

FL-B101D40-TC and FL-B101D40-RTD Technical Manual Copyright © 2020 Texmate Inc. All rights reserved. Published by: Texmate Inc. USA. Information in this Technical Manual is subject to change without notice due to correction or enhancement. The information described in this manual is proprietary to Texmate, Inc. and may not be copied, reproduced or transmitted, in whole or in part, in connection with the design, manufacture, or sale of apparatus, device or private label product without the express written consent of Texmate, Inc.