

FL-B101D40PF

Power Factor Bargraph Indicator

TEXMATE



LEOPARD FAMILY



This unit accepts an analog DC signal from a Power Factor transducer, ranging from 4-20mA, 0-1mA, 2VDC, 5VDC, and 10VDC.

It provides a bargraph and digital display of the reading in the format customary for Power Factor meters, with the bargraph centered at PF=1.0.

Lead and lag are indicated by the bargraph extending upward (lead) or downward (lag) with cos(theta) scale markings from LAG 0.5 to 1.0 to LEAD 0.5.

The digital display provides a corresponding numeric readout of the same data with LAG represented by negative sign.

General Features

- Choice of DC volts or DC current (header selectable)
- Mono color (red or green), 101 segment high brightness bargraph. Vertical or optional horizontal format.
- Red 4-digit LED display with a range of -0.50, 1, +0.50
Optional green digital display.
- Auto-sensing AC/DC power supply. For voltages between 85-265 V AC / 95-300 V DC (PS1) or 18-48 V AC / 10-72 V DC (PS2).
- 24 V DC excitation is available to power external 4/20mA transmitters.
- Provision to connect an external programming lockout switch.
- Provision for external DIM switch to reduce the brightest display setting by 50%.
- Optional NEMA-4 IP65, Clear dust & Splash proof front cover.
- Automatic intelligent averaging, smooths noisy signals while providing a fast display response to real level changes.
- UL Listed

Software Features

- Bargraph center zero function.
- Digital display blanking.
- Four-level brightness control accessed by the button and adjusted by the button.

Specifications

- Input Specs:** Header selectable current or voltage input signal
- Current input: 4-20mA with shunt 100ohm; 2mA range with shunt resistance 1kohm; (Voltage at full scale current input: 2V.)
 - Voltage input: 2V, 5V, 10V, input impedance 1 Mohm
- A/D Converter:** 14 bit single slope
- Accuracy:** ±(0.05% of reading + 2 counts)
- Temp. Coeff:** 100 ppm/°C (Typical)
- Warm up time:** 2 minutes
- Conversion Rate:** 10 conversions per second (Typical)
- Digital Display:** 4 digit 0.31" LED red (std), green (optn)
- Bargraph Display:** 101 seg. bar red / 4 digit 4" LED red (std) green(optn), horizontal (optn)
- Power Supply:** AC/DC Auto sensing wide range supply
- PS1 (std) 85-265 VAC / 95-300 VDC, 50-400Hz 4.2W
- PS2 18-48 VAC / 10-72 VDC, 50-400Hz 4.2W
- Operating Temp.:** 0 to 50°C
- Storage Temp.:** -20°C to 70°C
- Relative Humidity:** 95% (non condensing)
- Case Dimensions:** 9/64 DIN (Bezel 36Wx144Hmm)
- Depth behind bezel (5.83") 148mm
- Plus (0.7") 18mm for connectors
- Weight:** 9.5 oz., 12 oz when packed

Index

| | | | | | |
|--|---|--|----|--|---|
| Bargraph Center Point Display Mode Selection . . . | 5 | Digital Span Selection for Display | 5 | Software Features | 1 |
| Case Dimensions | 9 | General Features | 1 | Software Logic Tree | 3 |
| Component Layout. | 7 | Installation guidelines. | 9 | Specifications. | 1 |
| Connector Pinouts | 6 | Ordering Information | 10 | Two Point Analog Range Setting & Calibration | 7 |
| Connectors. | 6 | Panel Adaptor. | 8 | Two Point Digital Calibration Mode | 4 |
| Controls and Indicators | 2 | Pin Descriptions. | 6 | | |
| Decimal Point and Brightness Selection | 5 | Programming Conventions. | 2 | | |

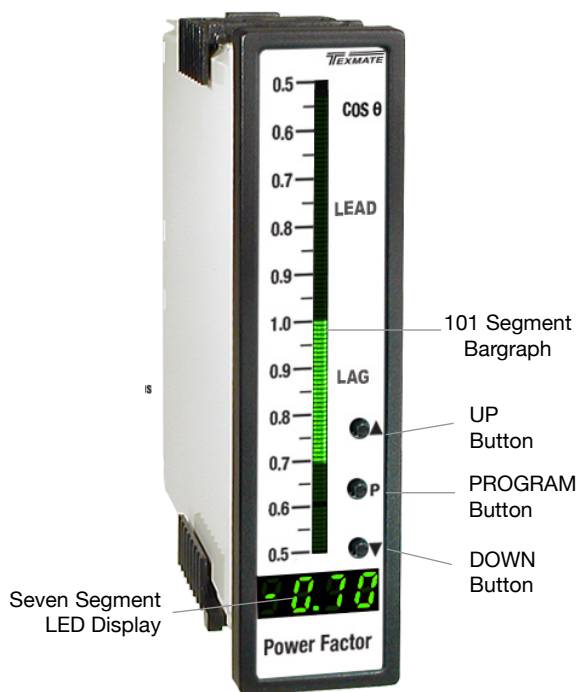

Front Panel Buttons

Program Button

The **P** button is used to move from one program step to the next. When pressed at the same time as the **↑** button, it initiates the **calibration mode**. When pressed at the same time as the **↓** button, it initiates the **setpoint setting mode**.

Up Button

When in the operational display, pressing the **↑** button allows you to view the setting of the saved **Peak and Valley Values**.

When setting a displayed parameter during programming, the **↑** button is used to increase the value of the displayed parameter.

Down Button

When in the operational display, pressing the **↓** button allows you to change the **Brightness Level**.

When setting a displayed parameter during programming, the **↓** button is used to decrease the value of the displayed parameter.

Front Panel LED Display

Digital LED Displays

The digital LED displays are used to display the meter input signal readings. They also display the programming settings during programming.

Programming Conventions

To explain software programming procedures, logic diagrams are used to visually assist in following the programming steps. The following symbols are used throughout the logic diagrams to represent the buttons and indicators on the meter:

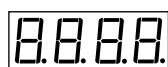

This symbol represents the OPERATIONAL DISPLAY.



This is the PROGRAM button.



This is the UP button.



This is the DOWN button.

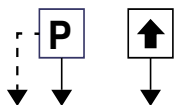

When a button is shown, press and release it to go onto the next step in the direction indicated by the arrow. When an alternative dotted line is shown, this indicates that an alternative logic branch will be followed when a particular option is present.

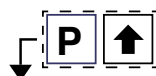

When two buttons are shown side by side and enclosed by a dotted line, they must be pressed at the same time then released to go onto the next programming step.

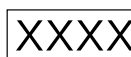

If an X appears through a digit, it means that any number displayed in that digit is not relevant to the function being explained.

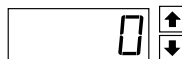

When the **↑** and **↓** buttons are shown together, the display value can be increased by pressing and releasing the **↑** button or decreased by pressing and releasing the **↓** button.



When the **↑** and **↓** buttons are shown with two displays, either display can be selected by pressing and releasing the **↑** or **↓** buttons.

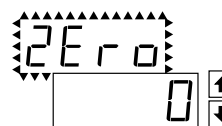

When two displays are shown together with bursts, this indicates that the display is toggling (flashing) between the name of the function and the value.

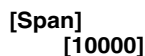

Text or numbers shown between square brackets in a procedure indicate the programming code name of the function or the value displayed on the meter display.

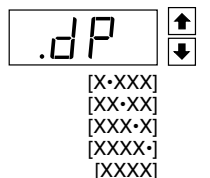

When there are more than two display selections they are shown in brackets below the first display and are also selectable by pressing and releasing the **↑** or **↓** buttons.

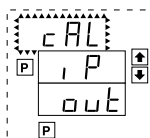

A dotted line enclosing an entire logic diagram indicates that programming branch will appear only when a particular option is present.

Software Logic Tree

The FL-B101D40PF is an intelligent bargraph meter with a hierarchical software structure designed for easy programming and operation, as shown below in the software logic tree.

Software Version is Displayed on Power-up

When power is applied, all segments of the bargraph and digital display light up for 3 seconds. The version number of the installed software is then displayed for 2 seconds, after which, the operational display indicates the input signal.

Note: The functions in grayed area are not applicable for this model.

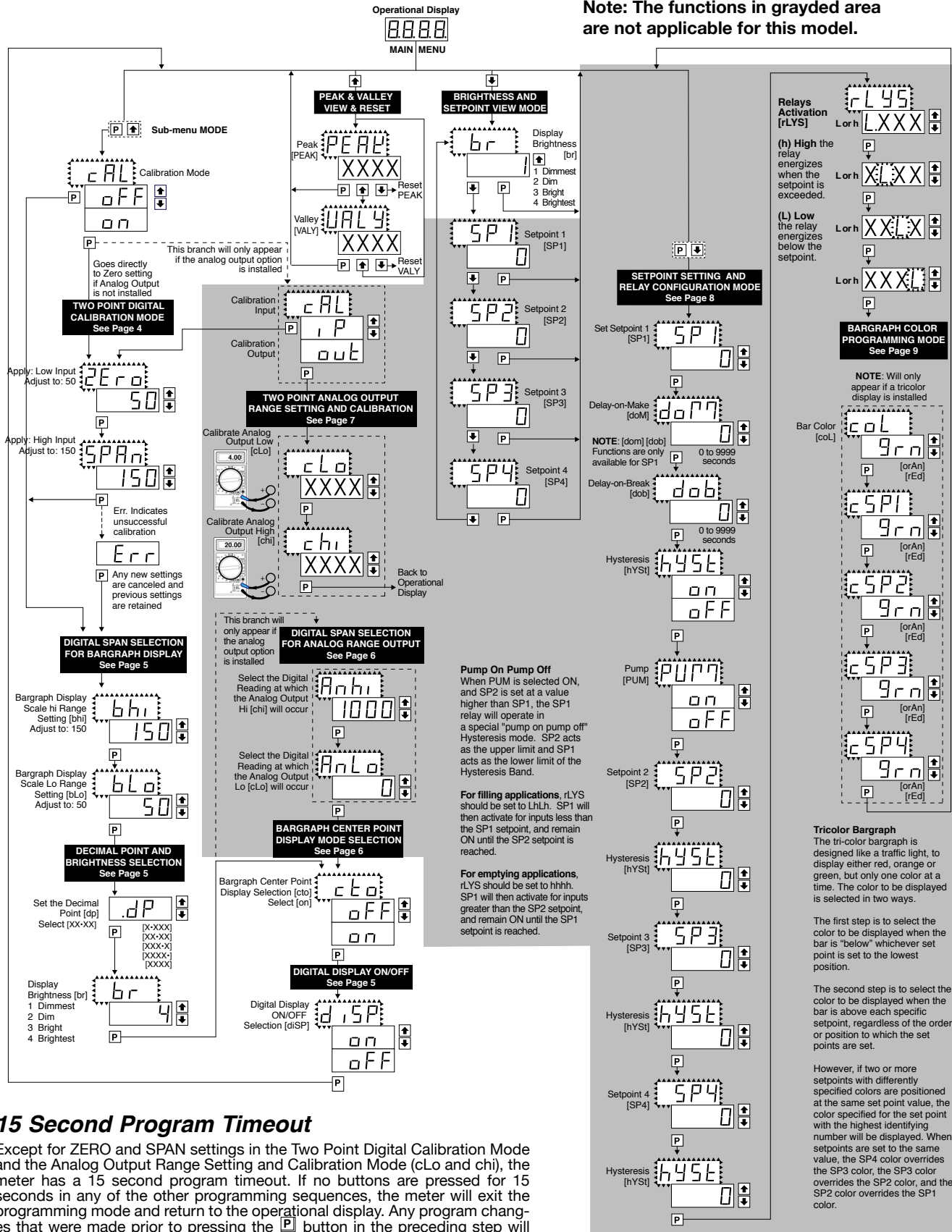

15 Second Program Timeout

Except for ZERO and SPAN settings in the Two Point Digital Calibration Mode and the Analog Output Range Setting and Calibration Mode (cLo and chi), the meter has a 15 second program timeout. If no buttons are pressed for 15 seconds in any of the other programming sequences, the meter will exit the programming mode and return to the operational display. Any program changes that were made prior to pressing the **P** button in the preceding step will not be saved.

Two Point Digital Calibration Mode

STEP A Enter the Calibration Mode

- 1) Press the **P** and **↑** buttons at the same time. Display toggles between [CAL] and [oFF].
- 2) Press the **↑** or **↓** button. Display changes from [oFF] to [on].
- 3) Press the **P** button. Display toggles between [ZEro] and the previous zero setting.

STEP B Set the Meter's Low Input Signal Reading on the Digital Display

- 1) Apply a low signal to the meter.
- 2) Using the **↑** and **↓** buttons, adjust the meter display to [50] reading for the applied low input signal.
- 3) Press the **P** button. Display toggles between [SPAN] and the previous span setting.

STEP C Set the Meter's High Input Signal Reading on the Digital Display

- 1) Apply a high input signal to the meter.
- 2) Using the **↑** and **↓** buttons, adjust the digital display to [150] reading for the applied high input signal.
- 3) Press the **P** button.

The Digital Calibration Procedure is now complete.

If the digital calibration was successfully completed, the menu branches to the Digital Span Selection for Bargraph Display, and the display flashes [bhi] and the previous setting.

ERROR Indicates Unsuccessful Calibration

If the calibration was unsuccessful, the display indicates [Err], the new calibration settings just entered will not take effect and the previously stored setting will remain. The three most likely causes of an error during calibration are:

1. The full scale and zero signals were too similar. The full scale signal must be at least 1000 counts greater than the zero or low input signal (positive and negative values are allowed).
2. The scaling requirement exceeded the digital display span capability of the meter (12,000 counts between -1999 to 9999).
3. No input signal present, or incorrect input signal connections.

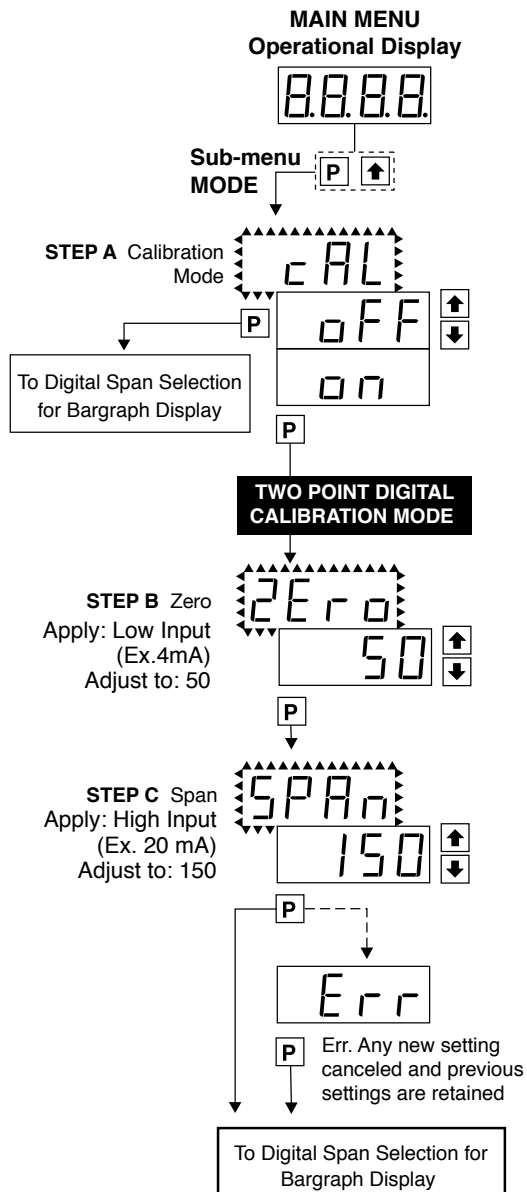

Digital Span Selection For Bargraph Display

STEP A Enter the Calibration Sub Menu Mode

- 1) Press the and buttons at the same time. Display toggles between [CAL] and [oFF].
- 2) Press the button. Display toggles between [bhi] and the previous setting.

STEP B Set the Digital Span of the Bargraph Display

- 1) Using the and buttons, adjust the display to [150] high parameter reading.
- 2) Press the button. Display toggles between [bLo] and the previous setting.
- 3) Using the and buttons, adjust the display to [50] low parameter reading.
- 4) Press the button. Display changes from [50] to [dP].

Decimal Point and Brightness Selection

STEP C Set the Decimal Point

- 1) Using the and buttons, adjust the display to the [XX.XX] decimal point setting.
- 2) Press the button. Display toggles between [br] and the previous brightness setting.

STEP D Set the Bargraph and Digital Display Brightness

- 1) Using the and buttons, adjust the display to the desired brightness setting (4 is the brightest setting).
- 2) Press the button. Display toggles between [Cto] and [oFF]

Bargraph Center Point Display Mode Selection

STEP G Bargraph Center Point Mode Selection (See example above)

- 1) To select bargraph center point mode, press the or button. Display changes from [oFF] to [on].
- 2) Press the button. Display toggles between [diSP] and [on] or [oFF].

STEP H Digital Display ON/OFF Selection

- 1) To set the display to [oFF], press the or button. Display toggles between [diSP] and [oFF].
- 2) Press the button. The display exits the calibration mode and returns to the operational display. Only the bargraph display is on and the digital display is off.

If the digital display is selected to be off, pressing any button to make programming changes or to view setpoints activates the digital display. When the procedure is complete, the digital display will then automatically switch off.

The Display/Bargraph settings are now complete.

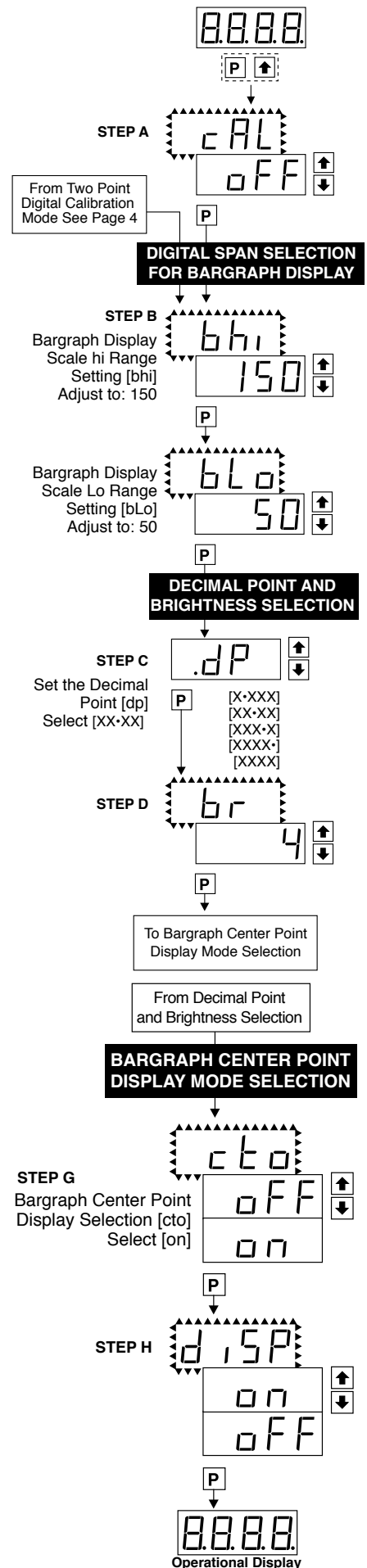

Connector Pinouts

This meter uses plug-in type screw terminal connectors for all input and output connections. The power supply connections (pins 23 and 24) have a unique plug and socket outline to prevent cross connection. The main board uses standard right-angled connectors.

Replacement 2-, 3-, and 4-pin plug connectors are available (see Accessories on page 10).

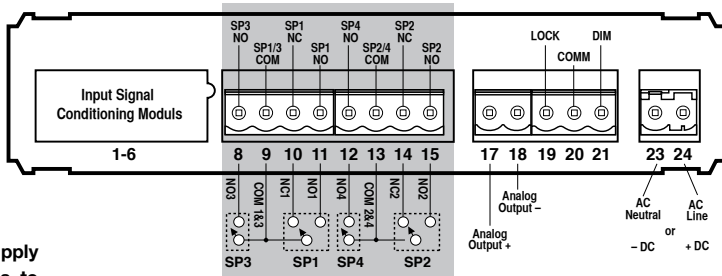

Note: Gray shaded area is not applicable to this model.



WARNING: AC and DC input signals and power supply voltages can be hazardous. Do Not connect live wires to screw terminal plugs, and do not insert, remove or handle screw terminal plugs with live wires connected.

Pin Descriptions

Input Signal – Pins 1 to 6

Pins 1 to 6 are reserved for the input signal conditioner. See the data sheet for the selected input signal conditioner.

Pins 17 to 21 – Rear Panel Switches

- Pin 19** **Programming LOCK.** By connecting the LOCK pin to the COMMON pin, the meter's programmed parameters can be viewed but not changed.
- Pin 20** **COMMON.** To activate the LOCK or DIM functions from the rear of the meter, the respective pins have to be connected to the COMMON pin. This pin is connected to the internal power supply ground.
- Pin 21** **DIM.** By connecting the display dim (DIM) pin to the COMMON pin, the display brightness setting is halved.

Pins 23 and 24 – AC/DC Power Input

Auto-sensing AC/DC power supply. For voltages between 85-265 V AC / 95-300 V DC (PS1) or 18-48 V AC / 10-72 V DC (PS2).

- Pin 23** **AC Neutral / -DC.** Neutral power supply line.
- Pin 24** **AC line / +DC.** Live power supply line.

Connectors



WARNING

AC and DC input signals and power supply voltages can be hazardous. Do Not connect live wires to terminal blocks, and do not insert, remove or handle terminal blocks with live wires connected.

Standard plug-in screw terminal blocks provided by Texmate:

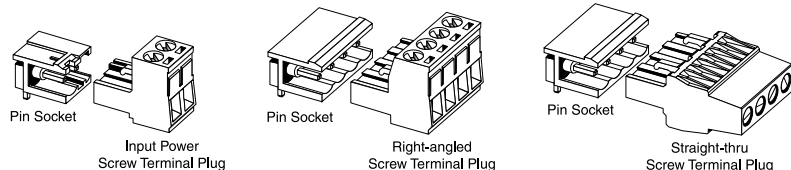

MAIN BOARD

Hi Voltage

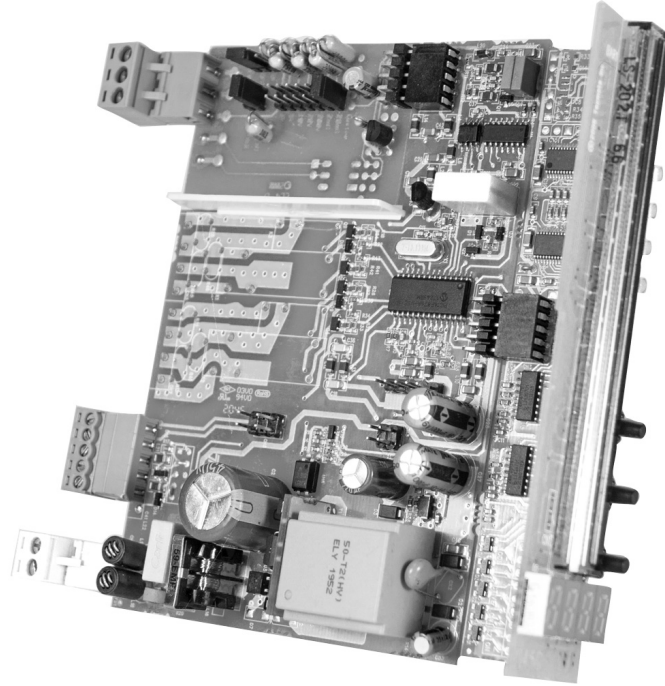

INPUT MODULE

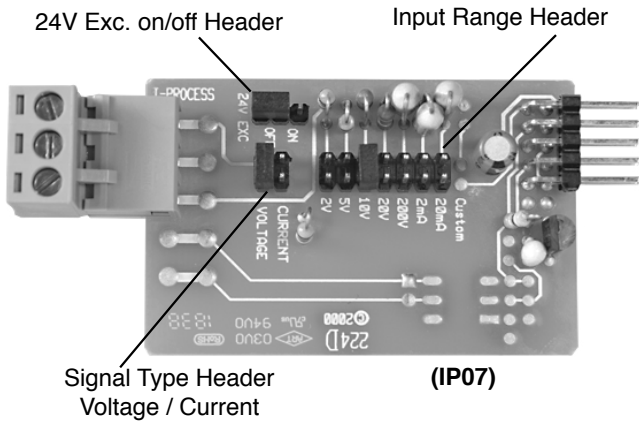

IP07: Universal Process Input
2V/5V/10V/20V/200V/2mA/20mA/Custom

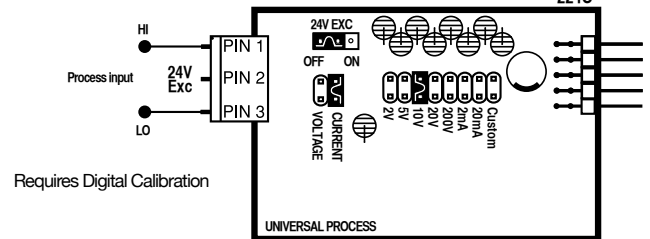

Fits 6" Edgewise Pointer Meter Cut-Outs

The adapter snaps on the 36x144 mm (1.42"x5.69") case and enables single unit or stack mounting in an existing 6" edgewise pointer meter cut-out.

When extra panel mounting tightness is required, order the optional screw mount clip. P/N (OPMTLCLIP)

Adapter uses wide jaw mouting slide clips. P/N (75-DMC14436B)

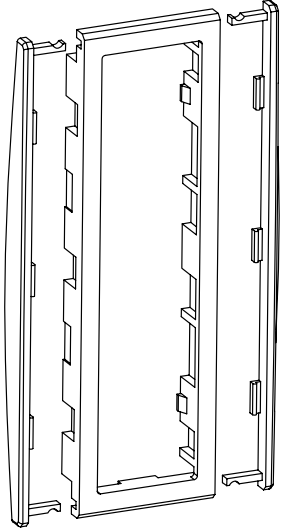

Panel Adapter
Part #: OP-PA/144X36

Fits existing cut-outs for 6" (150 mm) edgewise switchboard pointer meters from:

- Crompton
- G.E.
- Westinghouse
- Yokogawa
- and most others

Width: 43.7 mm to 48 mm (1.72" to 1.89")
Height: 143.4 mm to 149 mm (5.62" to 5.88")

Two bezel trim strips are provided with each adapter to finish off the edge of each individually mounted meter or the edge of each stack mounted array.

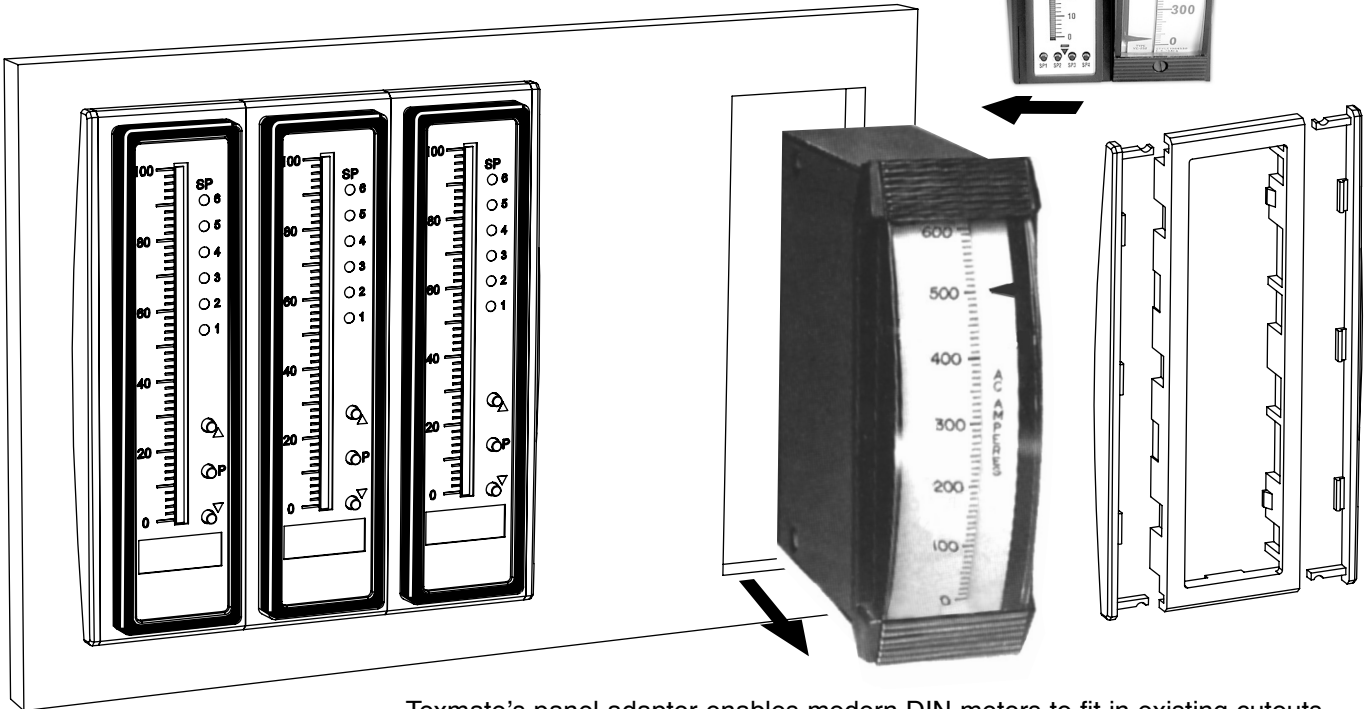
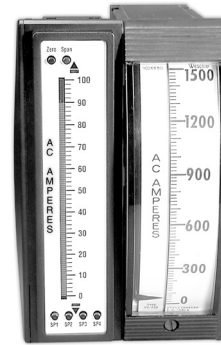
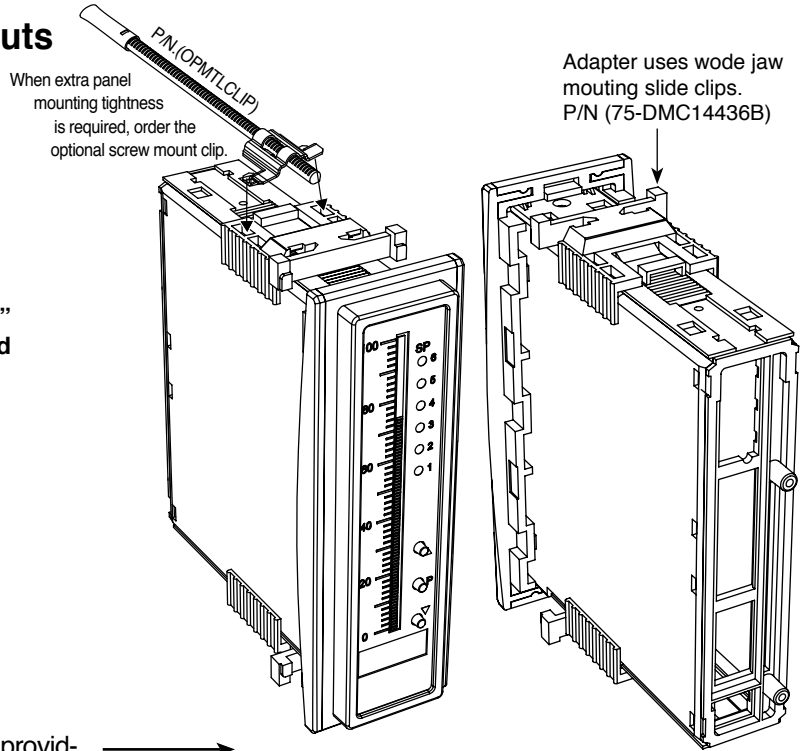

Texmate's panel adapter enables modern DIN meters to fit in existing cutouts individually or stacked when replacing old 6" edgewise mechanical pointer meters.

Installation

1. Install and wire meter per local applicable codes/regulations, the particular application, and good installation practices.

2. Install meter in a location that does not exceed the maximum operating temperature and that provides good air circulation.

3. Separate input/output leads from power lines to protect the meter from external noise. Input/output leads should be routed as far away as possible from contactors, control relays, transformers and other noisy components. Shielding cables for input/output leads is recommended with shield connection to earth ground near the meter preferred.

4. A circuit breaker or disconnect switch is required to disconnect power to the meter. The breaker/switch should be in close proximity to the meter and marked as the disconnecting device for the meter or meter circuit. The circuit breaker or wall switch must be rated for the applied voltage (e.g., 120VAC or 240VAC) and current appropriate for the electrical application (e.g., 15A or 20A).

5. See *Case Dimensions* section for panel cutout information.

6. See *Connector Pinouts* section for wiring.

7. Use 28-12 AWG wiring, minimum 90°C (HH) temperature rating. Strip wire approximately 0.3 in. (7-8 mm).

8. Recommended torque on all terminal plug screws is 4.5 lb-in (0.51 N-m).



Case Dimensions

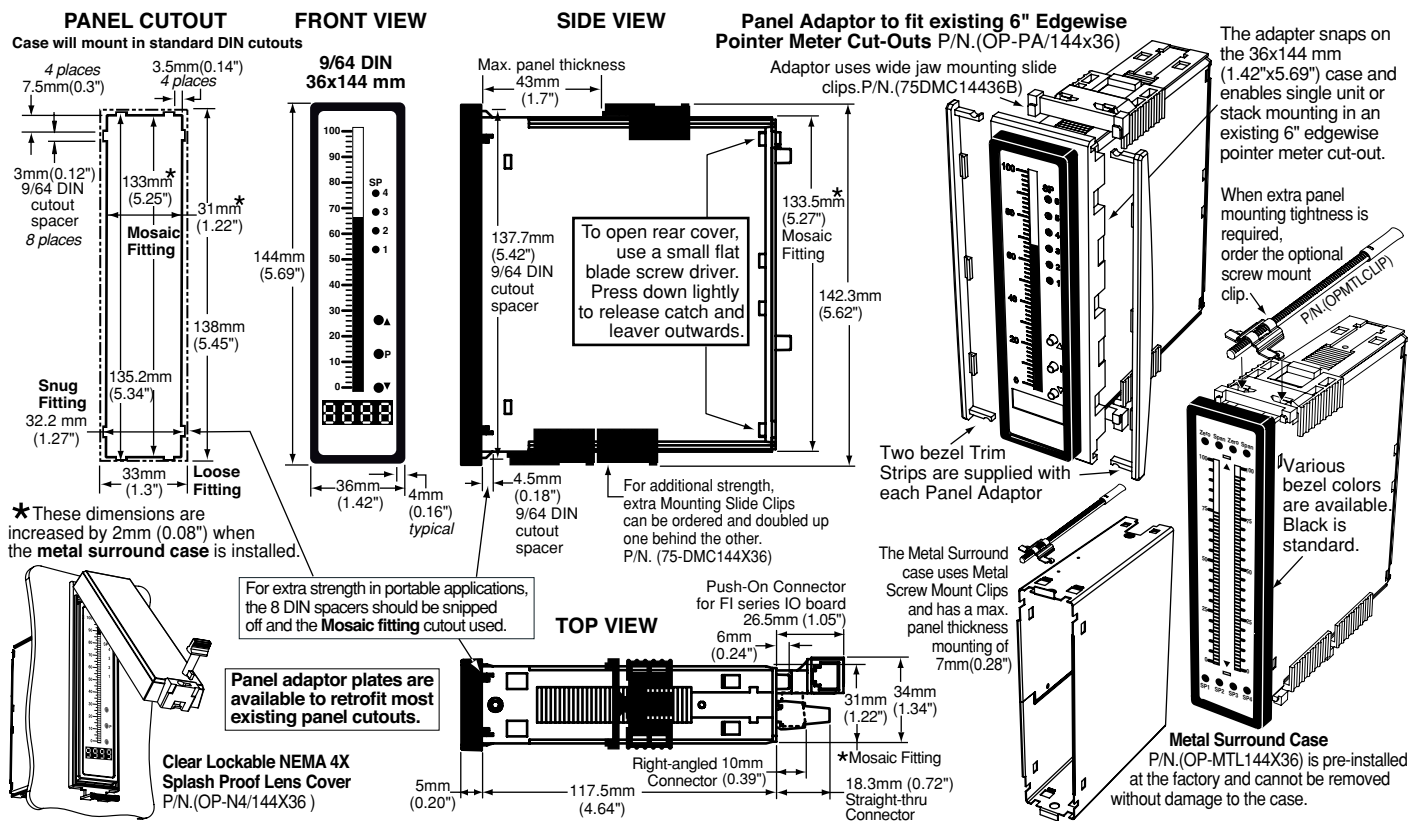

Ordering Information

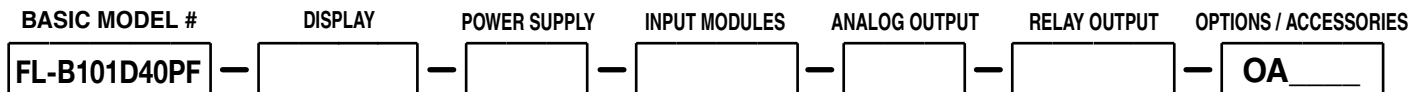

Add to the basic model number the order code suffix for each standard option required. The last suffix is to indicate how many different special options and or accessories that you may require to be included with this product.

Ordering Example: FL-B101D40SF-VRR-PS1-IP07-OA1 plus an OP-N4/144X36

► BASIC MODEL NUMBER

FL-B101D40PF 144x36mm, 101 Segment Bargraph, 4 Digit, Scale Factor

Standard Options for this Model Number

| Order Code Suffix | Description |
|-------------------|-------------|
|-------------------|-------------|

► DISPLAY

| | |
|------|--|
| VRR | Red LED Bargraph w/4 Digit Red DPM, Vertical |
| VGG | Green LED Bargraph w/4 Digit Green DPM, Vertical |
| VGR | Green LED Bargraph w/4 Digit Red DPM, Vertical |
| VRG | Red LED Bargraph w/4 Digit Green DPM, Vertical |
| HRR | Red LED Bargraph w/4 Digit Red DPM, Horizontal |
| HGG | Green LED Bargraph w/4 Digit Green DPM, Horizontal |
| HGR | Green LED Bargraph w/4 Digit Red DPM, Horizontal |
| HRG | Red LED Bargraph w/4 Digit Green DPM, Horizontal |
| DSGG | Dual Scale Green LED Vertical Bargraph w/4 Digit Green DPM |
| DSGR | Dual Scale Green LED Vertical Bargraph w/4 Digit Red DPM |
| DSRG | Dual Scale Red LED Vertical Bargraph w/4 Digit Green DPM |
| DSRR | Dual Scale Red LED Vertical Bargraph w/4 Digit Red DPM |

► POWER SUPPLY

| | |
|-----|----------------------|
| PS1 | .85-265VAC/95-300VDC |
| PS2 | 18-48VAC/10-72VDC |

► INPUT MODULES

| | |
|------|--|
| IP07 | Universal Process 2V/5V/10V/20V/200V/2mA/20mA/Custom |
|------|--|

Special Options and Accessories

| Part Number | Description | List |
|-------------|-------------|------|
|-------------|-------------|------|

► SPECIAL OPTIONS (Specify Inputs or Outputs & Req. Reading)

| | | |
|----|--|--|
| ZR | Range change from Standard Range shown in BOLD Type | |
|----|--|--|

► ACCESSORIES (Specify Serial # for Custom Artwork Installation)

| | | |
|--------------|---|--|
| 75-DMC14436B | Side Slide Brackets-Wide opening (2 pc) | |
| 75-DMC144X36 | Side Slide Brackets-stand. (2 pc) - extra set | |
| 93-PLUG2P-DP | Extra Screw Terminal Conn., 2 Pin Power Plug | |
| 93-PLUG2P-DR | Extra Screw Terminal Conn., 2 Pin Plug | |
| 93-PLUG3P-DR | Extra Screw Terminal Conn., 3 Pin Plug | |
| 3-PLUG4P-DR | Extra Screw Terminal Conn., 4 Pin Plug | |
| 93-PLUG5P-DR | Extra Screw Terminal Conn., 5 Pin Plug | |
| OP-MTL144x36 | Metal Surround Case, includes screw mounting clips | |
| OP-MTLCLIP | Screw Mounting Clips (2 pc) - to screw tighten slide brackets | |
| OP-N4/144X36 | 144x36mm clear lockable front cover-NEMA 4X, splash proof | |
| OP-PA/144X36 | Panel Adapter for 144x36mm from 6 inch cutout | |

Prices subject to change without notice.

WARRANTY

Texmate warrants that its products are free from defects in material and workmanship under normal use and service for a period of one year from date of shipment. Texmate's obligations under this warranty are limited to replacement or repair, at its option, at its factory, of any of the products which shall, within the applicable period after shipment, be returned to Texmate's facility, transportation charges pre-paid, and which are, after examination, disclosed to the satisfaction of Texmate to be thus defective. The warranty shall not apply to any equipment which shall have been repaired or altered, except by Texmate, or which shall have been subjected to misuse, negligence, or accident. In no case shall Texmate's liability exceed the original purchase price. The aforementioned provisions do not extend the original warranty period of any product which has been either repaired or replaced by Texmate.

USER'S RESPONSIBILITY

We are pleased to offer suggestions on the use of our various products either by way of printed matter or through direct contact with our sales/application engineering staff. However, since we have no control over the use of our products once they are shipped, NO WARRANTY WHETHER OF MERCHANTABILITY, FITNESS FOR PURPOSE, OR OTHERWISE is made beyond the repair, replacement, or refund of purchase price at the sole discretion of Texmate. Users shall determine the suitability of the product for the intended application before using, and the users assume all risk and liability whatsoever in connection therewith, regardless of any of our suggestions or statements as to application or construction. In no event shall Texmate's liability, in law or otherwise, be in excess of the purchase price of the product.

Texmate cannot assume responsibility for any circuitry described. No circuit patent or software licenses are implied. Texmate reserves the right to change circuitry, operating software, specifications, and prices without notice at any time.



1934 Kellogg Ave., Carlsbad, CA 92008

Tel: 1-760-598-9899 • 1-800-TEXMATE

Fax: 1-760-598-9828 • Email: orders@texmate.com

FL-B101D40PF Technical Manual Copyright © 2021 Texmate Inc. All rights reserved. Published by: Texmate Inc. USA. Information in this Technical Manual is subject to change without notice due to correction or enhancement. The information described in this manual is proprietary to Texmate, Inc. and may not be copied, reproduced or transmitted, in whole or in part, in connection with the design, manufacture, or sale of apparatus, device or private label product without the express written consent of Texmate, Inc.