

FL-B101D40PS

Leopard Bargraph Meter
101 Segment, 4 Digit 0.32" LEDs
in a 9/64 DIN CASE

This smart Tricolor or Mono-color digital bargraph with programmable scale factor has four fully programmable set points for monitoring, measurement, and control applications.



General Features

- External transmitters or signal conditioners can be eliminated by direct connection of the sensor output to more than 40 Plug-in Input Signal Conditioners that include:
 - AC/DC Current
 - AC/DC Voltage
 - Load Cell
 - Pressure
 - Process
 - Prototype
 - Resistance
 - Temperature
 - 4 to 20 mA
- Optional isolated 16 bit analog output. User or factory scalable to 4 to 20 mA, 0 to 20 mA or 0 to 10 V across any desired digital span from \pm one count to the full scale range of -1999 to 9999 (12000 counts).
- A Programmable Tricolor (Red-Green-Orange) or mono color (red or green), 101 segment high brightness bargraph. Vertical or optional horizontal format.
- Red 4-digit LED display with a range of -1999 to 9999 (12000 counts). Optional green digital display.
- Front panel LED annunciators provide indication of setpoint status.
- Two 10 Amp Form C, and two 5 Amp Form A relays available
- Auto-sensing AC/DC power supply. For voltages between **85-265 V AC / 95-370 V DC (PS1)** or 18-48 V AC / 10-72 V DC (PS2).
- 24 V DC excitation is available to power external 4/20mA transmitters and 5 or 10 V DC excitation is available for resistance bridge type sensors.
- Provision to connect an external programming lockout switch.
- Provision for external DIM switch to reduce the brightest display setting by 50%.
- Optional NEMA-4 front cover.
- Automatic intelligent averaging, smooths noisy signals while providing a fast display response to real level changes.

Software Features

- The bargraph can display, full scale, any desired portion of the digital reading.
- Bargraph center zero function.
- Four programmable setpoints with adjustable Hysteresis.
- Setpoint 1 has delay-on-make and delay-on-break plus a special "pump on pump off" mode that creates a Hysteresis Band between SP1 and SP2.
- Relay activation can be selected to occur above (hi) or below (Lo) each setpoint.
- Digital display blanking.
- Decimal point setting.
- Four-level brightness control accessed by the \uparrow button and adjusted by the \downarrow button.

Input Module Compatibility

LEOPARD FAMILY: More than 38 different Plug-in I-Series Input Signal Conditioners are approved for Texmate's Leopard Family of meters. Some examples are shown on pages 13 - 15. See www.texmate.com for an up to date listing.



Specifications

Input Specs: Depends on Input signal conditioner
A/D Converter: 14 bit single slope
Accuracy: $\pm(0.05\%$ of reading + 2 counts)
Temp. Coeff.: 100 ppm/ $^{\circ}$ C (Typical)
Warm up time: 2 minutes
Conversion Rate: 10 conversions per second (Typical)
Digital Display: **4 digit 0.31" LED red (std)**, green (optn)
 Range -1999 to 9999 counts.
Bargraph Display: **101 segment 4" red vertical (std)**,
 green or tricolor (optn), horizontal (optn)
Polarity: Assumed positive. Displays - negative
Decimal Selection: Front panel button selectable, X•X•X•X•
Positive Overrange: Bargraph and top segments of digital display flash.
Negative Overrange: First segment of bargraph and bottom segments of digital display flash.
Relay Output: Two 5 Amp Form A relays and Two 10 Amp Form C relays.
Analog Output: Isolated 16 bit user scalable mA or V
 OIC (mA out) 4-20 mA @ 0 to 500 Ω max loop resistance
 OIV (volts out) 0-10 V DC @ 500 Ω or higher resistance
Power Supply: AC/DC Auto sensing wide range supply
PS1 (std) **85-265 VAC / 95-370 VDC @ 2.5W max 4.2W**
PS2 18-48 VAC / 10-72 VDC @ 2.5W max 4.2W
Operating Temp.: 0 to 60 $^{\circ}$ C
Storage Temp: -20 $^{\circ}$ C to 70 $^{\circ}$ C
Relative Humidity: 95% (non condensing)
Case Dimensions: 9/64 DIN (Bezel 36Wx144Hmm)
 Depth behind bezel (5.83") 148mm
 Plus (0.7") 18mm for connectors
Weight: 9.5 oz., 12 oz when packed

Index

Bargraph Center Point Display Mode Selection . . . 7	Digital Span Selection for Display 6	Programming Conventions 2
Bargraph Color Programming Mode 10	Digital Span Selection for Analog Range Output . . 7	Setpoint Setting & Relay Conf. Mode . . . 9-10
Case Dimensions 8	Functional Diagram 11	Software Features 1
Component Layout 12	General Features 11	Software Logic Tree 3
Connector Pinouts 11	I-Series Input Signal Conditioning Modules . . 13-15	Specifications 1
Connectors 12	Input Module Calibration Procedures 17	Standard Faceplates and Scales 18
Controls and Indicators 2	Input Module Component Glossary 16	Successive Digital Rescaling 5
Custom Faceplates and Scales 19	Ordering Information 20	Two Point Analog Range Setting & Calibration . . 8
Decimal Point and Brightness Selection 6	Pin Descriptions 11	

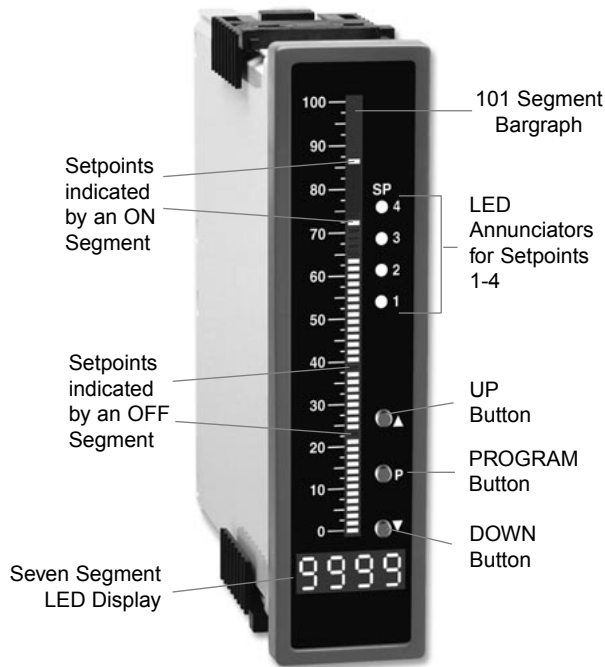

Front Panel Buttons

Program Button

The **P** button is used to move from one program step to the next. When pressed at the same time as the **↑** button, it initiates the **calibration mode**. When pressed at the same time as the **↓** button, it initiates the **setpoint setting mode**.

Programming Conventions

To explain software programming procedures, logic diagrams are used to visually assist in following the programming steps. The following symbols are used throughout the logic diagrams to represent the buttons and indicators on the meter:

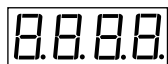

This symbol represents the OPERATIONAL DISPLAY.



This is the PROGRAM button.



This is the UP button.



This is the DOWN button.

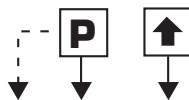

When a button is shown, press and release it to go onto the next step in the direction indicated by the arrow. When an alternative dotted line is shown, this indicates that an alternative logic branch will be followed when a particular option is present.



When two buttons are shown side by side and enclosed by a dotted line, they must be pressed at the same time then released to go onto the next programming step.



If an X appears through a digit, it means that any number displayed in that digit is not relevant to the function being explained.

Up Button

When in the operational display, pressing the **↑** button allows you to view the setting of the saved **Peak and Valley Values**.

When setting a displayed parameter during programming, the **↑** button is used to increase the value of the displayed parameter.

Down Button

When in the operational display, pressing the **↓** button allows you to change the **Brightness Level** as well as to view the setting of the setpoints **SP1, SP2, SP3 & SP4**.

When setting a displayed parameter during programming, the **↓** button is used to decrease the value of the displayed parameter.

Front Panel LED Display

Annunciator LEDs

The annunciator LEDs indicate the alarm status. They are labeled from bottom to top: SP1, SP2, SP3, SP4.

Digital LED Displays

The digital LED displays are used to display the meter input signal readings. They also display the programming settings during programming.

Setpoint Indication

The position of setpoints on the bargraph display are indicated by an ON or OFF segment dependent on the bargraph display being above or below the setpoint.



When the **↑** and **↓** buttons are shown together, the display value can be increased by pressing and releasing the **↑** button or decreased by pressing and releasing the **↓** button.

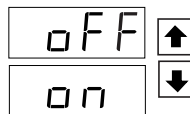

When the **↑** and **↓** buttons are shown with two displays, either display can be selected by pressing and releasing the **↑** or **↓** buttons.

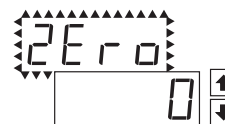

When two displays are shown together with bursts, this indicates that the display is toggling (flashing) between the name of the function and the value.



Text or numbers shown between square brackets in a procedure indicate the programming code name of the function or the value displayed on the meter display.

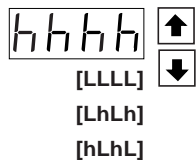

When there are more than two display selections they are shown in brackets below the first display and are also selectable by pressing and releasing the **↑** or **↓** buttons.

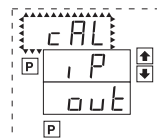

A dotted line enclosing an entire logic diagram indicates that programming branch will appear only when a particular option is present.

Software Logic Tree

The FL-B101D40PS is an intelligent bargraph meter with a hierarchical software structure designed for easy programming and operation, as shown below in the software logic tree.

Software Version is Displayed on Power-up
When power is applied, all segments of the bargraph and digital display light up for 3 seconds. The version number of the installed software is then displayed for 2 seconds, after which, the operational display indicates the input signal.

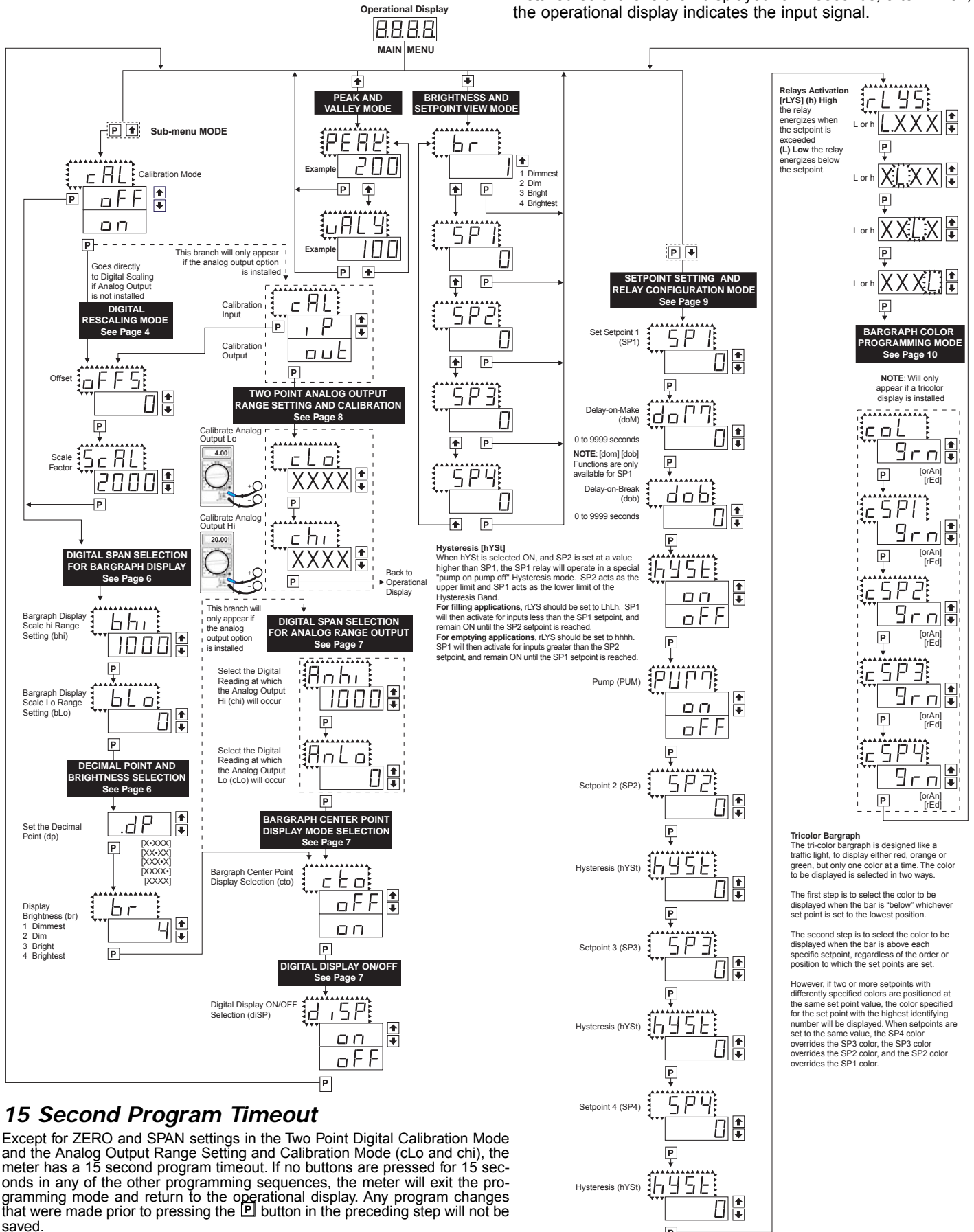

15 Second Program Timeout

Except for ZERO and SPAN settings in the Two Point Digital Calibration Mode and the Analog Output Range Setting and Calibration Mode (cLo and chi), the meter has a 15 second program timeout. If no buttons are pressed for 15 seconds in any of the other programming modes, the meter will exit the programming mode and return to the operational display. Any program changes that were made prior to pressing the **P** button in the preceding step will not be saved.

Digital Rescaling

The FL-B10140PSF meter may be rescaled without applying an external signal by changing the Offset and Scale factor.

Offset is the reading that the meter will display for a zero input. The Offset may be set to any value from -1999 to +9999. The default value of the Offset is 000

Scale factor is the gain of the meter. The displayed reading is directly proportional to the Scale factor. The default value of the scale factor is 2000, but it may be set to any value between -1999 and +9999.

For an input of 2V a calibrated meter will read 2000 with the default Scale factor of 2000, 3000 with a Scale factor of 3000 and 500 with a Scale factor of 500

If a linear scale is represented by $mx + b$, then the Scale Factor corresponds to the slope 'm' and the Offset corresponds to the intercept 'b'

The internal Signal Span is limited to 3 V DC between - 1 V DC to + 2 V DC. Outputs from an Input Signal Conditioning module that exceed these limits will cause the meter to indicate overrange.

Note: Most input signal conditioners have provisions for analog calibration and scaling. If the meter's digital Scale Factor is set to 2000 and Offset set to 0000 then, any pre-calibrated signal conditioner with an output that does not exceed - 1 V to + 2 V, will read correctly in the meter without any further calibration.

Digital Rescaling Procedure

STEP A Enter the Calibration Mode

- 1) Press the **[P]** and **[↑]** buttons at the same time. Display toggles between [CAL] and [oFF].
- 2) Press the **[↑]** or **[↓]** button. Display changes from [oFF] to [on].
- 3) Press the **[P]** button. Display toggles between [CAL] and [out].

Note: If at this point, the display skips directly to STEP C and toggles between [ScAL] and the previous [ScAL] setting, the software is detecting that the optional analog output hardware is NOT installed.

STEP B Select Two Point Digital Calibration of Input Signal

- 1) Press the **[↑]** or **[↓]** button to select CAL [iP] for input signal calibration.
- 2) Press the **[P]** button. Display toggles between [oFFS] and the previous offset setting.

STEP C Set the Offset on the Digital Display

- 1) Using the **[↑]** and **[↓]** buttons, adjust the digital display to the desired offset. This is the reading that the meter will display for a zero input
- 2) Press the **[P]** button. Display toggles between [ScAL] and the previous Scale factor.

STEP D Set the Scale factor on the Digital Display

- 1) Using the **[↑]** and **[↓]** buttons, adjust the meter display to the desired Scale factor. The default value is 2000, for which a 2V input will read 2000. If the scale factor is changed the display will change proportionately. Therefore if the Scale factor is changed to 1000 then for the same 2V input the display would read 1000.
- 3) Press the **[P]** button.

The Digital Rescaling is now complete.

If the Digital Rescaling was successfully completed, the menu branches to the Digital Span Selection for Bargraph Display (see page 6), and the display flashes [bhi] and the previous setting.

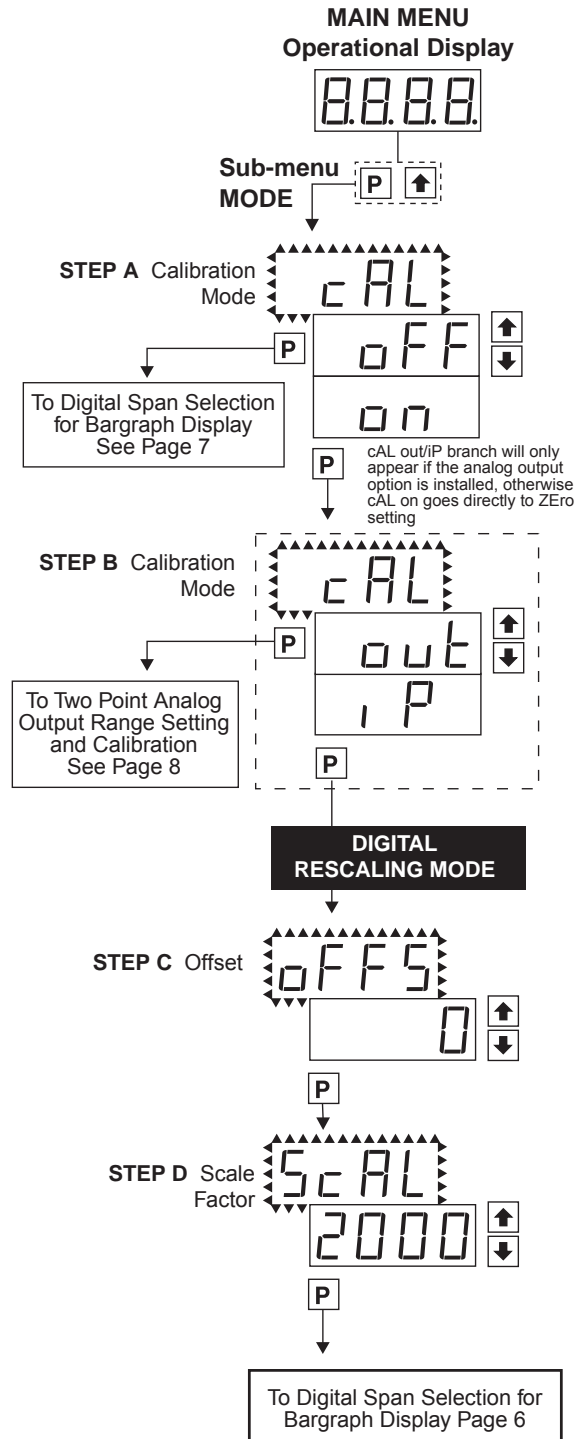

Successive Digital Rescaling to get Progressively Better Accuracy

STEP A

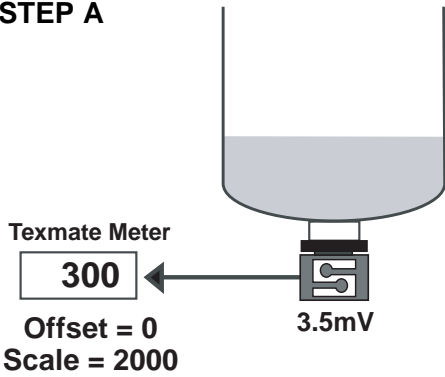

Hopper contains some material whose EXACT weight is not known.

It is estimated to be 320 pounds.
When a Texmate meter is connected, it displays 300 instead of 320.

STEP B

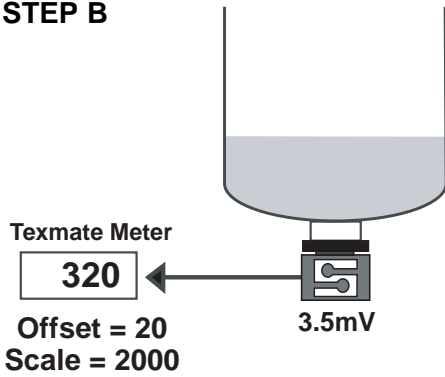

Change offset to +20 to correct the Texmate meter display to 320.

STEP C

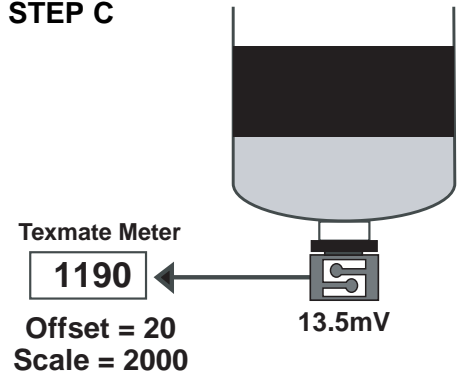

A known load of EXACTLY 1000 pounds is now added to the hopper.

Texmate meter displays 1190 instead of 1320.

STEP D

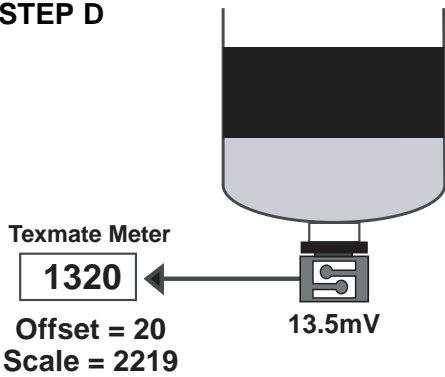

Change scale to 2219 to correct the Texmate meter display to 1320

$$\text{New scale} = 2000 \times 1320 / 1190 = 2219$$

The meter is approximately calibrated. Approximate, **not** exact, because the weight in STEP B is not exactly known.

STEP E

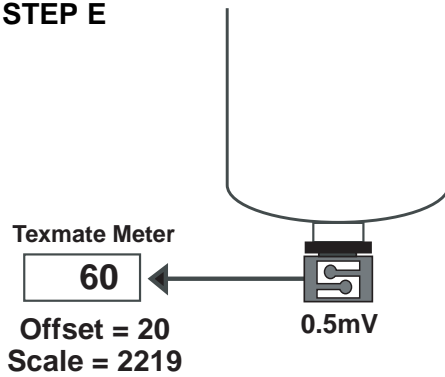

Later (maybe many days later) when the hopper is finally empty, it is seen that the meter does not read zero.

STEP F

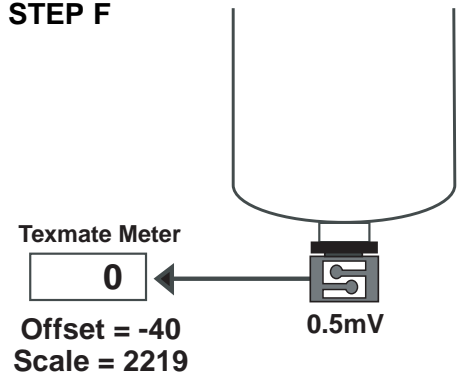

Change Offset to -40 to correct the Texmate meter display.

Display is now correct.

STEP G

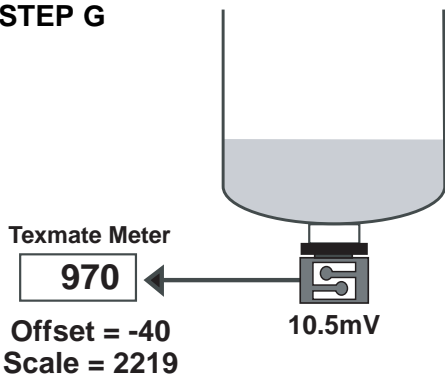

If a known weight of 1000 pounds is now added, the Texmate meter displays 970 instead of 1000.

error = 30 pounds

STEP H

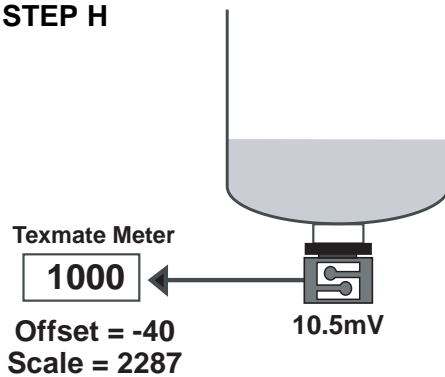

Change Scale to correct this display.

$$\text{New Scale} = 2219 \times 1000 / 970 = 2287$$

STEP I

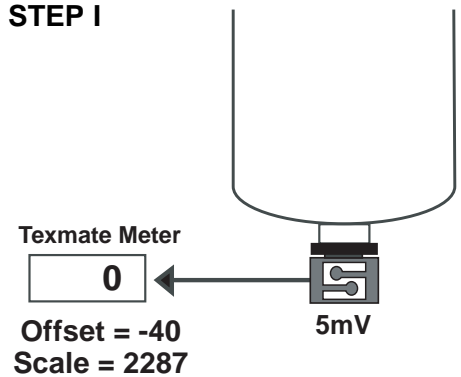

The next time the hopper is empty, it will read 0 correctly.

Digital Span Selection For Bargraph Display

The bargraph can be set to display full scale (0-101 bars) any portion of the digital reading from a minimum of 100 counts to a maximum of 12,000 counts. This provides higher resolution bargraph indication for those applications where the normal operating input signal range is less than the desired full scale display range of the digital display.

For Example:

If the full scale range of the meter has been set from -1999 to 9999 (0-12,000 counts), but the normal operating range of the input signal is between 4000 & 6000. The bargraph high parameter [bhi] can be set to 6000 and the bargraph low parameter [bLo] can be set to 4000.

This means that although the meter could digitally display a signal from -1999 to 9999 (0-12,000 counts), the bargraph display only begins to function at a reading of 4000, and reaches full scale indication at a reading of 6000. Although the digital display will continue reading up to 9999 before indicating overrange, the bargraph display will indicate its overrange by flashing for readings above 6000.

Example of Setting the Digital Span of the Bargraph Display to be Different than the Digital Display Range

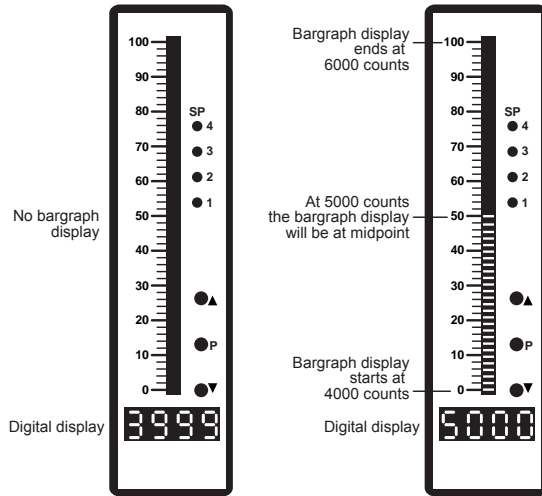

Bargraph does not light up for Input Signals up to 3999 counts

Bargraph lights up for Input Signals above 4000 counts

STEP A Enter the Calibration Sub Menu Mode

- 1) Press the **[P]** and **[↑]** buttons at the same time. Display toggles between [CAL] and [oFF].
- 2) Press the **[P]** button. Display toggles between [bhi] and the previous setting.

STEP B Set the Digital Span of the Bargraph Display (See example above)

- 1) Using the **[↑]** and **[↓]** buttons, adjust the display to the desired high parameter reading, e.g. 6000 counts.
- 2) Press the **[P]** button. Display toggles between [bLo] and the previous setting.
- 3) Using the **[↑]** and **[↓]** buttons, adjust the display to the desired low parameter reading, e.g. 4000 counts.
- 4) Press the **[P]** button. Display changes from [4000] to [dP].

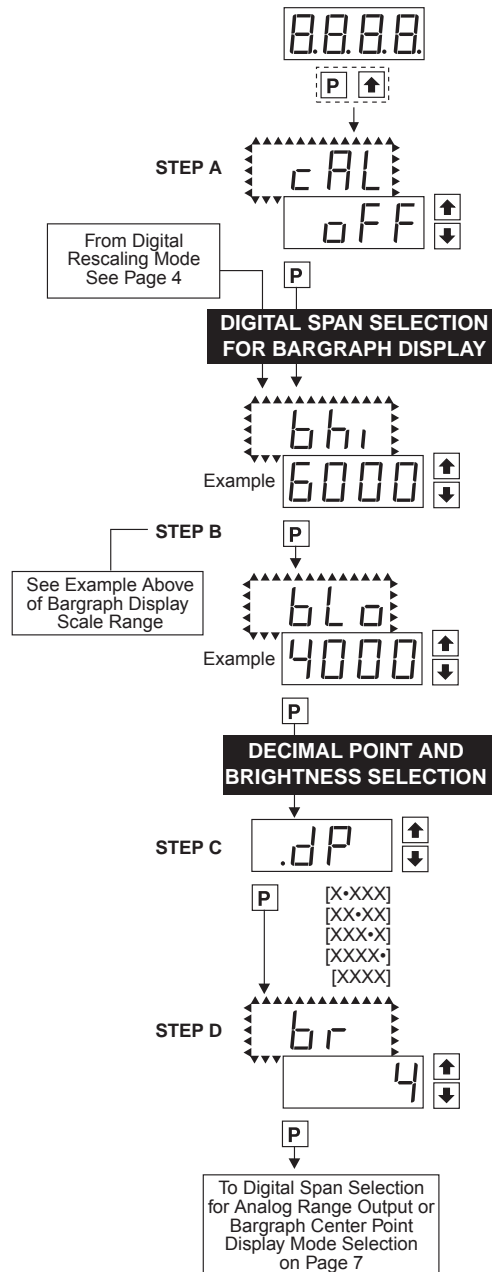

Decimal Point and Brightness Selection

STEP C Set the Decimal Point

- 1) Using the **[↑]** and **[↓]** buttons, adjust the display to the desired decimal point setting.
- 2) Press the **[P]** button. Display toggles between [br] and the previous brightness setting.

STEP D Set the Bargraph and Digital Display Brightness

- 1) Using the **[↑]** and **[↓]** buttons, adjust the display to the desired brightness setting (4 is the brightest setting).
- 2) Press the **[P]** button. Display toggles between [Anhi] and the previous [Anhi] setting.

Note: If at this point, the display skips directly to STEP G and toggles between [Cto] and [oFF], the software is detecting that the optional analog output hardware is NOT installed.

Digital Span Selection for Analog Range Output

STEP E Selecting the [AnHi] Digital Value for Analog High Output

- Using the \uparrow and \downarrow buttons, adjust the display to the desired digital value at which the [chi] Calibrated Analog High output will occur. For digital readings outside the digital span selected, the analog output will linearly rise above the value set for chi, up to the maximum analog output capability. However, the analog output will not go lower than the calibrated value set for cLo (see below).
- Press the \square button. Display toggles between [AnLo] and previous [AnLo] setting.

STEP F Selecting the [AnLo] Digital Value for Analog Low Output

- Using the \uparrow and \downarrow buttons, adjust the display to the desired digital value at which the [cLo] Calibrated Analog Low output will occur. For Digital readings outside the Digital Span selected, the analog output will not go lower than the calibrated value set for cLo.
- Press the \square button. The display toggles between [cto] and [oFF].

Note: Any two digital span points from -1999 to 9999 can be selected. The digital values for [AnHi] analog high and [AnLo] analog low can be reversed to provide a 20 to 4mA output. The digital span selected can be as small as two counts, when using the analog output to function as a Control or Alarm Driver. Small digital spans will cause the high resolution 16 bit D to A to increment digitally in stair case steps.

See Two Point Analog Output Range Setting and Calibration at the top of the next page.

Bargraph Center Point Display Mode Selection

Example of Using the Center Point Bargraph Display Mode with a Unipolar Input

If the meter's full scale range is set to 5000 counts, the midpoint would be 2500 counts. If a signal of 2500 counts is applied only one segment at the 2500 count mark will light up. If a signal of 4000 counts is applied the segments between the center segment (2500 counts) and the 4000 count mark light up.

If a signal of 1000 counts is applied, the segments between the center segment (2500 counts) and the 1000 count mark will light up.

Example of Using the Center Point Bargraph Display Mode with Bipolar Signal Inputs

The meter may also be calibrated to display symmetrical bipolar signals such as ± 1 V or ± 10 V. When the center point display mode is selected, it will then function as a center zero meter. When positive signals are applied, the bar will go up from the center point, and when negative signals are applied, the bar will go down from the center point.

STEP G Bargraph Center Point Mode Selection (See example above)

- To select bargraph center point mode, press the \uparrow or \downarrow button. Display changes from [oFF] to [on].
- Press the \square button. Display toggles between [diSP] and [on] or [oFF].

STEP H Digital Display ON/OFF Selection

- To set the display to [oFF], press the \uparrow or \downarrow button. Display toggles between [diSP] and [oFF].
- Press the \square button. The display exits the calibration mode and returns to the operational display. Only the bargraph display is on and the digital display is off.

If the digital display is selected to be off, pressing any button to make programming changes or to view setpoints activates the digital display. When the procedure is complete, the digital display will then automatically switch off.

The Display/Bargraph settings are now complete.

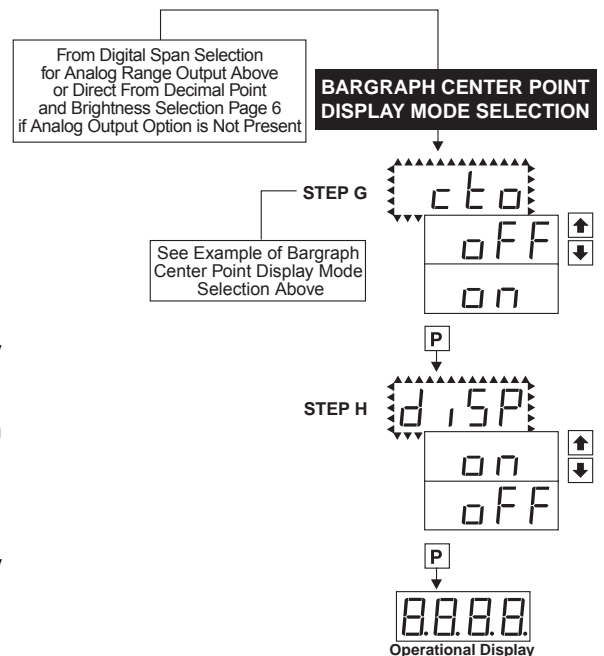
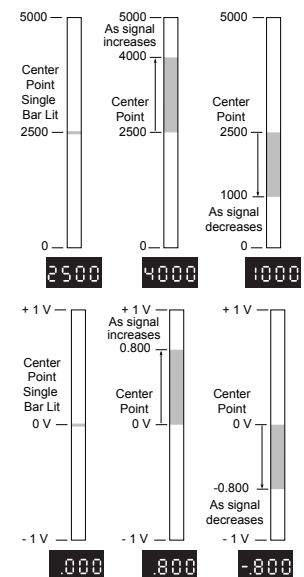
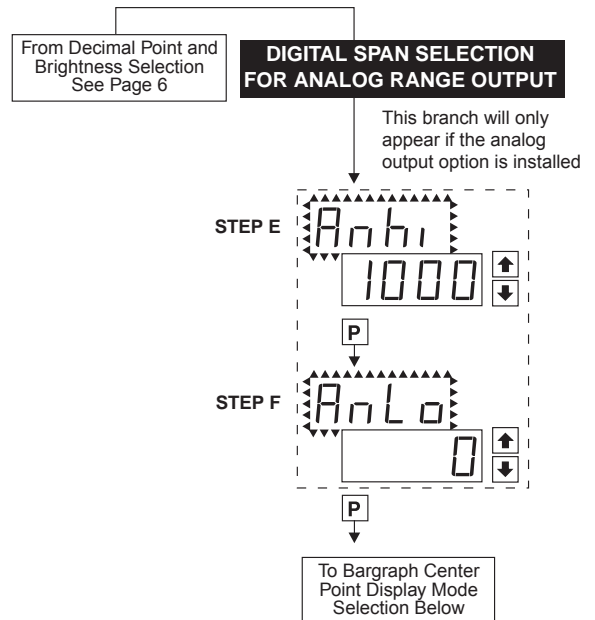

Two Point Analog Output Range Setting and Calibration

Determine if the Analog Output Selection Header is in the 4 to 20mA (0-20mA) position or the 0 to 10VDC position. If necessary, the module may have to be removed and the header position changed (see Component Layout below).

Note: Always disconnect power from the meter before removing the analog output module to adjust the mA or Volts output selection header and reinstalling it. When power is reconnected, the meter's software will automatically detect the presence or absence of the analog output module.

STEP A Enter the Calibration Mode

- 1) Press the [P] and [↑] buttons at the same time. Display toggles between [cAL] and [oFF].
- 2) Press the [↓] or [↑] button. Display changes from [oFF] to [on].
- 3) Press the [P] button. Display toggles between [cAL] and [ouT] input calibration.

Note: If at this point the display skips directly to toggle between Zero and the previous Zero setting, the software is detecting that the optional analog output hardware is NOT installed.

STEP B Enter the Two Point Analog [ouT] Output Range Setting and Calibration Mode

- 1) Press the [P] button. Display toggles between [cLo] and an internal scale factor.

STEP E Set or Calibrate [cLo] the Low Analog Value of the Analog Output Range

- 1) Connect a multimeter to analog output pins 17 and 18 (see Rear Panel Pinouts on page 11). Using the [↑] and [↓] buttons, adjust the analog output to the desired low value as measured on the multimeter. cLo may be adjusted to any value from -0.3 mA to 18 mA (mA output selected) or from -0.6 V to 8 V (volt output selected). However, the output of cLo must always be less than the value selected for chi. If a reversed analog output is desired, the values selected to establish the Digital Span can be reversed (see top of page 7). For digital readings outside the Digital Span selected, the analog output will not go any lower than the calibrated value set for cLo. However, the analog output will linearly rise above the value set for chi, up to the maximum analog output capability (see chi below).
- 2) Press the [P] button. Display toggles between [chi] and an internal scale factor.

STEP F Set or Calibrate [chi] the High Analog Value of the Analog Output Range

- 1) Using the [↑] and [↓] buttons, adjust the analog output to the desired high value as measured on the multimeter display. chi may be adjusted to any value from 18 mA to 24 mA (mA output) or from 8 V to 10.3 V (volt output). However, the value must be higher than the value selected for cLo. For digital readings outside the Digital Span selected, the analog output will linearly rise above the value set for chi, up to the maximum analog output capability.
- 2) Press the [P] button. The meter exits the calibration mode and returns to the operational display.

Note: The analog output range established by the values selected for cLo and chi will occur, automatically scaled, between the two digital values selected for AnHi and AnLo. However, the analog output can linearly rise above the chi value set for digital readings outside the digital span selected. See Digital Span Selection on page 7.

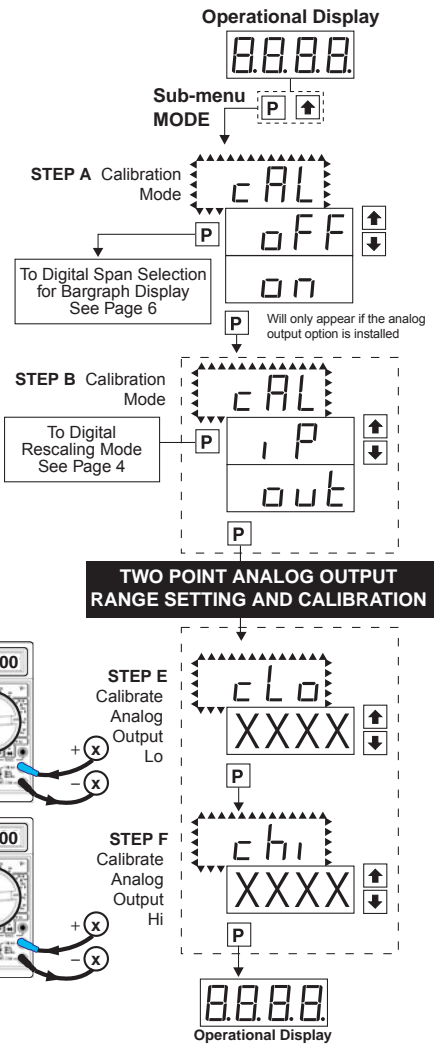

Case Dimensions

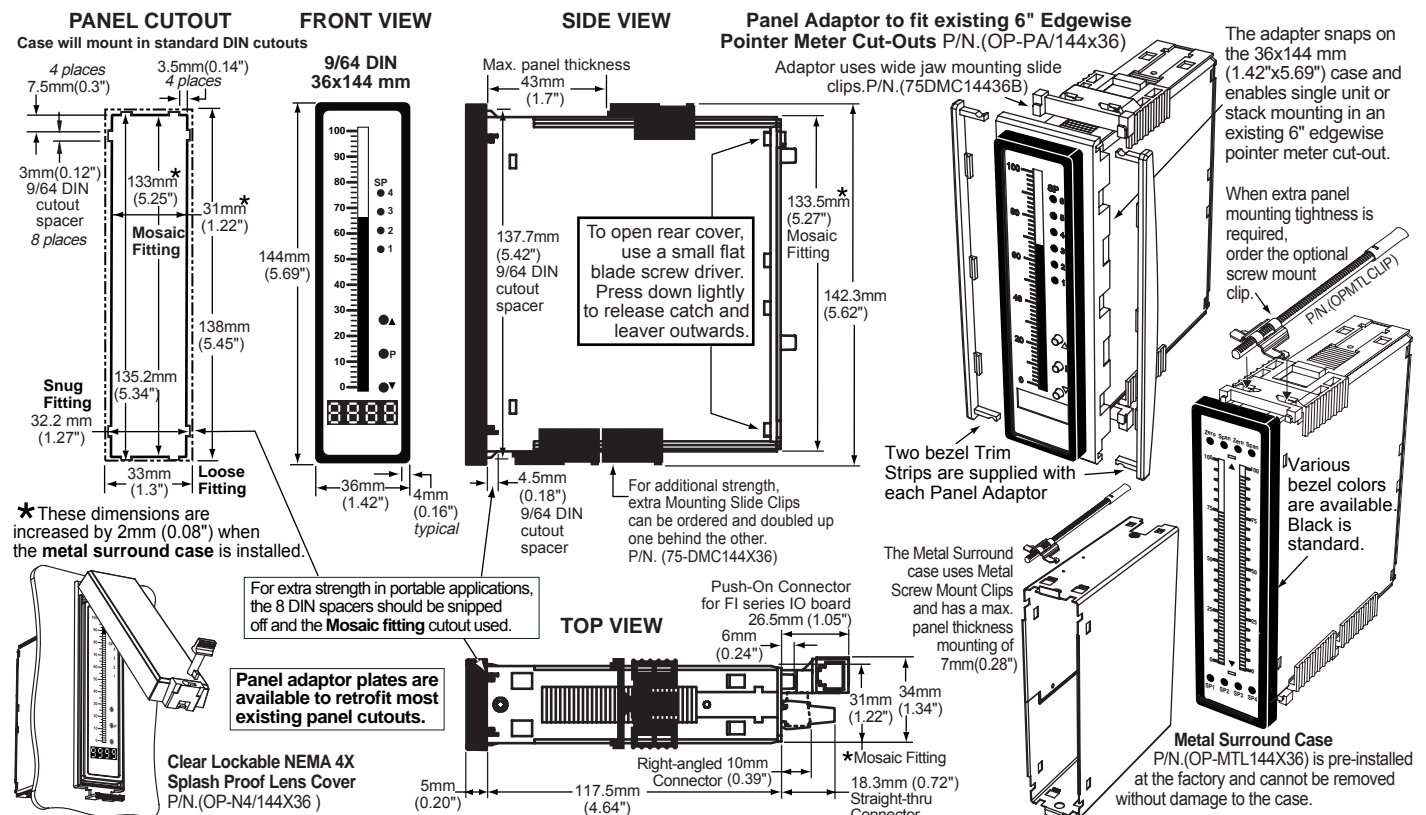

Setpoint Setting and Relay Configuration Mode

The following programming steps are required to enter the setpoint values and configure the relay functions in a meter with four relays using four setpoints. Generally if less than four relays are installed, the setpoints without relays are operational in software for tri-color control or display only purposes. To remove unwanted setpoint indications, set them to 9999 or -1999 depending on the relay activation mode selected.

STEP A Enter the Setpoint Mode

- 1) Press the and buttons at the same time. Display toggles between [SP1] and the previous SP1 setting.

STEP B Set Setpoint 1 [SP1]

- 1) Using the and buttons, adjust the display to the desired SP1 value.
- 2) Press the button. Display toggles between [doM] and the previous [doM] setting.

STEP C Set the SP1 Delay-on-Make [doM] Delay Time Setting

- 1) Using the and buttons, adjust the display to the desired [doM] value (0 to 9999 seconds). The reading must continuously remain in an alarm condition until this delay time has elapsed before the relay will make contact (energize).
- 2) Press the button. Display toggles between [dob] and the previous [dob] setting.

STEP D Set the SP1 Delay-on-Break [dob] Delay Time Setting

- 1) Using the and buttons, adjust the display to the desired [dob] value (0 to 9999 seconds). The reading must continuously remain in a non-alarm condition until this delay time has elapsed before the relay will break contact (de-energize).
- 2) Press the button. Display toggles between [hYSt] and the previous [hYSt] setting.

STEP E Select the Hysteresis [hYSt]

- 1) Using the and buttons, select the Hysteresis to be ON or OFF.
- 2) Press the button. Display toggles between PUM and (on) or (oFF).

STEP F Select Pump [PUM] (on) or (oFF)

- 1) Using the and buttons, select the Pump to be ON or OFF. When PUM is selected ON, and SP2 is set at a value higher than SP1, the SP1 relay will operate in a special "pump on pump off" mode. SP2 acts as the upper limit and SP1 acts as the lower limit of the Hysteresis Band on the SP1 relay.

For filling applications:

[rLYS] should be set to [LhXX] (see step M). The SP1 relay and SP1 LED Annunciator will then activate for inputs less than the SP1 setpoint, and remain ON until the SP2 setpoint is reached.

For emptying applications:

[rLYS] should be set to [hhXX] (see step M). The SP1 relay and SP1 LED Annunciator will then activate for inputs greater than the SP2 setpoint, and remain ON until the SP1 setpoint is reached.

- 2) Press the button. Display toggles between [SP2] and the previous SP2 setting.

STEP G Set Setpoint 2 (SP2)

- 1) Using the and buttons, adjust the display to the desired SP2 value.
- 2) Press the button. Display toggles between [hySt] and the previous [hySt] setting.

STEP H Select the Hysteresis [hYSt]

- 1) Using the and buttons, select the Hysteresis to be ON or OFF.
- 2) Press the button. Display toggles between [SP3] and the previous [SP3] setting.

STEP I Set Setpoint 3 (SP3) (No [doM] or [dob])

- 1) Using the and buttons, adjust the display to the desired SP3 value.
- 2) Press the button. Display toggles between [hySt] and the previous [hySt] setting.

STEP J Select the Hysteresis [hYSt]

- 1) Using the and buttons, select the Hysteresis to be ON or OFF.
- 2) Press the button. Display toggles between [SP4] and the previous [SP4] setting.

STEP K Set Setpoint 4 (SP4) (No [doM] or [dob])

- 1) Using the and buttons, adjust the display to the desired SP4 value.
- 2) Press the button. Display toggles between [hySt] and the previous [hySt] setting.

STEP L Select the Hysteresis [hYSt]

- 1) Using the and buttons, select the Hysteresis to be ON or OFF.
- 2) Press the button. Display toggles between [rLYS] and the previous relay setting.

Please Continue On Next Page.

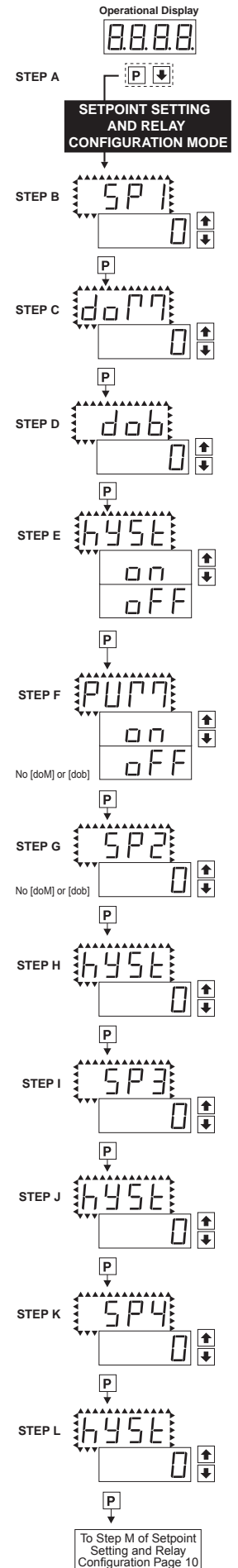

Setpoint Setting and Relay Configuration Mode Continued

STEP M Set Relay Activation mode [rLYS] for SP1

(h) High the relay energizes when the setpoint is exceeded. (L) Low the relay energizes below the setpoint. The setpoint is indicated from left to right SP1, SP2, SP3, SP4.

- Using the and buttons, select (L) or (h) for the first digit, which corresponds to SP1.
- Press the button. The SP2 Relay Activation digit begins to flash, and its decimal point is lit.

STEP N Set High (h) or Low (L) for SP2

- Using the and buttons, select (L) or (h) for the second digit, which corresponds to SP2.
- Press the button. The SP3 Relay Activation digit begins to flash, and its decimal point is lit.

STEP O Set High (h) or Low (L) for SP3

- Using the and buttons, select (L) or (h) for the third digit, which corresponds to SP3.
- Press the button. The SP4 Relay Activation digit begins to flash, and its decimal point is lit.

STEP P Set High (h) or Low (L) for SP4

- Using the and buttons, select (L) or (h) for the fourth digit, which corresponds to SP4.
- Press the button.

If a mono-color red or green display is installed then the Setpoint Relay Programming Mode is now complete and the meter returns to the operational display.

If a tricolor bargraph display is installed then the Bargraph Color Programming Mode will be entered and display toggles between [CoL] and the previous setting. Color selection menu will be displayed.

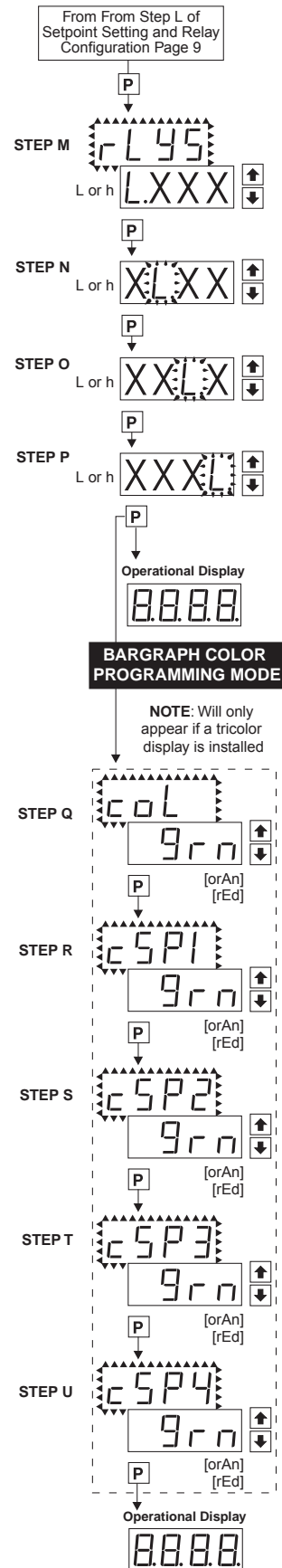

Bargraph Color Programming Mode

To comply with the latest safety requirements, the tri-color bargraph is designed like a traffic light, to display either red, orange or green, but only one color at a time. When the bar reaches a selected color change point, the entire bar will change to the color designated for that zone. This eliminates any ambiguity as to the signal status, especially just after transitioning to a new zone.

First (Step Q) is to select the color to be displayed, when the bar is “below*”, whichever set point is set to the lowest position.

Second (Steps R, S, T, and U) is to select the color to be displayed when the bar is above each specific set point, regardless of the order or position to which the set points are set.

However, if two or more setpoints with differently specified colors are positioned at the same set point value, the color specified for the set point with the highest identifying number will be displayed. When set points are set to the same value, the SP4 color overrides the SP3 color, the SP3 color overrides the SP2 color, and the SP2 color overrides the SP1 color.

STEP Q Select Bargraph Color when the bar is BELOW* the Setpoint that is set to the lowest position

- Using the and buttons, select the desired bargraph color [grn], [oran] or [red]
- Press the button. Display toggles between [CSP1] and the previous color setting.

STEP R Select Bargraph Color when the bar is ABOVE* SP1 Setpoint

- Using the and buttons, select the desired bargraph color [grn], [oran] or [red]
- Press the button. Display toggles between [CSP2] and the previous color setting.

STEP S Select Bargraph Color when the bar is ABOVE* SP2 Setpoint

- Using the and buttons, select the desired bargraph color [grn], [oran] or [red]
- Press the button. Display toggles between [CSP3] and the previous color setting.

STEP T Select Bargraph Color when the bar is ABOVE* SP3 Setpoint

- Using the and buttons, select the desired bargraph color [grn], [oran] or [red]
- Press the button. Display toggles between [CSP4] and the previous color setting.

STEP U Select Bargraph Color when the bar is ABOVE* SP4 Setpoint

- Using the and buttons, select the desired bargraph color [grn], [oran] or [red]
- Press the button. The meter exits the setpoint mode and returns to the operational display.

The Bargraph Color programming mode is now complete.

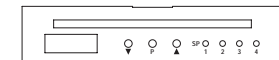

Note: For horizontal display formats BELOW should be read as, “to the left” and ABOVE* should be read as, “to the right”.

Functional Diagram

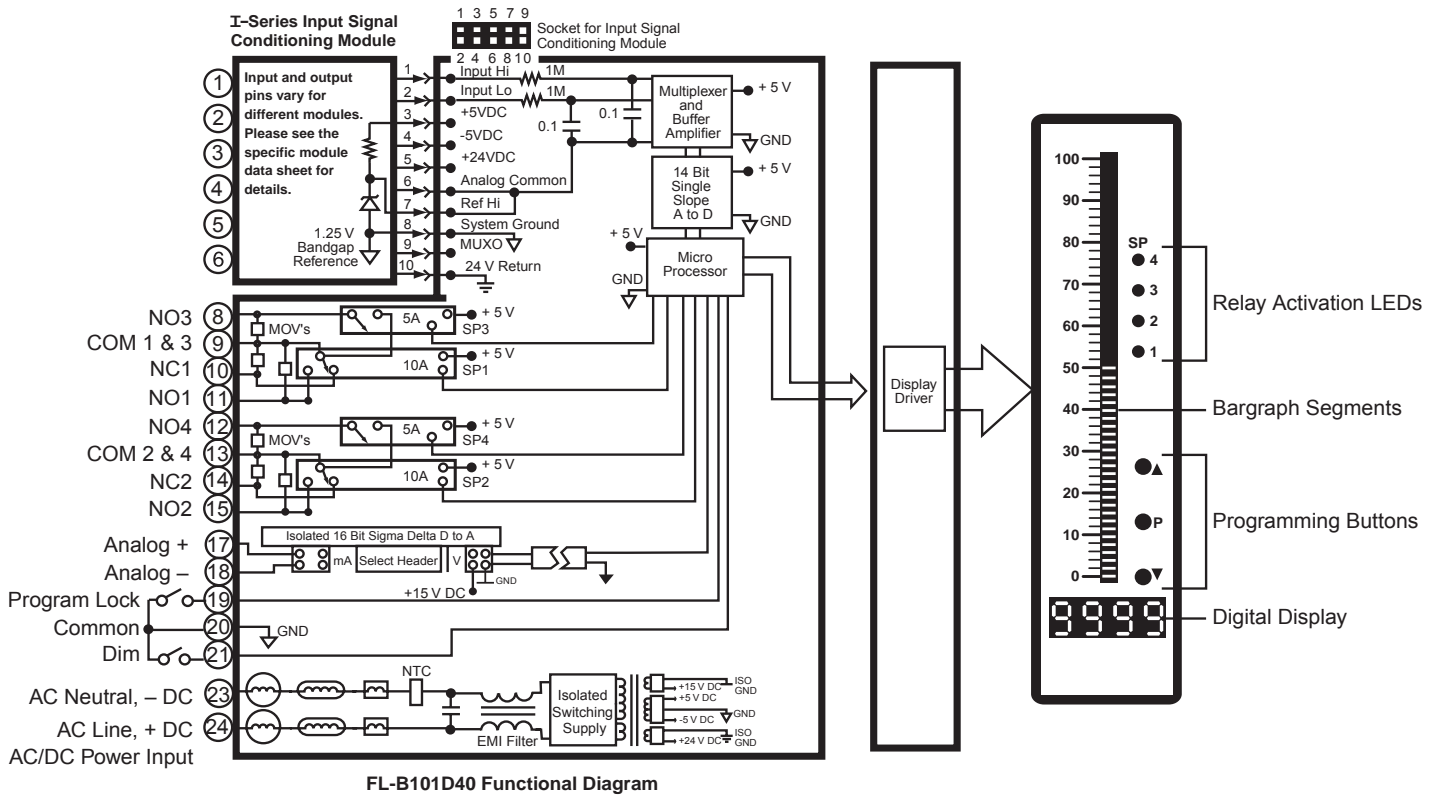

Connector Pinouts

This meter uses plug-in type screw terminal connectors for all input and output connections. The power supply connections (pins 23 and 24) have a unique plug and socket outline to prevent cross connection. The main board uses standard right-angled connectors.

Replacement 2-, 3-, and 4-pin plug connectors are available (see Accessories on page 20).



WARNING: AC and DC input signals and power supply voltages can be hazardous. Do Not connect live wires to screw terminal plugs, and do not insert, remove or handle screw terminal plugs with live wires connected.

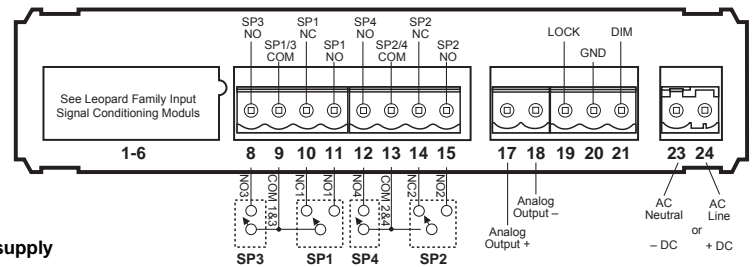

Note: The sequence of setpoint outputs on meters shipped prior to 2002 was 1-2-3-4. The sequence is now 3-1-4-2, enabling delay on make (dom) and delay on break (dob) to be used with both Form "C" relays.

Pin Descriptions

Input Signal – Pins 1 to 6

Pins 1 to 6 are reserved for the input signal conditioner. See the data sheet for the selected input signal conditioner.

Pins 8 to 15 – Relay Output Pins

- Pin 8** SP3 NO. Normally Open 5 Amp Form A.
- Pin 9** SP1/3 COM. Common for SP1 and SP3.
- Pin 10** SP1 NC. Normally Closed 10 Amp Form C.
- Pin 11** SP1 NO. Normally Open 10 Amp Form C.
- Pin 12** SP4 NO. Normally Open 5 Amp Form A.
- Pin 13** SP2/4 COM. Common for SP2 and SP4.
- Pin 14** SP2 NC. Normally Closed 10 Amp Form C.
- Pin 15** SP2 NO. Normally Open 10 Amp Form C.

Pins 17 to 21 – Rear Panel Switches

- Pin 17** ANALOG OUTPUT (+). mA (0 to 20 mA/4 to 20 mA) or V (0 to 10 V) output is header selectable.

- Pin 18** ANALOG OUTPUT (-). mA (0 to 20 mA/4 to 20 mA) or V (0 to 10 V) output is header selectable.
- Pin 19** Programming LOCK. By connecting the LOCK pin to the COMMON pin, the meter's programmed parameters can be viewed but not changed.
- Pin 20** COMMON. To activate the LOCK or DIM functions from the rear of the meter, the respective pins have to be connected to the COMMON pin. This pin is connected to the internal power supply ground.
- Pin 21** DIM. By connecting the display dim (DIM) pin to the COMMON pin, the display brightness setting is halved.

Pins 23 and 24 – AC/DC Power Input

Auto-sensing AC/DC power supply. For voltages between 85-265 V AC / 95-370 V DC (PS1) or 18-48 V AC / 10-72 V DC (PS2).

- Pin 23** AC Neutral / -DC. Neutral power supply line.
- Pin 24** AC line / +DC. Live power supply line.

Component Layout

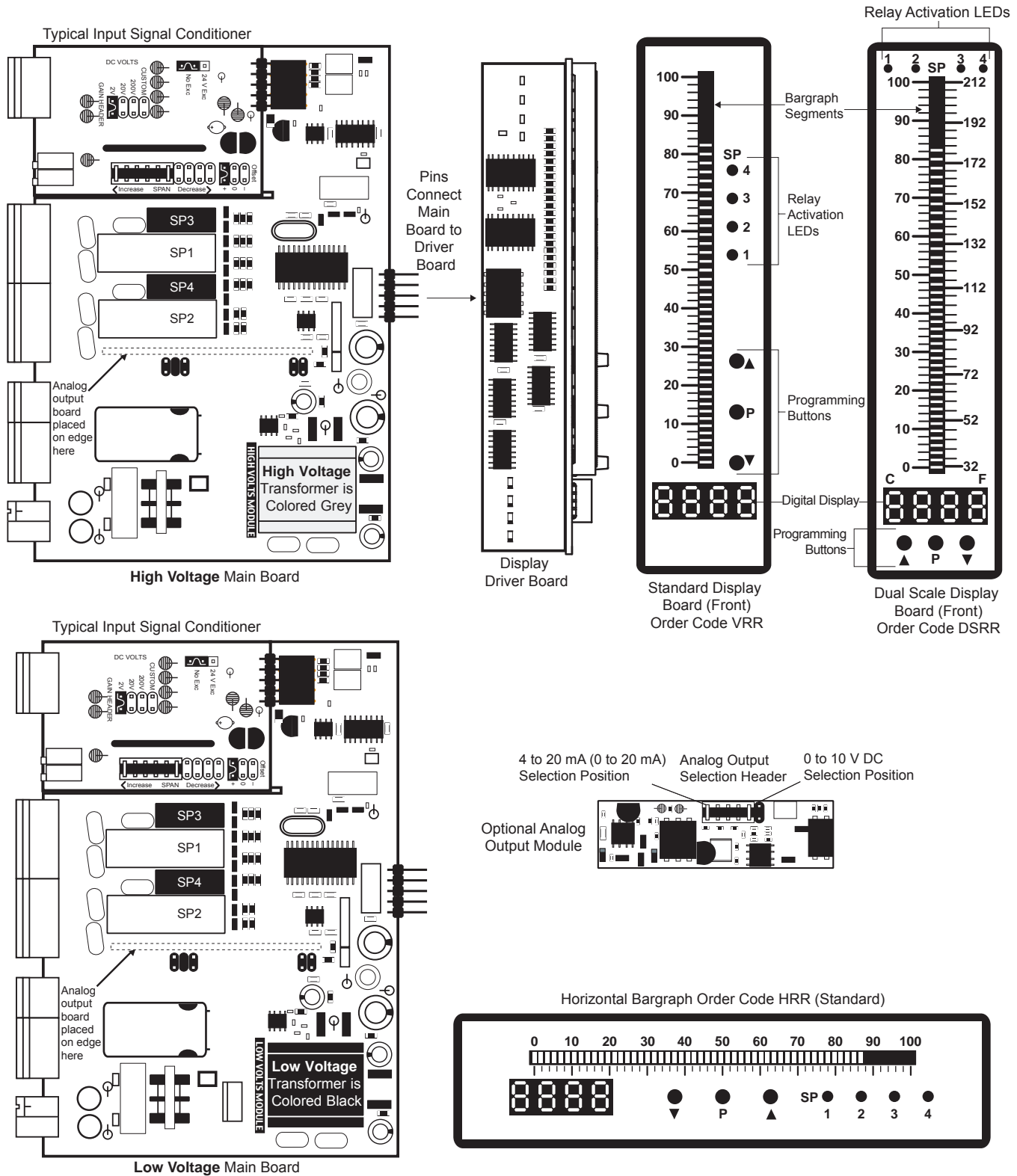

Connectors

WARNING



AC and DC input signals and power supply voltages can be hazardous. Do Not connect live wires to terminal blocks, and do not insert, remove or handle terminal blocks with live wires connected.

Standard plug-in screw terminal blocks provided by Texmate:

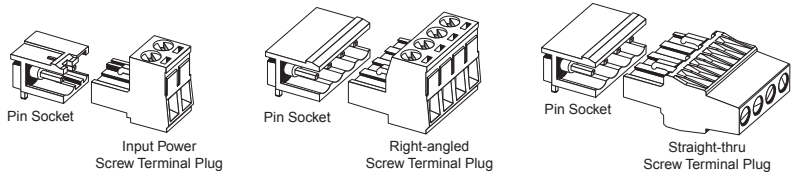









I-Series Input Signal Conditioning Modules

Many additional input modules are available and others are constantly being developed. Check with your local distributor or www.texmate.com for updated information.

Pre-calibrated **I-Series** input modules, that have span or zero potentiometers, can be interchanged between any **I-Series** compatible meter, without recalibration, because all of the analog scaling and reference circuitry is self-contained within the module. Where appropriate, all the standard ranges shown are designed to be header selectable by the user, and Texmate's unique SPAN ADJUST Header facilitates scaling to almost any required engineering unit. See Input Module Component Glossary and Calibration on pages 16-17.

Unless otherwise specified Texmate will ship all modules pre-calibrated with factory preselected ranges and/or scalings as shown in **BOLD** type. Other pre-calibrated standard ranges or custom ranges may be ordered. Factory installed custom scaling and other custom options are also available (see Ordering Information, Special Options on last page).

Symbols Indicate Module Compatibility Within Meter Families		
 TIGER Family	 LEOPARD Family	 LYNX Family
 LEOPARD Family	 LYNX Family	 TIGER Family
 LYNX Family	 TIGER Family	 LEOPARD Family
ALL MODELS	SOME MODELS	MODEL SPECIFIC



WARNING: AC and DC input signals and power supply voltages can be hazardous. Do Not insert, remove or handle modules with live wires connected to any terminal plugs.

IA01: AC Volts Scaled RMS, 200/600V AC

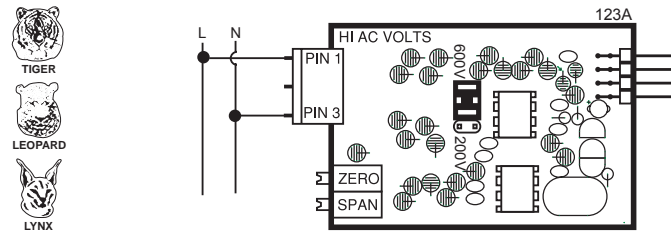

IA06: AC Volts True RMS, 300/600V AC

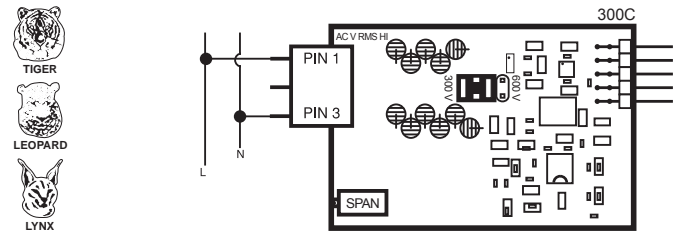

IA02: AC Volts Scaled RMS, 200mV/2V/20V AC

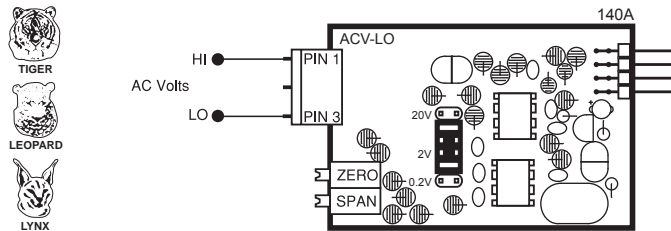

IA07: AC Volts True RMS, 200mV/2V/20V AC

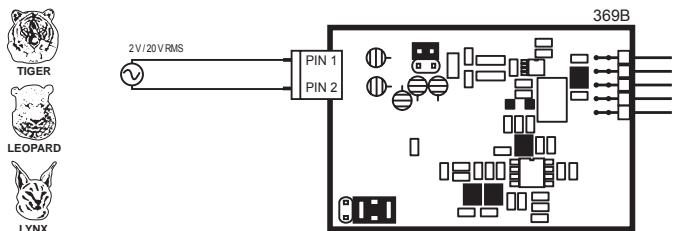

IA03: AC Milliamps Scaled RMS, 2/20/200mA AC

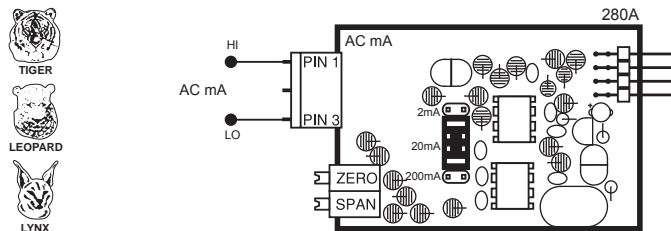

IA08: AC Milliamps True RMS, 2/20/200mA AC

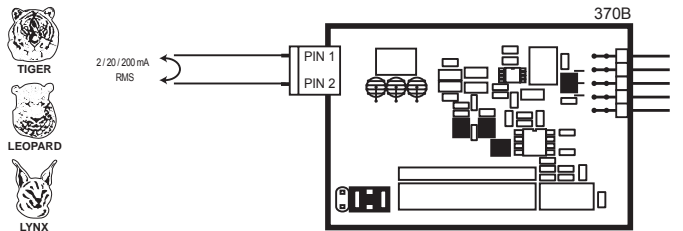

IA04: AC Amps Scaled RMS, 1 Amp AC

IA05: AC Amps Scaled RMS, 5 Amp AC

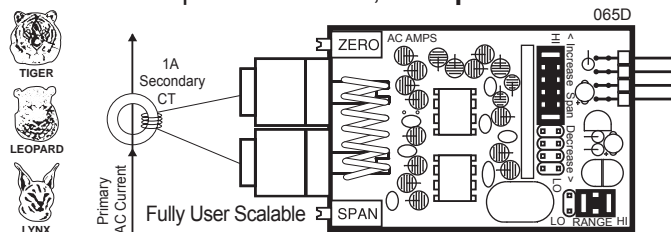

IA09: AC Amps True RMS, 1 Amp AC

IA11: AC Amps True RMS, 5 Amp AC

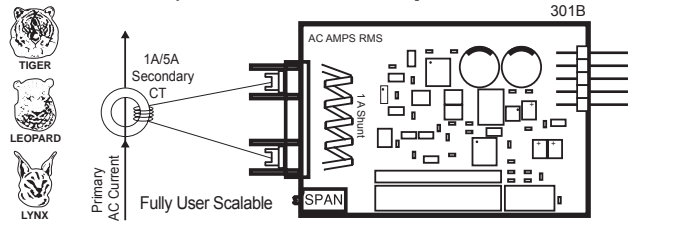

I-Series Input Signal Conditioning Modules

IA10 AC Millivolts, Scaled RMS, 100mV AC

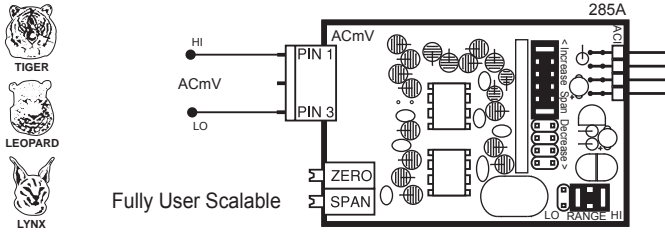

ID05: DC Volts 2/20/200/Custom V DC with Offset and 24V Exc.

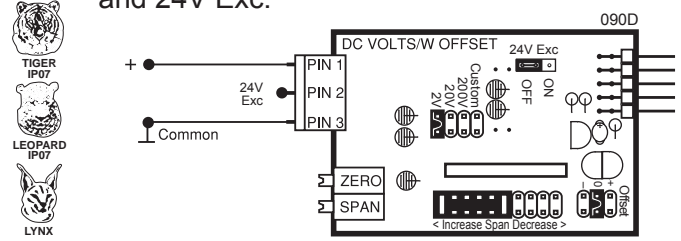

IA12: AC Millivolt RMS Sigma Delta

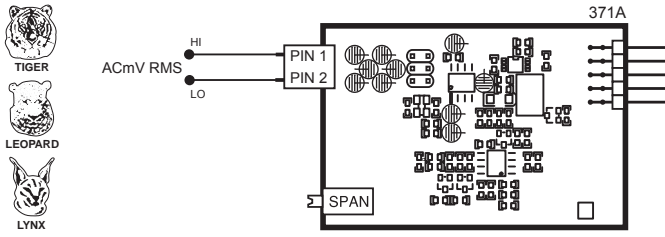

ID07: DC Milliamps, 2/20/200mA DC with Offset and 24V Exc

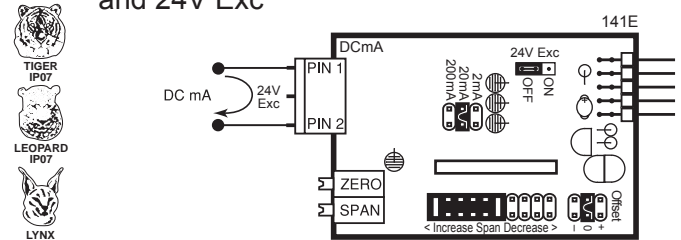

ID01: DC Volts, 2/20/200V/Custom w/24V DC Exc

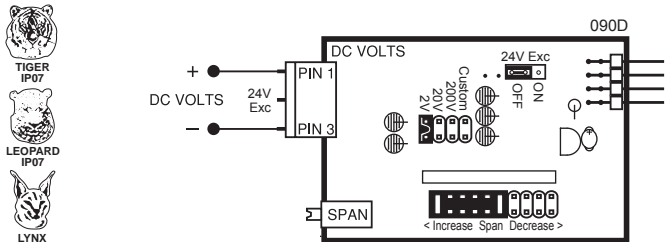

IGYZ: Universal Direct Pressure (Absolute or Differential/Gage) See below for ordering code options

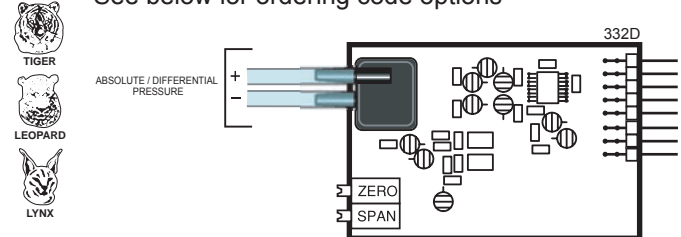

ID02: DC Millivolts, 20/50/100/200mV DC w/24V DC Exc

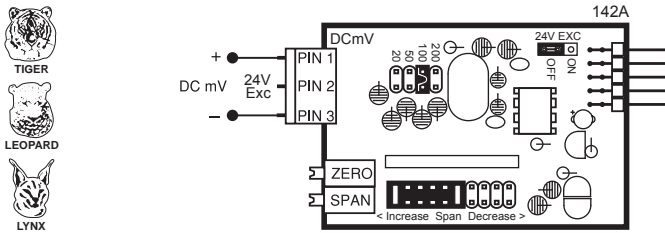

Ordering Code Options for Direct Pressure (IGYX, IGYZ & IGYZ)

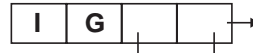

Sensor Range	CH1 Order Code	CH2 Order Code
1 psi Absolute	A	A
1 psi Differential	B	B
5 psi Absolute	C	C
5 psi Differential	D	D
15 psi Absolute	E	E
15 psi Differential	F	F
30 psi Absolute	G	G
30 psi Differential	H	H
100 psi Absolute	J	J
100 psi Differential	K	K

For Single Channel IGYX with two digital inputs, the last digit of order code is always X.

For Universal Direct Pressure IGYZ, the last digit of order code is always Z.

ID03: DC Milliamps, 2/20/200mA DC w/24V DC Exc

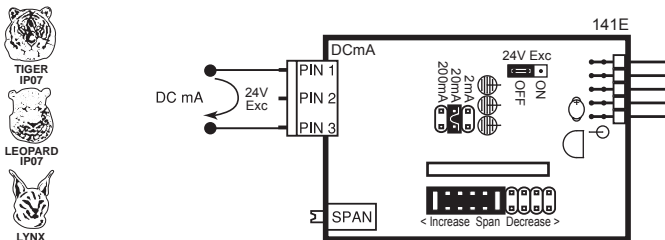

IP01: Process Loop, 4-20mA IP02: Process Loop, 4-20mA with 24VDC EXC

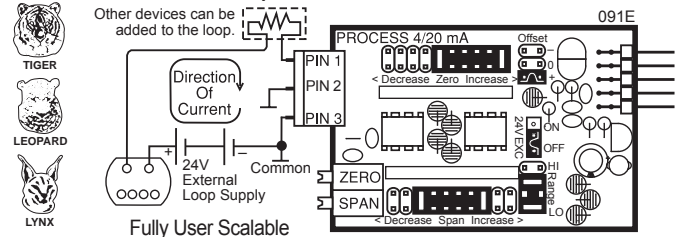

ID04: DC Amps, 5A DC ID09: DC Amps, 1A DC

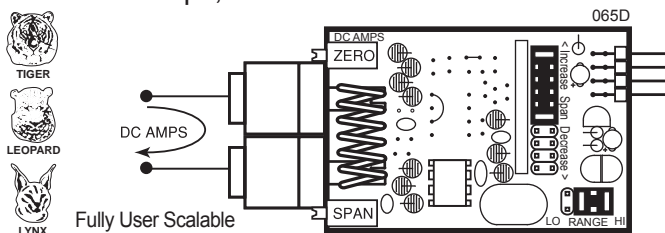

IP03: Process Input, 1-5V DC with Offset, 24V Exc

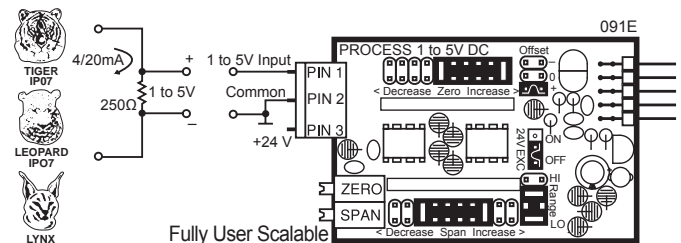

I-Series Input Signal Conditioning Modules

IP07: Universal Process Input
 2V/5V/10V/20V/200V/2mA/20mA/Custom

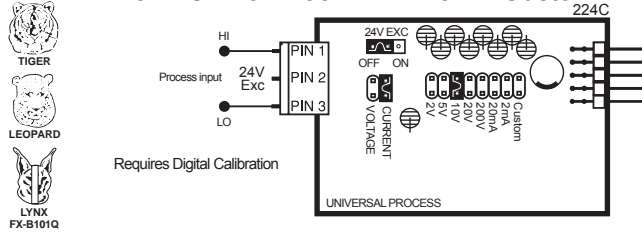

ISO4: Pressure/Load Cell Ext Exc., 20/2mV/V, 4/6-wire

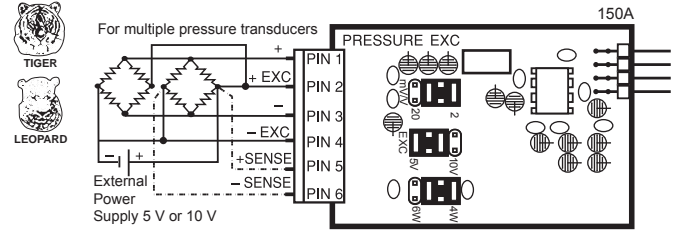

IPT1: Prototype Board for Custom Design

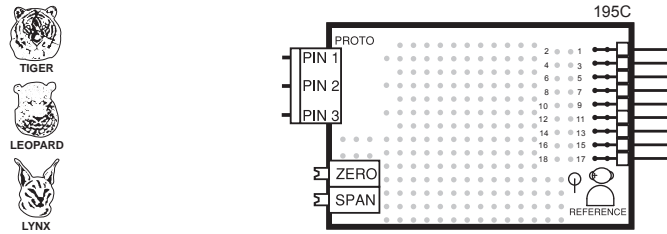

ISO5: Pressure/Load Cell 20/2mV/V, 5/10V Exc 4-wire

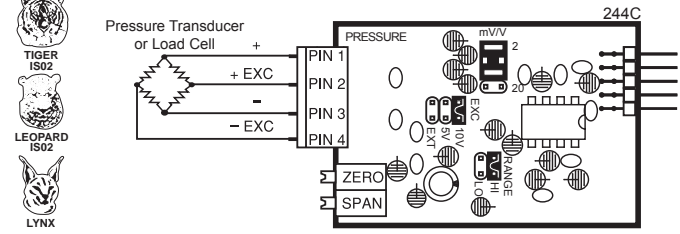

IR02: 3 wire Potentiometer 1KΩ min (0-FS.)

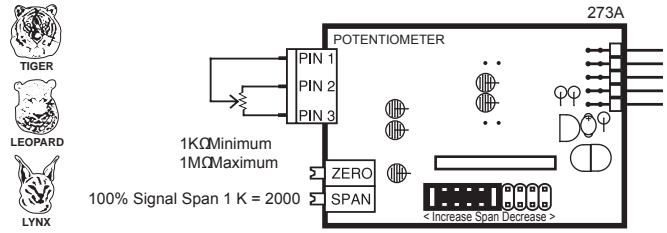

ISO6: Pressure/Load Cell Ext Exc., 20/2mV/V, 4-wire

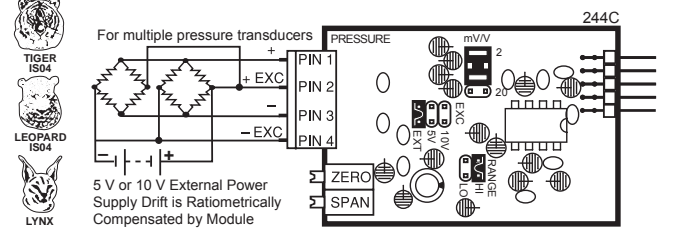

IR03: Linear Potentiometer 1KΩ min

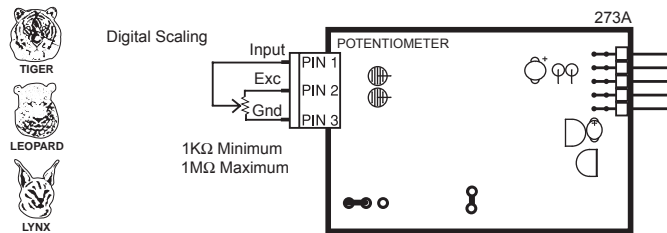

ISO7: Pressure/Load Cell Ext Exc. High Impedance, 20/2mV/V, 4/6-wire

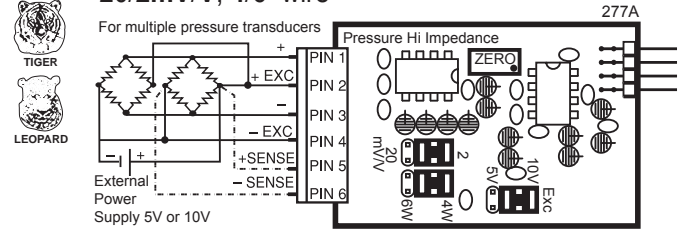

IR04: Resistance 2KΩ (Lynx only)

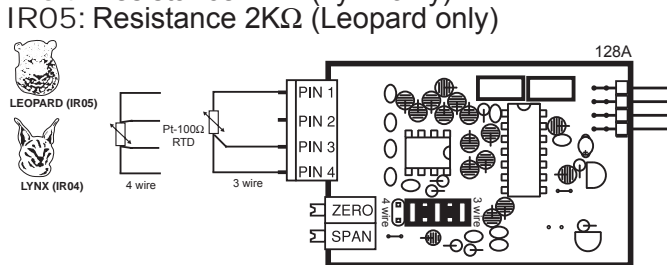

ISO1: Strain Gage 5/10VDC Exc., 20/2mV/V, 4/6-wire

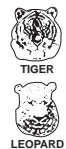
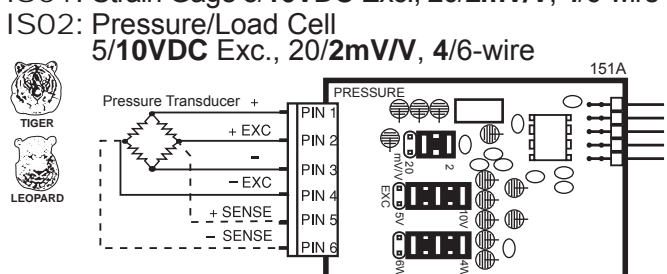

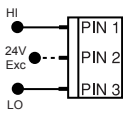

Input and Output Pins

On most modules Pin 1 is the Signal High input and Pin 3 is the Signal Low input. Typically Pin 2 is used for Excitation Voltage output.

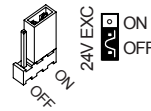

24V DC Output Header

On some modules this header enables a 24V DC 25mA (max) Excitation/Auxiliary output to be connected to Pin 2.

INPUT RANGE Header

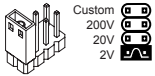

Range values are marked on the PCB. Typically two to four positions are provided, which are selected with either a single or multiple jumper clip. When provided, a custom range position is only functional when the option has been factory installed.

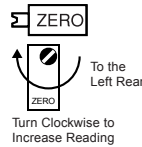

ZERO Potentiometer (Pot)

If provided, the ZERO pot is always to the left of the SPAN pot (as viewed from the rear of the meter). Typically it enables the input signal to be offset $\pm 5\%$ of full scale (-100 to +100 counts).

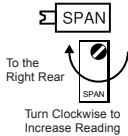

SPAN Potentiometer (Pot)

If provided, the 15 turn SPAN pot is always on the right side (as viewed from the rear of the meter). Typical adjustment is 20% of the input signal range.

SPAN ADJUST Header

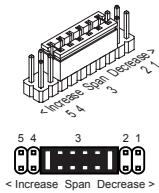

This unique five-position header expands the adjustment range of the SPAN pot into five equal 20% steps, across 100% of the input Signal Span. Any input Signal Span can then be precisely scaled down to provide any required Digital Display span from 1999 counts to 001 (one count).

SPAN Adjust Header position	1	2	3	4	5
SPAN Pot %	20%	20%	20%	20%	20%
Signal Span %	20%	40%	60%	80%	100%

Equivalent Circuit: Acts like 75 Turn 1 Megaohm Potentiometer

ZERO OFFSET RANGE Header

When provided, this three position header increases the ZERO pot's capability to offset the input signal, to $\pm 25\%$ of the digital display span. For example a Negative offset enables a 1 to 5V input to display 0 to full scale. The user can select negative offset, positive offset, or no offset (ZERO pot disabled for two step non-interactive span and offset calibration).

Zero Offset Range Header

Header Position	1	2	3
Offset Range	≈ -500 Counts	No Offset	$\approx +500$ Counts

Equivalent Circuit: 15 Turn Potentiometer

SPAN RANGE Header

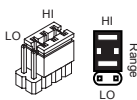

When this header is provided it works in conjunction with the SPAN ADJUST Header by splitting its adjustment range into a Hi and a Lo range. This has the effect of dividing the adjustment range of the SPAN pot into ten equal 10% steps across 100% of the input Signal Span.

SPAN Adjust Header position	1	2	3	4	5
SPAN Pot %	10%	10%	10%	10%	10%
Signal Span %	10%	20%	30%	40%	50%

SPAN Adjust Header position	1	2	3	4	5
SPAN Pot %	10%	10%	10%	10%	10%
Signal Span %	60%	70%	80%	90%	100%

Equivalent Circuit: Acts like a 150 Turn Potentiometer

ZERO ADJUST Header

When this header is provided, it works in conjunction with the ZERO OFFSET RANGE Header, and expands the ZERO pot's offset capability into five equal negative steps or five equal positive steps. This enables virtually any degree of input signal offset required to display any desired engineering unit of measure.

Zero Offset Range Header

ZERO Adjust Header position	5	4	3	2	1
ZERO Pot %	-20%	-20%	-20%	-20%	-20%
Offset Range	-1200 or more counts				

Header Position	1	2	3	4	5
Offset Range	$+1200$ or more counts				

Equivalent Circuit: 75 Turn Potentiometer

In addition to the analog calibration capabilities that enable many modules to be interchanged between different meters without loss of accuracy the Leopard Family of meters have enhanced Digital Calibration functions.

Basic standard range calibration of direct reading modules that utilize either Auto Zero or a ZERO pot, an INPUT RANGE Header and or a SPAN pot.

- 1 If the module has an INPUT RANGE Header, reposition the jumper clip to select the desired input signal range.
2. Apply a zero input or short the input pins. The display will auto zero, or if the module has a ZERO pot, it should be adjusted until the display reads zero.
- 3 Apply a known input signal that is at least 20% of the full scale input range and adjust the SPAN pot until the display reads the exact input value. For negative inputs, Leopard Family Meters will display negative overrange at 50% of full scale range.
- 4 Decimal Points. The selection or positioning of decimal points has no effect on the calibration of the modules

Wide range scaling, in engineering units not requiring offsets, with modules that utilize auto-zero or a ZERO pot, a SPAN RANGE Header and or a SPAN ADJUST Header.

Texmate's unique SPAN ADJUST and SPAN RANGE Headers provide the circuit equivalent of an ultra-precision one megohm 75 or 150 turn potentiometer that can infinitely scale down any Input Signal SPAN to provide any full scale Digital Display Span from 1999 (counts) to 001 (one count).

If the module has an INPUT RANGE Header, and the required full scale Digital Display Span (counts) is to be larger than the directly measured value of the input Signal Span, then the next lower range on the INPUT RANGE Header should be selected. The resulting over range Signal Span is then scaled down, by selecting the position of the SPAN RANGE Header and or the SPAN ADJUST Header, which will reduce the input Signal Span to a percentage, that the required Digital Display Span can be reached by calibration with the SPAN pot.

Example A: 0 to 10 V to read 0 to 1800 gallons.

Signal Span = 10V, Digital Display Span = 1800 counts

- 1 Select the 2 V INPUT RANGE Header position. This will provide a digital display of 1800 counts with an input of only 1.8 V which is $(1.8 \div 10) = 18\%$ of the examples 10 V Signal Span.
- 2 To scale down the Signal Span to 18% select the 20% Signal Span position on the SPAN ADJUST Header (position 1) or if the module has a SPAN RANGE Header, select (LO Range) and 20% Signal Span position on the SPAN ADJUST Header (position 2).
- 3 Apply a zero input or short the input pins. The display will auto zero, or if the module has a ZERO pot, it should be adjusted until the display reads zero.
- 4 Apply 10 V and adjust the SPAN pot until the display reads 1800.

Large offset scaling and calibration of process signal inputs with modules that utilize ZERO ADJUST Headers and or ZERO OFFSET RANGE Headers.

Texmate's unique ZERO OFFSET RANGE Header enables the use of a simple two step scaling and calibration procedure for those process signals that require large offsets. This eliminates the back and forth interaction, between zero and span settings, that is often required to calibrate less finely engineered products.

The first step is to set the ZERO OFFSET RANGE Header to the center position (No Offset) and scale down the Input Signal Span to a percentage that will enable calibration with the SPAN pot to reach the required Digital Display Span.

The second step is to set the ZERO ADJUST and or ZERO OFFSET RANGE Header to provide a positive or negative offset of sufficient counts that calibration with the ZERO pot will offset the Digital Display Span to produce the required digital reading.

Example B: 1 to 5 V to read -100 to 1500 °C.

Signal Span = 4V, Digital Display Span = 1600 counts

- 1 If the module has an INPUT RANGE Header the 2 V position should be selected. This will provide a digital display of 1600 counts for an input of 1.6 V which is $(1.6 \div 4) = 40\%$ of the examples 4 V signal span. To scale down the Signal Span to 40% select the 40% Signal Span position on the SPAN ADJUST Header (position 2).
- 2 If the module is a Process Input 1-5 V DC type, select the (Hi Range) position on the SPAN RANGE Header and the 100% Signal Span position on the SPAN ADJUST Header (position 5, max increase). This will provide a digital display of 1600 counts for an input of 4V which is 100% of the examples 4V Signal Span.
- 3 Set the ZERO OFFSET RANGE Header to the center position (no offset). Apply 1 V and adjust the SPAN pot until the display reads 400 . A 4V input would then read 1600 counts.
- 4 Set the ZERO OFFSET RANGE Header to the negative offset position. If the module has a ZERO ADJUST Header select the position that will provide a negative offset of ≈ -500 counts. Apply 1 V and adjust the ZERO pot until the display reads -100. Apply 5 V and check that the display reads 1500.

Example C: 4 to 20 mA to read 00.0 to +100.0%

Signal Span = 16 mA, Digital Display Span = 1000 counts.

- 1 The full scale Signal Span of the Process Input 4-20 mA modules is 0 to 20 mA for a full scale Digital Display Span of 0 to 2000 counts. This will provide a digital display of 1000 counts with an input of only 10 mA which is $(10 \div 16) = 62.5\%$ of the examples 16 mA signal span.
- 2 To scale down the Signal Span to 62.5% select the (Hi Range) Position on the Span Range Header and the 70% Signal Span position on the SPAN ADJUST Header (position 2).
- 3 Set the ZERO OFFSET RANGE Header to the center position (no offset). Apply 4 mA and adjust the SPAN pot until the display reads 250 . A 16 mA input would then read 1000 counts.
- 4 Set the ZERO OFFSET RANGE Header to the positive offset position. If the module has a ZERO ADJUST Header select the position that will provide a negative offset of ≈ -250 counts. Apply 4 mA and adjust the ZERO pot until the display reads 000. Apply 20 mA and check that the display reads 1000.

Ordering Information

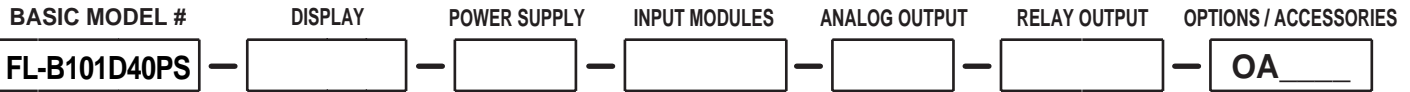

Add to the basic model number the order code suffix for each standard option required. The last suffix is to indicate how many different special options and or accessories that you may require to be included with this product.

Ordering Example: FL-B101D40PS-VRR-PS1-IA01-OIC-R11-OA2 plus CR-CHANGE and an OP-N4/144X36

► BASIC MODEL NUMBER

FL-B101D40PS . . . 144x36mm, 101 Segment Bargraph, 4 Digit, PSF

Standard Options for this Model Number

Order Code Suffix Description

► DISPLAY

VRR . . . Red LED Bargraph w/4 Digit Red DPM, Vertical
VGG . . . Green LED Bargraph w/4 Digit Green DPM, Vertical
VGR . . . Green LED Bargraph w/4 Digit Red DPM, Vertical
VRG . . . Red LED Bargraph w/4 Digit Green DPM, Vertical
VTG . . . Tri-Color Bargraph w/4 Digit Green DPM, Vertical
VTR . . . Tri-Color Bargraph w/4 Digit Red DPM, Vertical

HRR . . . Red LED Bargraph w/4 Digit Red DPM, Horizontal
HGG . . . Green LED Bargraph w/4 Digit Green DPM, Horizontal
HGR . . . Green LED Bargraph w/4 Digit Red DPM, Horizontal
HRG . . . Red LED Bargraph w/4 Digit Green DPM, Horizontal
HTG . . . Tri-Color Bargraph w/4 Digit Green DPM, Horizontal
HTR . . . Tri-Color Bargraph w/4 Digit Red DPM, Horizontal

DSGG . . . Dual Scale Green LED Vertical Bargraph w/4 Digit Green DPM
DSGR . . . Dual Scale Green LED Vertical Bargraph w/4 Digit Red DPM
DSRG . . . Dual Scale Red LED Vertical Bargraph w/4 Digit Green DPM
DSRR . . . Dual Scale Red LED Vertical Bargraph w/4 Digit Red DPM
DSTG . . . Dual Scale Tri-Color Vertical Bargraph w/4 Digit Green DPM
DSTR . . . Dual Scale Tri-Color Vertical Bargraph w/4 Digit Red DPM

► POWER SUPPLY

PS1 . . . 85-265VAC/95-370VDC
PS2 . . . 15-48VAC/10-72VDC

► INPUT MODULES (Partial List. See www.texmate.com)

Unless otherwise specified Texmate will ship all modules precalibrated with factory preselected ranges and/or scalings as shown in **BOLD** type.

IA01 . . . AC-Volts Scaled RMS, 200/**600V AC**
IA02 . . . AC-Volts Scaled RMS, 200mV/**2V/20V AC**
IA03 . . . AC-mA Scaled RMS, **2/20/200mA AC**
IA04 . . . AC-Amps Scaled RMS, **0-1 Amp AC (0-100.00)**
IA05 . . . AC-Amps Scaled RMS, **0-5 Amp AC (0-100.00)**
IA06 . . . AC-Volts True RMS, 200/**600V AC**
IA07 . . . AC-Volts True RMS, 200mV/**2V/20V AC**
IA08 . . . AC-mA True RMS, **2/20/200mA AC**
IA09 . . . AC-Amps True RMS, **0-1 Amp AC (0-100.00)**
IA10 . . . AC-Millivolt, Scaled RMS, **100mV AC**
IA11 . . . AC-Amps True RMS, **0-5 Amp AC (0-100.00)**
IA12 . . . AC-Millivolt, True RMS, **100mV AC**
ID01 . . . DC-Volts, **2/20/200V/Custom** w/24V DC Exc
ID02 . . . DC-Millivolt, 20/50/**100/200mV DC** w/24V DC Exc
ID03 . . . DC-Milliamper, **2/20/200mA DC** w/24V DC Exc
ID04 . . . DC-Amps, **5A DC**
ID05 . . . DC-Volts **2/20/200/Custom V DC** w/Offset and 24V Exc.
ID07 . . . DC-Milliamper, **2/20/200mA DC** w/Offset and 24V Exc
ID09 . . . DC-Amps, **1A DC**
IGYZ* . . . Universal Direct Pressure

*View the IG- Ordering Code on page 14 to determine the value for Y & Z (IGAZ to IGKZ)
IP01 . . . Process Loop, **4-20mA(0-100.00)**

IP02 . . . Process Loop, **4-20mA(0-100.00)** w/24VDC Exc
IP03 . . . Process Input, **1-5V DC(0-100.00)** w/Offset, 24V Exc
IP07 . . . Universal Process 2V/5V/**10V/20V/200V/2mA/20mA/Custom**
IPT1 . . . Prototype Board for Custom Design
IR02 . . . 3-Wire Potentiometer 1KΩ min (0-F.S.)
IR03 . . . Linear Potentiometer, 3-wire, 1KΩ min
IR05 . . . Resistance 2KΩ
IS01 . . . Strain Gage 5/10VDC Exc., 20/**2mV/V, 4/6-wire**
IS02 . . . Pressure 5/10VDC Exc., 20/**2mV/V, 4/6-wire**
IS04 . . . Pressure Ext Exc., 20/**2mV/V, 4/6-wire**
IS05 . . . Pressure/Load Cell 20/**2mV/V, 5/10V Exc 4-wire**
IS06 . . . Pressure/Load Cell Ext Exc., 20/**2mV/V, 4-wire**
IS07 . . . Pressure 20/**2mV/V** with High Impedance and External Excitation

► ANALOG OUTPUT

OIC . . . Isolated 16 Bit Current Output, 4-20mA
OIV . . . Isolated 16 Bit Voltage Output, 0-10VDC

► RELAY OUTPUT

R11 . . . Single 10A Form C Relay
R12 . . . Dual 10A Form C Relays
R13 . . . Dual 10A Form C & One 5A Form A Relays
R14 . . . Dual 10A Form C & Dual 5A Form A Relays
R15 . . . Single 10A Form C & Dual 5A Form A Relays
R16 . . . Single 10A Form C & Single 5A Form A Relays

Special Options and Accessories

Part Number Description

► SPECIAL OPTIONS (Specify Inputs or Outputs & Req. Reading)

CR-CHANGE Calibrated Range Change to another Standard Range
CS-L/BAR Custom Scaling within any Stnd. or Custom Selectable Range
CSR-L/BAR Custom Selectable Range Installation or Modification
CSS-L/BAR Custom Special Scaling beyond the Standard Range
COA-L/SINGLE Custom Output - Special Scaling of Analog Output
COR-L/RELAY Custom Output - Relays Installed in Non-Standard Locations
CCP-L/SETUP NRC to Set-up Custom Configuration - Functions, Codes
CCP-L/INSTL Factory Installation - Custom Configuration

► ACCESSORIES (Specify Serial # for Custom Artwork Installation)

75-DMC14436B Side Slide Brackets-Wide opening (2 pc)
75-DMC144X36 Side Slide Brackets-stand. (2 pc) - extra set
93-PLUG2P-DP Extra Screw Terminal Conn., 2 Pin Power Plug
93-PLUG2P-DR Extra Screw Terminal Conn., 2 Pin Plug
93-PLUG3P-DR Extra Screw Terminal Conn., 3 Pin Plug
93-PLUG4P-DR Extra Screw Terminal Conn., 4 Pin Plug
93-PLUG5P-DR Extra Screw Terminal Conn., 5 Pin Plug
OP-MTL144x36 Metal Surround Case, includes screw mounting clips
OP-MTLCLIP Screw Mounting Clips (2 pc) - to screw tighten slide brackets
OP-N4/144X36 144x36mm clear lockable front cover-NEMA 4X, splash proof
OP-PA/144X36 Panel Adapter for 144x36mm from 6 inch cutout

For Custom Face Plates and Scales see page 19.

Many other options and accessories are available. See full price list for more details. Prices subject to change without notice.

WARRANTY

Texmate warrants that its products are free from defects in material and workmanship under normal use and service for a period of one year from date of shipment. Texmate's obligations under this warranty are limited to replacement or repair, at its option, at its factory, of any of the products which shall, within the applicable period after shipment, be returned to Texmate's facility, transportation charges pre-paid, and which are, after examination, disclosed to the satisfaction of Texmate to be thus defective. The warranty shall not apply to any equipment which shall have been repaired or altered, except by Texmate, or which shall have been subjected to misuse, negligence, or accident. In no case shall Texmate's liability exceed the original purchase price. The aforementioned provisions do not extend the original warranty period of any product which has been either repaired or replaced by Texmate.

USER'S RESPONSIBILITY

We are pleased to offer suggestions on the use of our various products either by way of printed matter or through direct contact with our sales/application engineering staff. However, since we have no control over the use of our products once they are shipped, **NO WARRANTY WHETHER OF MERCHANTABILITY, FITNESS FOR PURPOSE, OR OTHERWISE** is made beyond the repair, replacement, or refund of purchase price at the sole discretion of Texmate. Users shall determine the suitability of the product for the intended application before using, and the users assume all risk and liability whatsoever in connection therewith, regardless of any of our suggestions or statements as to application or construction. In no event shall Texmate's liability, in law or otherwise, be in excess of the purchase price of the product.

Texmate cannot assume responsibility for any circuitry described. No circuit patent or software licenses are implied. Texmate reserves the right to change circuitry, operating software, specifications, and prices without notice at any time.



1934 Kellogg Ave. Carlsbad, CA 92008

Tel: 1-760-598-9899 • USA 1-800-839-6283 • That's 1-800-TEXMATE

Fax: 1-760-598-9828 • Email: sales@texmate.com • Web: www.texmate.com

For product details visit www.texmate.com

Local Distributor Address