

# SM-35-DCV

Easily-Scaled 5V DC Powered 3.5 Digit Panel Meter



Selectable Multi-range:  
50mVDC, 100mVDC Current Shunt,  
2V, 20V and 200V with optional 1000VDC  
range, optional 4-20mA, optional 5V isolator  
and optional Differential Measurement

**Great for High Voltage EV Battery and Solar Battery Range**

## General Features

The SM-Series meters have LCD or LED displays and offer many unique features designed to simplify installation, calibration and scaling. SM-35-DCV and SM-35X-DCV meters are pin-compatible, which enables LED and LCD meters to be interchanged within the same panel without necessitating wiring or panel cutout changes.

All SM-Series meters are powered with bipolar single-ended inputs with optional differential measurement. The meters feature Display Hold, Display Test and Auto-Polarity indication.

The SM-series of meters are designed to be user scalable to almost any engineering unit of readout. On-site scaling and recalibration is facilitated by multi-turn potentiometers that provide continuous adjustment within each of the six header-programmable full scale ranges.

The five ranges provided with the SM-35-DCV (LED display) and SM-35X-DCV (LCD display) are 50mV, 100mV current shunt, 2V, 20V and 200V DC full scale. 5V power isolator, 1000V DC range, 4-20mA and Differential Measurement are factory installed options only.

Both SM-35-DCV and SM-35X-DCV have Zero-offset and Span adjustment potentiometers as a standard feature.

## 4 to 20mA Process Loop Connections

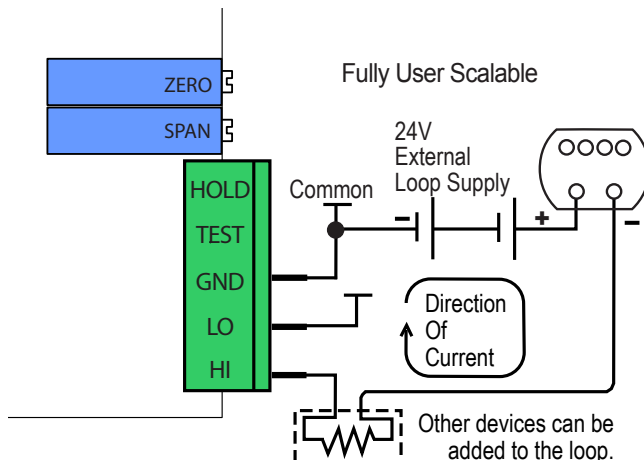

## Specifications

**Input Configuration:** .....Single-ended, with optional differential measurement and provision to offset the zero of the reading displayed

**Input Impedance:** .....1MΩ minimum

**Full Scale Ranges:** .....±2VDC (Meters shipped with 2V range selected) ±20VDC, ±200VDC, 50mVDC and 100mVDC ranges are header programmable.

**A/D Converter:** .....12 Bit Dual Slope

**Accuracy:** .....±(0.05% of reading + 2 digits)

**Temperature Coefficient:** 100ppm/°C typical

**Warmup Time:** .....One minute to specified accuracy

**Conversion Rate:**.....3 readings per second

**Display:**.....0.56" High efficiency LED's "Display Hold" feature

**Decimal Selection:** .....User programmable to 3 positions

**Over-range Indication:** ...When input exceeds full scale on any range being used, most significant "1" digit and polarity symbol are displayed with all other digits blank

**Power Supply:** .....+4.5 to +5.5V DC at 150mA;  
Optional 1.5kV 5V Isolation

**Operating Temperature:**... 0°C to +60°C

**Storage Temperature:** .....-20° to +70°C

**Relative Humidity:** .....95% (non-condensing)

**Case Dimensions:** .....Bezel 2.76" x 1.17" (69.75 x 29.7mm)  
Depth behind Bezel 3.32"(84mm) plus 0.68" (17.27mm) for connector.

**Weight:** .....88 gms (3.1 oz)  
143 gms (5 oz) when packed

## SM-Series with LCD Display

**SM-35X-DCV** .....3.5 digit LCD with back light, 5VDC Powered  
input ranges: 50mV/100mV/2/20/200/1000VDC

## Open the Meter to Select Input

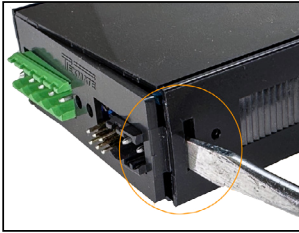

To open meter, insert a flat head screwdriver or similar instrument in both slots on the side of the cover and pry open.

## Component Layout

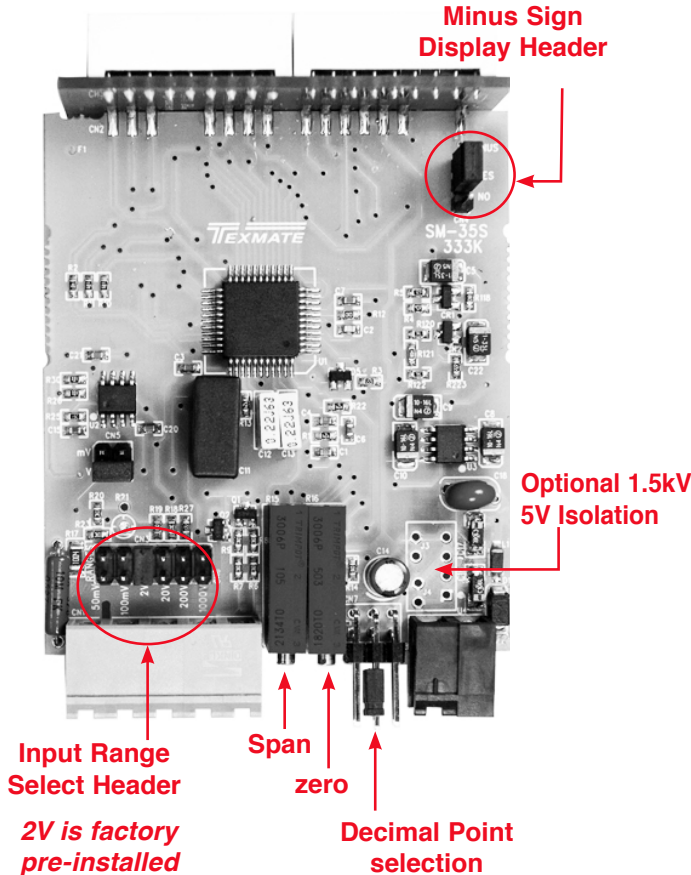

## Connector Pinouts

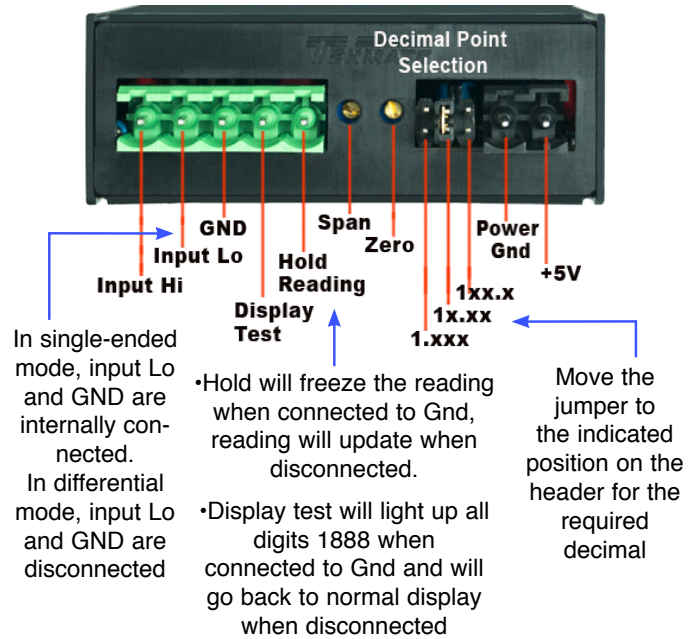

## Signal Conditioning Components

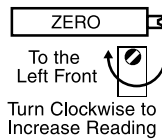

### ZERO Potentiometer (Pot)

The ZERO pot is to the right of the SPAN pots (as viewed from the back of the meter). Typically it enables the displayed reading to be offset  $\pm 1000$  counts. Not available on differential option

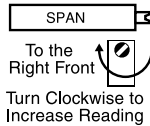

### SPAN Potentiometer (Pot)

The SPAN pot is on the right side of the signal input. Typical adjustment is 100% of the input signal range.

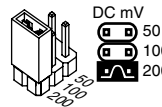

### RANGE SELECT Header

Range values are marked on the PCB. six positions are provided. After selecting a new range with the single jumper clip, recalibration is required.

## Minus Sign Header

- NO YES  
Activates Minus sign on display
- NO YES  
Disable Minus sign on display\*

### Minus Sign Header

This header allows the Minus Sign to work normally.

\*Note: Removing the header disables Minus Sign

## Connectors

This meter uses plug-in type screw terminal connectors for all input and output connections. The power supply connections have a unique plug and socket outline to prevent cross connection. The main board uses standard right-angled connectors.

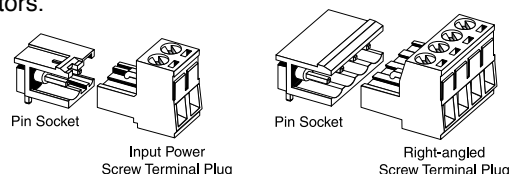

**WARNING:** AC and DC input signals and power supply voltages can be hazardous. Do Not connect live wires to screw terminal plugs, and do not insert, remove or handle screw terminal plugs with live wires connected.



## Calibration Procedure

- 1) Select the DC Volt input range 20V, for example, by re-positioning the jumper clip on the range select headers indicated by and marked on the PCB Range select Header, shown on Component Layout section.
- 2) Input 0VDC, meter will automatically will display 000 or adjust Zero pot until meter display 000.
- 3) Apply at least 95% of full voltage range, eg 19V for a 20 DCVolt range.
- 4) Adjust Span pot until meter displays 19.00 (20V Range). For other ranges, the voltage applied should be similarly proportional to the particular full-scale voltage.

**CAUTION - ELECTRICAL SHOCK HAZARD** All internal parts of the meter may be at the same electrical potential as the input signal and power supply. Do not reposition the signal conditioning components when input voltages are applied. When measuring dangerously high input voltages, extreme care must be taken to insulate the connector pins as well as all metal parts of the meter. A suitable high voltage warning notice should be affixed to those meters where there is any possibility that the meter could be removed from its case, or the internal components accessed, concurrent with the existence of a high voltage input signal.

