

MULTI-DIGITAL 16 INPUT 22 OUTPUT MODULE

MULTI-DIGITAL 16 INPUT 22 OUTPUT MODULE

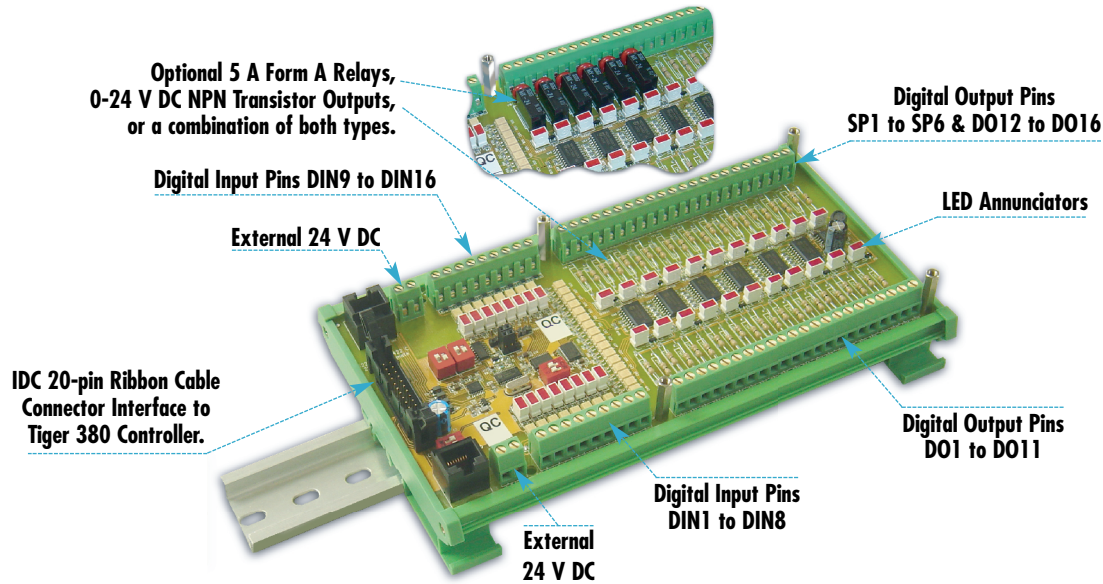

A multi-digital I/O module for I/O intensive applications with Tiger 380 Series controllers.

Input / Output Module Order Code Suffix

OR83: 16 Inputs, 22 outputs

**Fits Tiger
380 Series**



Introduction

The DIN-rail mounted 1622 multi-digital I/O module combines 16 opto-isolated digital inputs with either 22 opto-isolated open collector outputs, 22 Form A 5 amp relays, or a combination of both types. The I/O module connects to the 380 Series controller through a multi I/O driver board via an IDC ribbon cable with an IDC 20-pin snap-in connector for quick and easy connection. The digital input and output terminals are easily identifiable on the module and connect using screw terminals.

LED annunciators located beside each digital I/O device indicates operation and diagnostic identification of the control position, making this module ideal for machine control and automation applications.

Digital inputs DIN1 to DIN16 and switched outputs DO1 to DO16 are controlled by a pre-programmed macro. Setpoints SP1 to SP6 can be controlled by either the 380 Series controller's operating system or a pre-programmed macro.

Specifications

Digital Inputs – DIN1 to DIN16

- 0 to +24 V DC, open collectors sink or source, and sink or source switches.
 - Sink or source input selected in two blocks DIN 1 to DIN8 and DIN9 to DIN16.
- See External Connections to the Multi-I/O Module OR83 diagram on Page 2.*
- Inputs isolated to controller ground by 3750 V rms for 1 minute.

Digital Outputs – SP1 to SP6 and DO1 to DO16

- Open collector N-channel short circuit protected transistor outputs, 500 mA max, 24 V DC.
- Outputs isolated to controller ground by 3750 V rms for 1 minute.
- 5 A Form A Relays: 5 A, 240 V AC; 5 A, 24 V DC. Isolation: 3000 V UL and CSA tested.

Power Supply

- 24 V DC $\pm 15\%$.
- Quiescent Current Draw: 20 mA + 8 mA per active digital input + 10 mA per active relay output.
- Load Current: A total of 5 A can be drawn through all open collector outputs.

External Connections to the Multi-I/O Module OR83

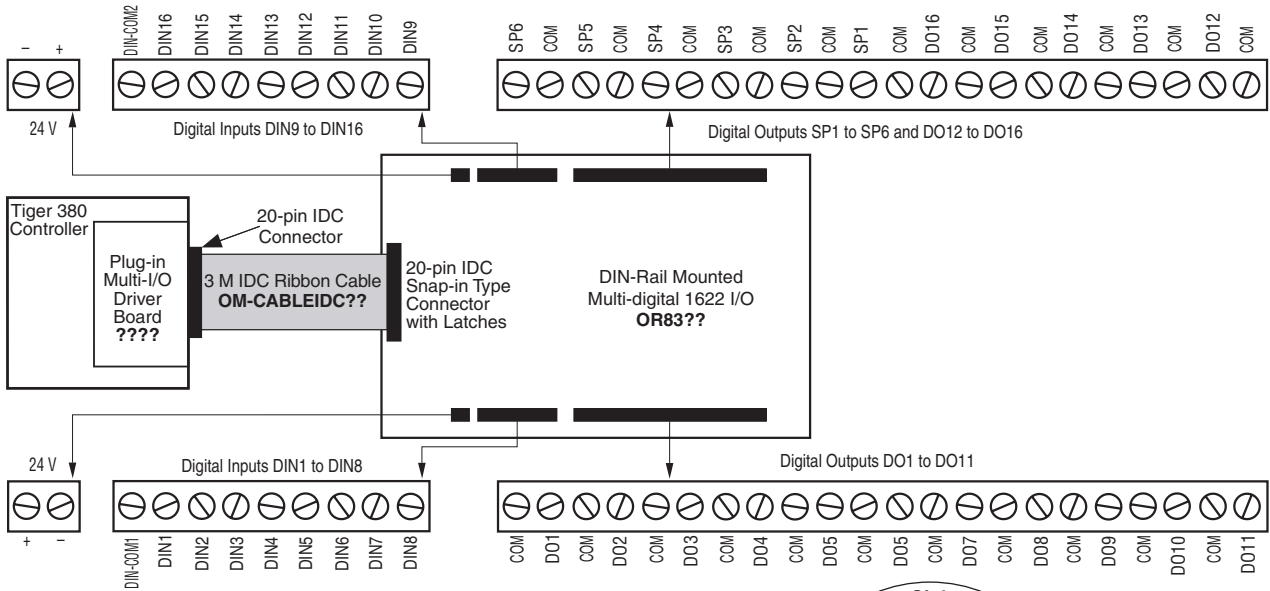

16 Digital Inputs

See table opposite for digital input specifications and a circuit diagram.

Connecting DIN-COM1 to 24 V results in DIN1 to DIN8 becoming **sink** inputs.

Connecting DIN-COM2 to 24 V results in DIN9 to DIN16 becoming **sink** inputs.

See Sink diagram opposite.

Connecting DIN-COM1 to 0 V results in DIN1 to DIN8 becoming **source** inputs.

Connecting DIN-COM2 to 0 V results in DIN9 to DIN16 becoming **source** inputs.

See Source diagram opposite.

16 Digital Inputs	
Item	Specifications
Input voltage	24 V DC, +10%/-15%
Input impedance	3.3 kΩ
Input current (typical)	6 mA
ON voltage	14.4 V DC min.
OFF voltage	5.0 V DC max.
ON delay	10 ms (See Note)
OFF delay	10 ms (See Note)

Digital Input Circuit

Note: The polarity of the input power supply can be either positive or negative.

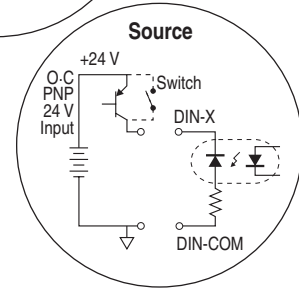
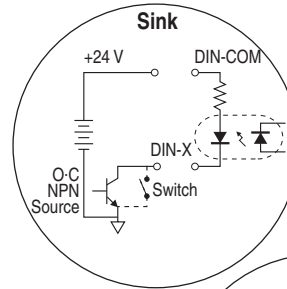

22 Open Collector Outputs

See table opposite for open collector output specifications and a circuit diagram.

22 Relay Outputs

See table opposite far-right for relay output specifications and a circuit diagram.

22 Open Collector Outputs		OR	22 Relay Outputs	
Item	Specifications	Item	Specifications	
Switch type:	Ruggedized MOSFET.	Relay type:	5 A Form A.	
Max. switching capacity:	700 mA, 24 V DC, +10%/-15%	Max. switching capacity:	5 A, 240 V AC.	
Leakage current:	0.1 mA max.	Isolation:	0.1 mA max.	
ON state voltage:	0.2 V max at 0.5 A.	Listed:	UL and CSA.	
ON delay:	10 ms max.			
OFF delay:	10 ms max.			
Protection:	Short-circuit protection. Over temperature protection. Over fatigue clamping for turn-off of inductive loads.			

Digital Open Collector Output Circuit

Relay Circuit

Channel 1 Block Diagram

Header 1 (HDR1)

Header 1 is used by Texmate to configure the multi I/O module prior to shipping. The jumpers must remain in the position shown for the module to operate correctly.



Programming Macro Controlled Inputs and Outputs

The 380 Series controller's standard inputs (CH1 to CH4) and setpoint outputs (SP1 to SP6) can be fully programmed from the front panel or through the serial port using the Texmate configuration utility program.

See your Tiger 380 Series manual for configuration procedures for standard inputs (CH1 to CH4) and setpoint outputs (SP1 to SP6).

The 16 digital inputs (DIN1 to DIN16) and 22 digital outputs, including SP1 to SP6, on the 1622 multi-I/O module can only be operated through a macro.

Note:

If SP1 to SP6 are operated through a macro, this overrides any other programmed settings.

Macro control of the I/O module is through controller registers 249 and 251:

- Digital Outputs: Register Number 249 – SP1 to SP6 and DO1 to DO16. *See Table 1.*
- Digital Inputs: Register Number 251 – DIN1 to DIN16. *See Table 2.*

Register Number 239

A 32-bit register with output bit flags to indicate the status of the 6 setpoints (Bit 0 to Bit 5 only). In the normal mode of operation the status of each setpoint is controlled by the controller, based on a comparison between the input value and the setpoint value. The status of the setpoint is controlled directly by setting or clearing the appropriate status bit. This can be done from the serial port or from a macro. The bit functions are described in Table 1.

Table 1 Digital or Relay Outputs SP1 to SP6				
Digital Output	Register Name	Description	Symbol Type	Register Number
SP1	SP_1	Bit flag which shows/controls the status of digital output 1 on the multi I/O module (1=output active, 0=output inactive).	B_0	239
SP2	SP_2	Bit flag which shows/controls the status of digital output 2 on the multi I/O module (1=output active, 0=output inactive).	B_1	239
SP3	SP_3	Bit flag which shows/controls the status of digital output 9 on the multi I/O module (1=output active, 0=output inactive).	B_2	239
SP4	SP_4	Bit flag which shows/controls the status of digital output 4 on the multi I/O module (1=output active, 0=output inactive).	B_3	239
SP5	SP_5	Bit flag which shows/controls the status of digital output 5 on the multi I/O module (1=output active, 0=output inactive).	B_4	239
SP6	SP_6	Bit flag which shows/controls the status of digital output 6 on the multi I/O module (1=output active).	B_5	239

For detailed information on Tiger 380 series controller registers, see Texmate document: 380 Register Supplement (NZ801).

As the 1622 multi-I/O module can only be fully utilized using a macro, it is assumed that the user is familiar with macro programming.

For detailed information on programming macros for Tiger 380 series controllers, see Texmate document: TDS Macro Tutorial (NZ212).

Register Number 249

A 32-bit register with output bit flags to control up to 32 digital outputs controlled by a macro. The bit functions are described in Table 2.

Table 2 Digital Outputs DO1 to DO16				
Digital Output	Register Name	Description	Symbol Type	Register Number
DO1	DO_1	Digital output 1. Bit flag which shows/controls the status of digital output 1 on the multi I/O module (1=output active, 0=output inactive).	B_0	249
DO2	DO_2	Digital output 2. Bit flag which shows/controls the status of digital output 2 on the multi I/O module (1=output active, 0=output inactive).	B_1	249
DO3	DO_3	Digital output 3. Bit flag which shows/controls the status of digital output 9 on the multi I/O module (1=output active, 0=output inactive).	B_2	249
DO4	DO_4	Digital output 4. Bit flag which shows/controls the status of digital output 4 on the multi I/O module (1=output active, 0=output inactive).	B_3	249
DO5	DO_5	Digital output 5. Bit flag which shows/controls the status of digital output 5 on the multi I/O module (1=output active, 0=output inactive).	B_4	249
DO6	DO_6	Digital output 6. Bit flag which shows/controls the status of digital output 6 on the multi I/O module (1=output active).	B_5	249
DO7	DO_7	Digital output 7. Bit flag which shows/controls the status of digital output 7 on the multi I/O module (1=output active, 0=output inactive).	B_6	249
DO8	DO_8	Digital output 8. Bit flag which shows/controls the status of digital output 8 on the multi I/O module (1=output active, 0=output inactive).	B_7	249
DO9	DO_9	Digital output 9. Bit flag which shows/controls the status of digital output 9 on the multi I/O module (1=output active, 0=output inactive).	B_8	249
DO10	DO_10	Digital output 10. Bit flag which shows/controls the status of digital output 10 on the multi I/O module (1=output active, 0=output inactive).	B_9	249
DO11	DO_11	Digital output 9. Bit flag which shows/controls the status of digital output 9 on the multi I/O module (1=output active, 0=output inactive).	B_10	249
DO12	DO_12	Digital output 8. Bit flag which shows/controls the status of digital output 8 on the multi I/O module (1=output active, 0=output inactive).	B_11	249
DO13	DO_13	Digital output 9. Bit flag which shows/controls the status of digital output 9 on the multi I/O module (1=output active, 0=output inactive).	B_12	249
DO14	DO_14	Digital output 10. Bit flag which shows/controls the status of digital output 10 on the multi I/O module (1=output active, 0=output inactive).	B_13	249
DO15	DO_15	Digital output 9. Bit flag which shows/controls the status of digital output 9 on the multi I/O module (1=output active, 0=output inactive).	B_14	249
DO16	DO_16	Digital output 9. Bit flag which shows/controls the status of digital output 9 on the multi I/O module (1=output active, 0=output inactive).	B_15	249

Register Number 251

A 32-bit register with read only output bit flags to control up to 32 digital outputs controlled by a macro. The multi I/O module uses only 16 of these. The bit functions are described in Table 3.

Table 3 Digital Inputs DIN1 to DIN16				
Digital Input	Register Name	Description	Symbol Type	Register Number
DIN1	DI_1	Digital input 1. Read only bit flag that shows the status of digital input 1 on the multi I/O module (1=input active).	B_0_R	251
DIN2	DI_2	Digital input 2. Read only bit flag that shows the status of digital input 2 on the multi I/O module (1=input active).	B_1_R	251
DIN3	DI_3	Digital input 3. Read only bit flag that shows the status of digital input 3 on the multi I/O module (1=input active).	B_2_R	251
DIN4	DI_4	Digital input 4. Read only bit flag that shows the status of digital input 4 on the multi I/O module (1=input active).	B_3_R	251
DIN5	DI_5	Digital input 5. Read only bit flag that shows the status of digital input 5 on the multi I/O module (1=input active).	B_4_R	251
DIN6	DI_6	Digital input 6. Read only bit flag that shows the status of digital input 6 on the multi I/O module (1=input active).	B_5_R	251
DIN7	DI_7	Digital input 2. Read only bit flag that shows the status of digital input 2 on the multi I/O module (1=input active).	B_6_R	251
DIN8	DI_8	Digital input 3. Read only bit flag that shows the status of digital input 3 on the multi I/O module (1=input active).	B_7_R	251
DIN9	DI_9	Digital input 4. Read only bit flag that shows the status of digital input 4 on the multi I/O module (1=input active).	B_8_R	251
DIN10	DI_10	Digital input 5. Read only bit flag that shows the status of digital input 5 on the multi I/O module (1=input active).	B_9_R	251
DIN11	DI_11	Digital input 6. Read only bit flag that shows the status of digital input 6 on the multi I/O module (1=input active).	B_10_R	251
DIN12	DI_12	Digital input 2. Read only bit flag that shows the status of digital input 2 on the multi I/O module (1=input active).	B_11_R	251
DIN13	DI_13	Digital input 3. Read only bit flag that shows the status of digital input 3 on the multi I/O module (1=input active).	B_12_R	251
DIN14	DI_14	Digital input 4. Read only bit flag that shows the status of digital input 4 on the multi I/O module (1=input active).	B_13_R	251
DIN15	DI_15	Digital input 5. Read only bit flag that shows the status of digital input 5 on the multi I/O module (1=input active).	B_14_R	251
DIN16	DI_16	Digital input 6. Read only bit flag that shows the status of digital input 6 on the multi I/O module (1=input active).	B_15_R	251

Example

Digital outputs DO1 and DO2 are controlled by digital output registers DO_1 and DO_2 and are renamed PUMP and VALVE in the example macro screen below. Digital inputs DIN1 and DIN2 are controlled by digital input registers DI_1 and DI_2 and are renamed UPPER_LEVEL and LOWER_LEVEL in the example macro screen.

The Main Macro reads the level of inputs DIN1 and DIN2 and controls the pump and valve status (ON or OFF) via setpoints SP5 and SP6.

```
1 //*****
2 //                               Example macro for I/O module
3
4 BIT | PUMP=|DO_1                // output |DO_1 is renamed as |PUMP
5 BIT | VALVE=|DO_2              // output |DO_2 is renamed as |VALVE
6
7 BIT | UPPER_LEVEL=|DI_1        // input |DI_1 is renamed as |UPPER_LEVEL
8 BIT | LOWER_LEVEL=|DI_2       // input |DI_2 is renamed as |LOWER_LEVEL
9
10 Main_Macro:
11 IF |UPPER_LEVEL = ON THEN
12   |PUMP=ON
13   |VALVE=OFF
14
15 ELSIF |LOWER_LEVEL = OFF THEN
16   |PUMP=OFF
17   |VALVE=ON
18 ENDIF
19 END
```

Texmate Tiger Macro Development System (TDS)

Tiger 380 Macro Overview

The Tiger 380 Series of programmable meter controllers has been designed to incorporate the analog and digital functionality of an intelligent controller with the logic of a PLC.

Traditionally, the PLC approach is to build a working application entirely in some form of programming language. The approach used in the Tiger 380 Series of controllers is to build an application by selecting the pre-programmed functions of the controller and then adding small amounts of programmability and logic where needed.

The operating system of the Tiger 380 controller controls all the pre-programmed functions, handling the input, averaging, scaling, linearization, totalization and much more, as well as driving the display, timers, relays, analog and serial outputs. Once configured, these functions are executed by the operating system and form the basis of a control system.

To form an advanced automation and control system you only need to write a small program that adds the extra logic required. We call this program a macro. A macro can be written specifically for your application and is used to initiate a sequence, reconfigure, or disable some of the controller functions. With Texmate's multi-I/O plug-in module installed (OR83), a macro further expands the Tiger 380 operating system with additional digital status inputs and digital switched outputs.

Macro control is ideal for many OEM applications that require analog, digital, and timer functions with sophisticated mathematical and enhanced logic operations. The macro concept has major cost advantages for large or small sophisticated applications that require some degree of programmable logic control with display and front panel control.

Custom Macro Programming

Texmate's Tiger macro development system (TDS) enables a macro to be written and compiled in BASIC, utilizing any combination of the hundreds of functions and thousands of registers embedded in the Tiger 380 Operating System. When your BASIC program is compiled into Tiger 380 Macro-language it is error checked and optimized.

Macros are useful when implementing a specialized control system that cannot be achieved by the standard configuration capability of the Tiger 380 Operating System. Using the TDS software, functions can be altered or added in a standard controller to perform the required job. This may typically include logic sequencing functions and mathematical functions.

Developing a Macro is much easier and quicker than programming a PLC, because the basic code required to customize the Tiger meter is considerably less than the ladder logic programming required for PLCs. This is due to the hundreds of functions built into the Tiger controller that can be manipulated or invoked by a macro to fulfill the requirements of almost any application.

WARRANTY

Texmate warrants that its products are free from defects in material and workmanship under normal use and service for a period of one year from date of shipment. Texmate's obligations under this warranty are limited to replacement or repair, at its option, at its factory, of any of the products which shall, within the applicable period after shipment, be returned to Texmate's facility, transportation charges pre-paid, and which are, after examination, disclosed to the satisfaction of Texmate to be thus defective. The warranty shall not apply to any equipment which shall have been repaired or altered, except by Texmate, or which shall have been subjected to misuse, negligence, or accident. In no case shall Texmate's liability exceed the original purchase price. The aforementioned provisions do not extend the original warranty period of any product which has been either repaired or replaced by Texmate.

USER'S RESPONSIBILITY

We are pleased to offer suggestions on the use of our various products either by way of printed matter or through direct contact with our sales/application engineering staff. However, since we have no control over the use of our products once they are shipped, NO WARRANTY WHETHER OF MERCHANTABILITY, FITNESS FOR PURPOSE, OR OTHERWISE is made beyond the repair, replacement, or refund of purchase price at the sole discretion of Texmate. Users shall determine the suitability of the product for the intended application before using, and the users assume all risk and liability whatsoever in connection therewith, regardless of any of our suggestions or statements as to application or construction. In no event shall Texmate's liability, in law or otherwise, be in excess of the purchase price of the product.

Texmate cannot assume responsibility for any circuitry described. No circuit patent or software licenses are implied. Texmate reserves the right to change circuitry, operating software, specifications, and prices without notice at any time.



995 Park Center Drive • Vista, CA 92081-8397

Tel: 1-760-598-9899 • USA 1-800-839-6283 • That's 1-800-TEXMATE

Fax: 1-760-598-9828 • Email: sales@texmate.com • Web: www.texmate.com

Texmate has facilities in Japan, New Zealand, Taiwan, and Thailand. We also have authorized distributors throughout the USA and in 28 other countries.

For product details visit www.texmate.com

Local Distributor Address

Copyright © 2003 Texmate Inc. All Rights Reserved.