

LYNX FAMILY

## FX-B101Q

Lynx Bargraph Meter  
101 LED Segments  
in a 9/64 DIN Case

A low cost, red or green 101 segment bargraph in a 36x144mm case with QUICKSET programming, and an optional, independently scaled, isolated 4 to 20 mA retransmission output.



### General Features

- External transmitters or signal conditioners can be eliminated by directly connecting the sensor to more than 33 **I-Series** Plug-in Input Signal Conditioning Modules that include:
  - AC Current
  - AC Voltage
  - DC Current
  - DC Voltage
  - Load Cell
  - Pressure
  - Process
  - Prototype
  - Resistance
  - Strain-gage
  - Temperature
  - 4 to 20 mA
- Pre-calibrated **I-Series** Input Signal Conditioning modules, that have span or zero potentiometers, can be interchanged between any **I-Series** compatible meter, without recalibration, because all of the analog scaling and reference circuitry is self-contained within the module. 5 or 10 V DC excitation is provided for resistance bridge type sensors.
- 24 V DC excitation is available to power external transmitters and 5 or 10 V DC excitation is available for strain-gages, load cells and resistance bridge type sensors.
- A red or optional green 101 segment bargraph.
- Auto-sensing AC/DC power supply. For voltages between **85-265 V AC / 95-370 V DC (PS1)** or 15-48 V AC / 10-72 V DC (PS2).
- Optional 16 Bit isolated analog output that can be used to drive an external process device such as a chart recorder, remote display, or for retransmission to a central control room. User or factory scalable to 4 to 20 mA, 0 to 20 mA or 0 to 10 V across any desired span from  $\pm$  one bar to the full scale range
- Center zero setting, header selectable.
- Provision for external brightness setting switch (by connecting the DIM to the GND pin on the back of the meter).
- Smart averaging (to speed up display response).
- Optional NEMA-4 front cover.

### Input Module Compatibility

**LYNX FAMILY:** More than 30 different Plug-in **I-Series** Input Signal Conditioners are approved for Texmate's Lynx Family of meters. As shown on pages 10 to 12.



LYNX

See [www.texmate.com](http://www.texmate.com) for an up to date listing.

### Specifications

**Input Specs:** .....Depends on range and function selected  
**A/D Converter:** .....14 bit single slope  
**Accuracy:** ..... $\pm(0.05\%$  of reading + 1segment)  
**Temp. Coeff.:** .....100 ppm/ $^{\circ}$ C (Typical)  
**Warm up time:** .....2 minutes  
**Conversion Rate:** .....10 conversions per second (Typical)  
**Bargraph Display:** ....**101 segment 4" vertical (std)**, horizontal (optn), **red (std)**, green (optn)  
**Polarity:** .....Selectable center zero  
**Positive Overrange:**..Bargraph display flashes  
**Negative Overrange:** First segment of bargraph display flashes  
**Analog Output:** .....Isolated 16 bit user scalable mA or V  
**OIC (mA out)** .....4-20 mA @ 0 to 500 $\Omega$  max loop resistance  
**OIV (volts out)** .....0-10 V DC @ 500  $\Omega$  or higher resistance  
**Power Supply:** .....AC/DC Auto sensing wide range supply  
**PS1 (std)**.....**85-265 VAC / 95-370 VDC @ 2.5W max 4.2W**  
**Operating Temp.:** ....0 to 60 $^{\circ}$ C  
**Storage Temp:** .....–20 $^{\circ}$ C to 70 $^{\circ}$ C  
**Relative Humidity:** ....95% (non condensing)  
**Case Dimensions:** ....3/32 DIN, Bezel: 36x144 mm (1.42"x5.69")  
 Depth behind bezel: (4.64") 117.5 mm  
 Plus 10 mm (0.39") for Right-angled connector, or plus 18.3 mm (0.72") for Straight-thru connector, or plus 26.5 mm (1.05") for Push-On connector.  
**Weight:** .....9.5 oz., 12 oz when packed

### Index

Analog Output Scaling and Calibration .....	7	Functional Diagram .....	8	I-Series Input Signal Conditioning Modules .....	10-12	Pin Descriptions .....	8
Case Dimensions .....	19	General Features .....	1	One Point Quickset Rescaling and Calibration Procedure .....	5	Specifications .....	1
Center Zero Mode Scaling For Bipolar Inputs .....	6	Glossary of Programming Symbols & Modes of Operation .....	2	Opening the Case to Access Mode Select Header .....	4	Standard Face Plates and Scales .....	16
Component Layout .....	9	Hinged Clear Lockable Poly NEMA 4X Splash Proof Cover .....	19	Ordering Information .....	20	Standard Display Mode Calibration Procedure .....	5
Connector Pinouts .....	8	Input Module Analog Calibration Procedures .....	15	Overview of Display Modes, Scaling Capabilities & Operating Modes .....	3	Standard Scales & Caption Sheets 16 Two Point Quickset Scaling and Calibration .....	3,5
Connectors .....	9	Input Module Compatibility .....	1	Panel Adapter .....	18		
Controls and Indicators .....	2	Input Module Component Glossary .....	14				
Custom Face Plates & Scales .....	17						

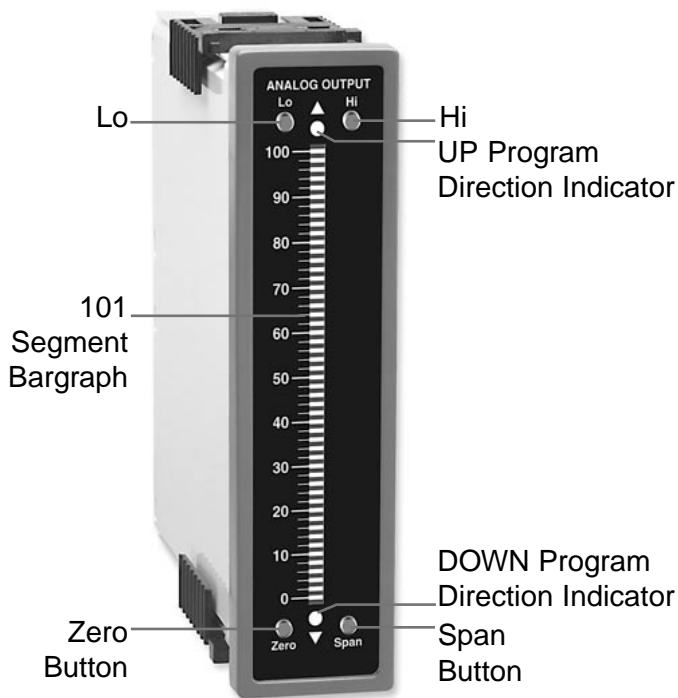

directly changed. The direction of change will be either up or down, as indicated by the UP and DOWN indicator LEDs. After the indicator LED lights up there is a 0.5 second delay before any change occurs. When a button is released and pressed down again the direction of change is reversed. As there are no menu or sub-menus to navigate, the programming and setup is quick and easy.

## Front Panel Buttons

### Zero Button

The Zero Button sets the low input signal scaling.

### Span Button

The Span Button sets the high input signal scaling.

### Lo Button

The Lo Button sets the analog output low setting.

### Hi Button

The Hi Button sets the analog output high setting.

## Quickset Programming

This bargraph features Texmate's unique QUICKSET PROGRAMMING. When a front panel button is pressed and held down, the associated function is

## Glossary of Programming Symbols and Modes of Operation

To explain software programming procedures, logic diagrams are used to visually assist in following programming steps. The following symbols are used to represent the functions and displays of the meter:

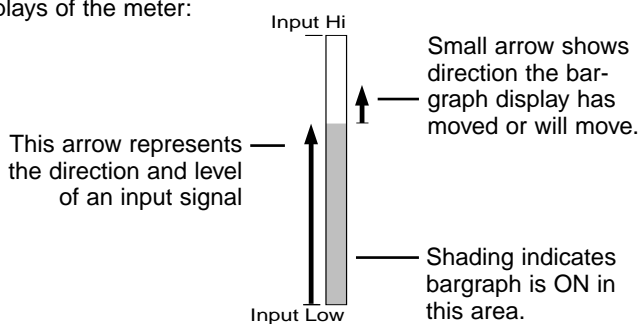

### Standard or Center Zero Display Mode Select Header

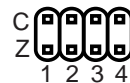

• Jumper clips enables standard display.



• Jumper clip to enable Center Zero display.



### Horizontal and Reverse Mounting

with Custom Face Plate Installed

#### Horizontal or Reverse Mounting

Meters can be mounted horizontally in the panel and for those applications that require an opposite growth of the bar, the meter can be vertically or horizontally mounted upside down

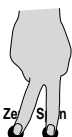
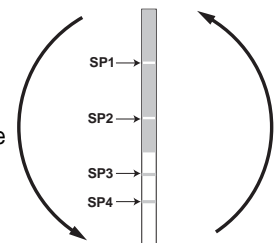

When two fingers are shown side by side, the two corresponding buttons must be pressed at the same time to initiate an indicated function.

## Over View of Display Modes, Scaling Capabilities and Operating Modes

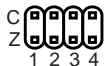

### Standard Display Mode

#### Standard Scaling

Standard display mode selected and scaled so bar increases as input signal increases from Low to Hi.

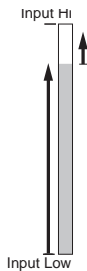

#### Inverse Scaling

Standard display mode selected and scaled so the bar increases as the input signal decreases from Hi to Low.

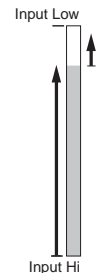

### Center Zero Display Mode

#### Bipolar Center Zero

Center point display mode selected and scaled, so the bar increases upward from zero, for increasing positive inputs and downward from zero for increasing negative inputs. When the input is zero, only the center segment will be on.

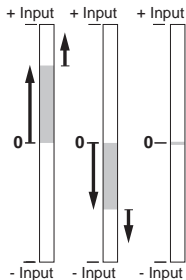

#### Halfway Zero Point

Center point display mode selected and scaled, so the bar increases upwards or downwards from the center point, for signals that are greater or less than half the calibrated full scale range respectively. When the input is equal to half the full scale range, only the center segment will be on.

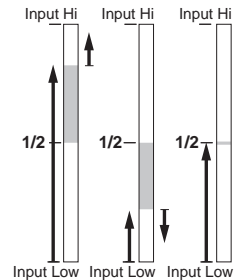

## Two Point Quickset Scaling and Calibration

Meters with **QUICKSET PROGRAMMING** feature a unique, easy-to-use, two point scaling and calibration system.

Scaling or calibration is accomplished simply, by applying a zero or low input signal and adjusting the bar to the desired reading, using the ZERO button. A higher input signal is then applied, and the bar is adjusted to the desired reading for that input value, using the SPAN button.

### IMPORTANT DETAILS THAT MAKE QUICKSET PROGRAMMING EASY TO USE AND UNDERSTAND

1. The zero and span buttons are functionally the same, except as follows: The ZERO button can initiate a scaling with input signals from zero to 95% of fullscale. The Span button can initiate a scaling with input signals from 5% of fullscale to 105% of fullscale.
2. When a Zero or Span button is pressed, the Up or Down indicator LED will immediately light up to show the direction, in which the Bar will move, after a 0.5 second delay. If the button is released and pressed again, the opposite Up or Down indicator will light up, and 0.5 seconds later the Bar will begin to move in that direction until the button is released. When the bar is being adjusted to zero or fullscale, the bar will automatically stop at the zero or fullscale position, and will not overshoot these positions, even if the button continues to be pressed.
3. While the bar is being adjusted, a new offset and scale factor is continuously being calculated. At the moment the button is released, and the scaling is accepted, the calculation data is memorized and implemented. The Scaling calculation is based on the new position of the Bar, the input signal being applied at that moment, and the previously memorized position of the Bar and the input signal that was being applied, when the other button was last released.
4. Positive and negative signals maybe integrated into a two point scaling. However when either a ZERO or SPAN button is pressed the input signal being applied, must be more than 5% higher or lower than the previously memorized value of the input signal, that was being applied when the other button was last released. If not, the bar will flash, the scaling will not be accepted, and the previous scaling will still be retained in memory.
5. Because of the requirement, that a new scaling input signal must be 5% higher or lower than the previously stored value, it can sometimes be difficult to implement a desired scaling, particularly when using a calibrator that only has fixed output values. In this case Reset the Scaling by pressing the ZERO and SPAN buttons simultaneously for two seconds. Both scaling memories will be erased and an internal default scale factor will be loaded. This provides a display of zero to fullscale on the bar for an input of approximately 0 to 100% of the range selected on the input signal conditioning module. After Resetting the Scaling a new calibration, using either button, can be implemented with new input signal values. It is good practice to always use the Zero button for lower input signals and the Span button for higher input signals, even when the bar display scale is inverted.
6. The larger the difference between two points used for calibration, the better the accuracy. However if the difference is too high, and the output from the input signal conditioning module is greater than +2.1VDC, or less than -1.05VDC, the bar will flash over range. The calibration will not then be accepted and, the previous scaling will still be retained in memory. In this case, either a lower input signal must be used, or a higher range on the input module should be selected to recalibrate the meter.

**Note:** Most input signal conditioners have provisions for analog calibration and scaling. If the meter's scale factor is set to read zero with a zero input (shorted input), and to read 10 Bars fullscale with a 2.000 V input, any pre-calibrated signal conditioner with an output that does not exceed - 1 V to + 2 V, will read correctly in the meter without any further calibration.

## Opening the Case to Access Mode Select Header

To remove front bezel lightly lever the plastic catches up and forward in the sequence shown by the numbers

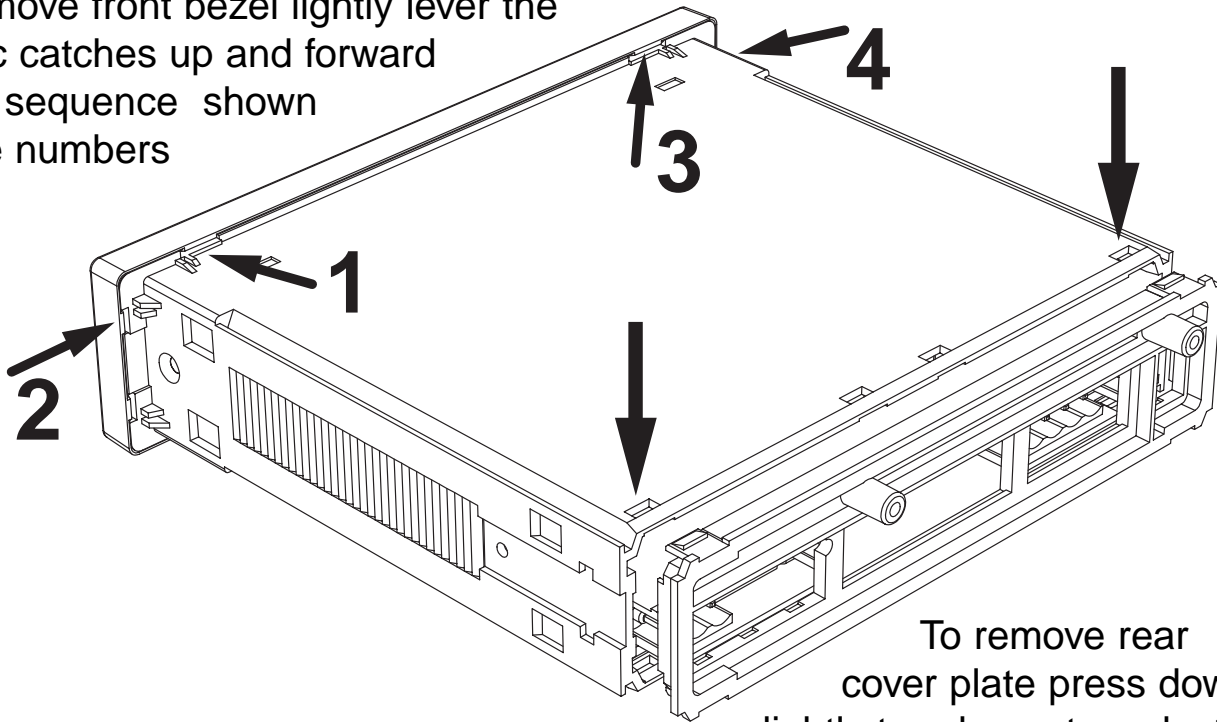

To remove rear cover plate press down lightly to release two plastic catches, on either side of the case and lever backwards.

Meter Exploded view

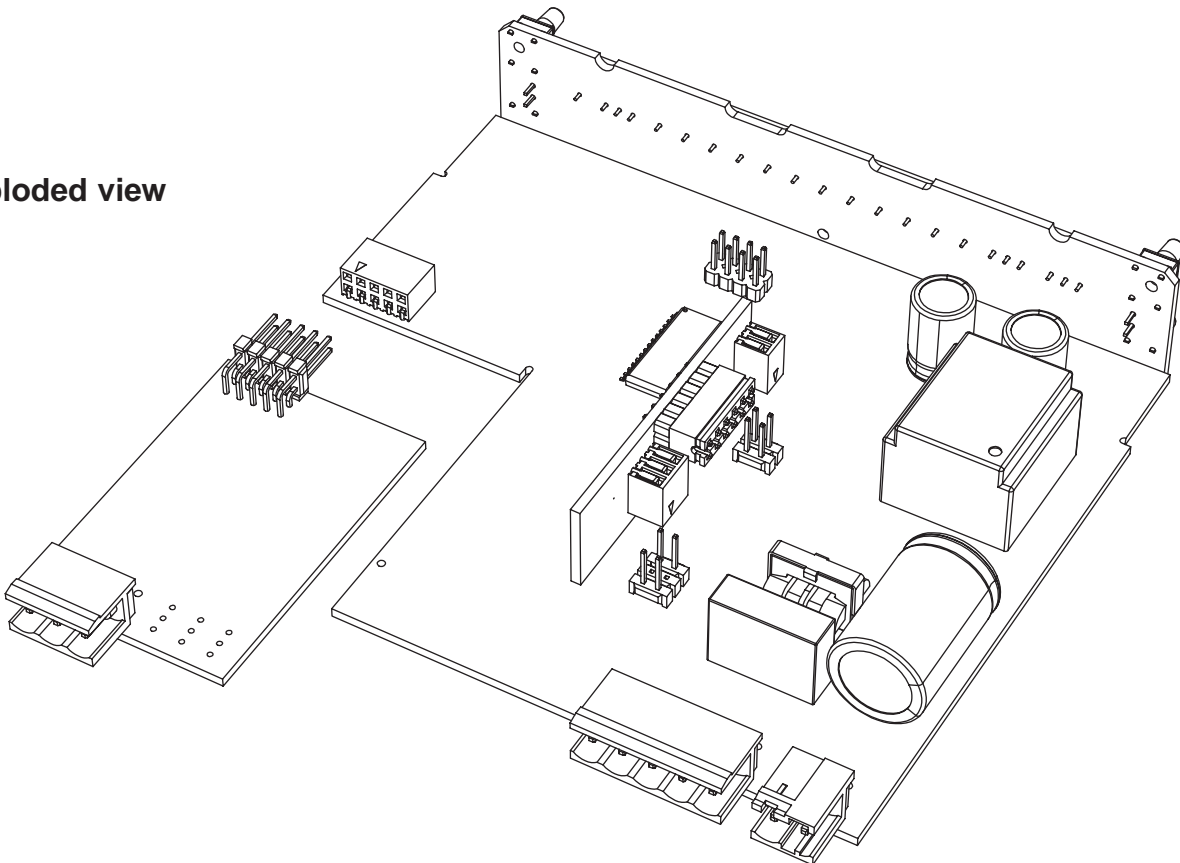

## Standard Display Mode Calibration Procedure



Standard Display with  
Jumper Clips in OFF  
position

**Standard or Center Zero Display Mode** may be selected, depending on the Operating Mode selected. If the standard display mode is not already selected open the meter case as showing on page 4 and move the jumper clips on the display mode select header to the OFF position.

### STEP A REVIEW THE INPUT MODULE STATUS

- 1) See pages 15 – 21 for information on input modules that may be used with this meter.
- 2) Confirm that the correct range and input is selected on the input signal conditioning module.

**Note:** When undertaking an initial set up and primary scaling and calibration of the meter it is best to start with a reset of the scaling.

### STEP B RESET THE SCALING

- 1) Apply power to the meter and press the ZERO and SPAN buttons simultaneously for 2 seconds. This erases any previously memorized scalings, and resets the scaling to the factory default, of approximately zero to full scale, for an input, that is 0 to 100% of the range selected on the input signal conditioner.

Reset the scaling to the default value on by pressing the Zero and Span buttons simultaneously for 2 secs.

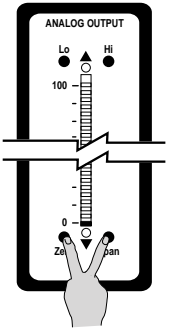

## Two Point Quickset Scaling and Calibration Procedure (continued)

**Note:** To calibrate the bargraph you must be able to input two input signals. Usually the minimum input (LO Input) and the maximum input (HI Input) signals are used for optimum accuracy. However a scaling can be accomplished with any two signals that are higher or lower than each other by more than 5% of fullscale and are not greater than +2.1VDC or less than -1.05VDC.

### STEP C SET THE LOW INPUT SIGNAL READING ON THE BAR

- 1) Apply the LO input signal (4ma in this example) to the input pins.
- 2) Using the ZERO button adjust the bar down to the required position.

Apply 4 mA to the Input Pins and adjust bar display to the required position

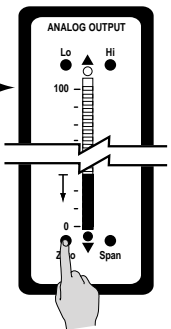

### STEP D SET THE HIGH INPUT SIGNAL READING ON THE BAR

- 1) Apply the high input signal (20mA in this example) to the input pins. Using the SPAN button adjust the bar to the required position. This position could be higher or lower than the position adjusted in Step 2. The scaling for an input of 4 to 20mA is now complete.

Apply 20 mA to the Input Pins and adjust bar display to the required position

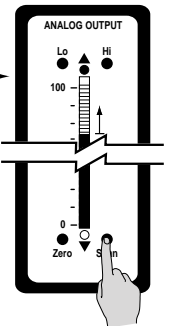

## One Point Quickset Rescaling and Calibration Procedure

### ONE POINT RECALIBRATION

As explained earlier, the FL-B101Q bargraph is calibrated using two point calibration. Once a bargraph is calibrated, the low end of the range may be then recalibrated without affecting the calibration of the high end, and vice versa.

For example, take an FL-B101Q that has been calibrated to read zero to full scale for an input of 4 to 20mA. If now the scaling has to be changed to read zero to full scale for an input of 0 to 20mA, only the low (4 mA) end needs to be recalibrated. The high (20 mA) end of the scaling is left untouched, and so does not change. The following one point recalibration procedure is used for this purpose.

### STEP A RECALIBRATE THE LOW INPUT SIGNAL READING ON THE BAR

- 1) Apply the LO input signal (0ma in this example) to the input pins. The first segment will flash, indicating an under range condition.
- 2) Using the ZERO button adjust the bar up to the required position.
- 3) The FL-B101Q has now been recalibrated to read zero to fullscale for a 0 to 20 mA input.

Apply 0 mA to the Input Pins and adjust bar display to the required position

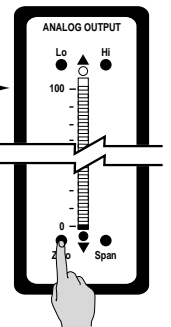

## Center Zero Mode Scaling For Bipolar Inputs

The procedure for scaling the bar graph for bipolar signals is very simple. If say CH1 has to be scaled for -1V to +1V, the steps are as follows:

### STEP A SELECT THE CENTER ZERO DISPLAY MODE FOR CH1

- 1) Following the instructions on page 4, remove the meter from the case.
- 2) Select the Center Zero Mode for CH1 by repositioning the jumper clip on the Center Zero Display Mode Select Header.

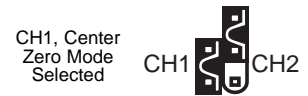

### STEP B REVIEW THE INPUT MODULE STATUS

- 1) See pages 15 – 21 for information on input modules that may be use with this meter.
- 2) Only the IDP4 Universal Input module can be used for dual inputs and information on this module can be found on page 15.
- 3) Confirm that the correct range and input is selected on the input signal conditioning module.

**Note:** When undertaking an initial set up and primary scaling and calibration of the meter it is best to start with a reset of the scaling.

### STEP C RESET THE SCALING ON CHANNEL ONE

- 1) Apply power to the meter and press the CH1 ZERO and CH1 SPAN buttons simultaneously for 2 seconds. This erases any previously memorized scalings, and resets the scaling to the factory default, of approximately zero to full scale, for an input, that is 0 to 100% of the range selected on the input signal conditioner.

Reset the scaling to the default value on by pressing the Zero and Span buttons simultaneously for 2 secs.

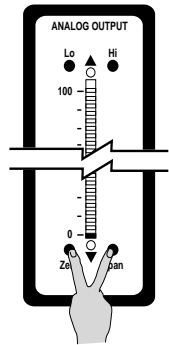

### STEP D SET THE LOW INPUT SIGNAL READING ON THE BAR

- 1) Apply the LO input signal (-1V in this example) to the CH1 input pins.
- 2) Using the CH1 ZERO button adjust the bar down to the required position. In this case, all the bar segments from mid point down to the bottom will be ON.

Apply -1V to the Input Signal Pins and adjust bar display to the required position

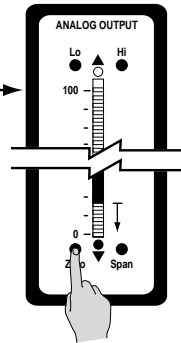

### STEP E SET THE HIGH INPUT SIGNAL READING ON THE BAR

- 1) Apply the high input signal (+1V in this example) to the CH1 input pins.
- 2) Using the CH1 SPAN button adjust the bar to the required position. This position could be higher or lower than the position adjusted in Step 2. In this case, all the bar segments from mid point up to the top will be ON.
- 3) The scaling of CH1 for an input of -1V to +1V is now complete.

Apply +1V to the Input Signal Pins and adjust bar display to the required position

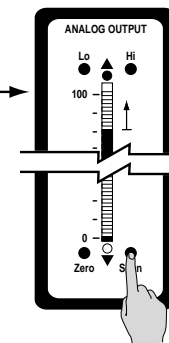

## Analog Output Scaling and Calibration

When the optional analog output module is installed, an independently calibrated 16 bit isolated, voltage or current analog output is available. **The analog signal is independently scaled to the input signal and not to the bargraph display.** It is important to note that the Analog Output is completely independently of the bargraph display. This means for example that the bargraph display may be scaled to go from zero to full scale as the input changes from 0 to 5V, while at the same time, the analog output is scaled to go from 4 to 20mA as the input changes from 2 to 3V. Rescaling the bargraph or the analog output will not affect the scaling of the other.

To calibrate the Analog Output you must be able to input two input signals. Usually the minimum input (LO Input) and the maximum (HI Input) signals are used for maximum accuracy.

For example: the three steps to obtain an Analog Output of 4mA to 20mA for an input of 0 to 10V are:

### STEP A RESET THE ANALOG OUTPUT SCALING

- 1) Press the LO and HI buttons simultaneously and hold them down for 2 seconds. This will reset the analog output scaling to the default value. The default analog output scaling is approximately 0 to 20mA (0 to 10V if voltage output option is selected) for an input that is 0 to 100% of the range selected on the input signal conditioner.

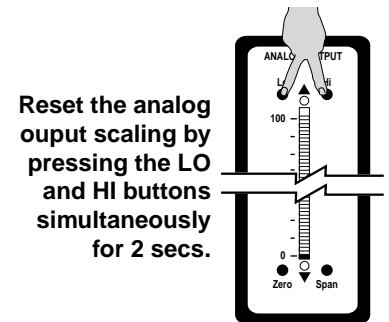

### STEP B CALIBRATE ANALOG OUTPUT FOR LO SIGNAL

- 1) Apply the low input signal (0V in this example) to the meter.
- 2) Connect an external multimeter to the analog output pins (Pins 17 and 18).
- 3) Using the LO button adjust the analog output as measured on the external multimeter to be the required value. (4mA in this example). When the LO button is pressed, the UP or DOWN indicator LED shows the direction of change. To reverse the direction of change release the LO button and press down again. Initially the output changes very slowly, but speeds up as the LO button remains pressed down. The analog output for a low input can be set in this step to any value in the range of 0 to 20mA or 0 to 10V (if the voltage output option is selected).

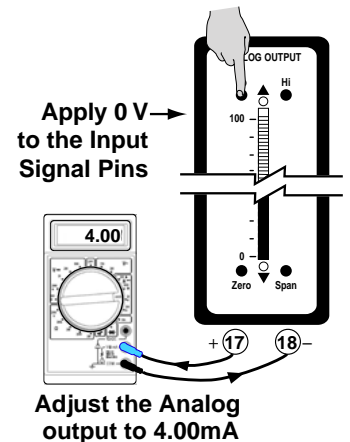

### STEP C CALIBRATE ANALOG OUTPUT FOR HI SIGNAL

- 1) Next apply the high input signal (10V in this example) to the meter.
- 2) Using the HI button, adjust the analog output as measured on the external multimeter to be the required value. (20mA in this example). When the HI button is pressed the UP or DOWN indicator LED shows the direction of change. Release the HI button and press again to reverse the direction of change. Initially the output changes very slowly, but speeds up as the HI button continues to remain pressed. This output may be higher or lower than the value set in Step 2, and may be any value in the range of 0 to 20mA or 0 to 10V. This allows the easy reversal of analog output that is required in some applications.

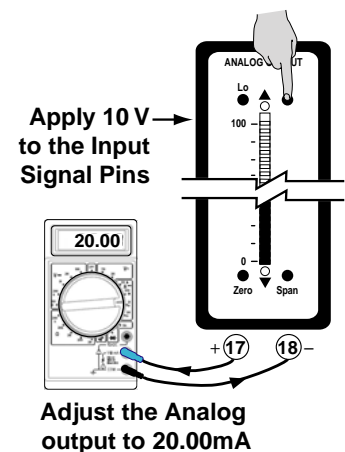

# Functional Diagram

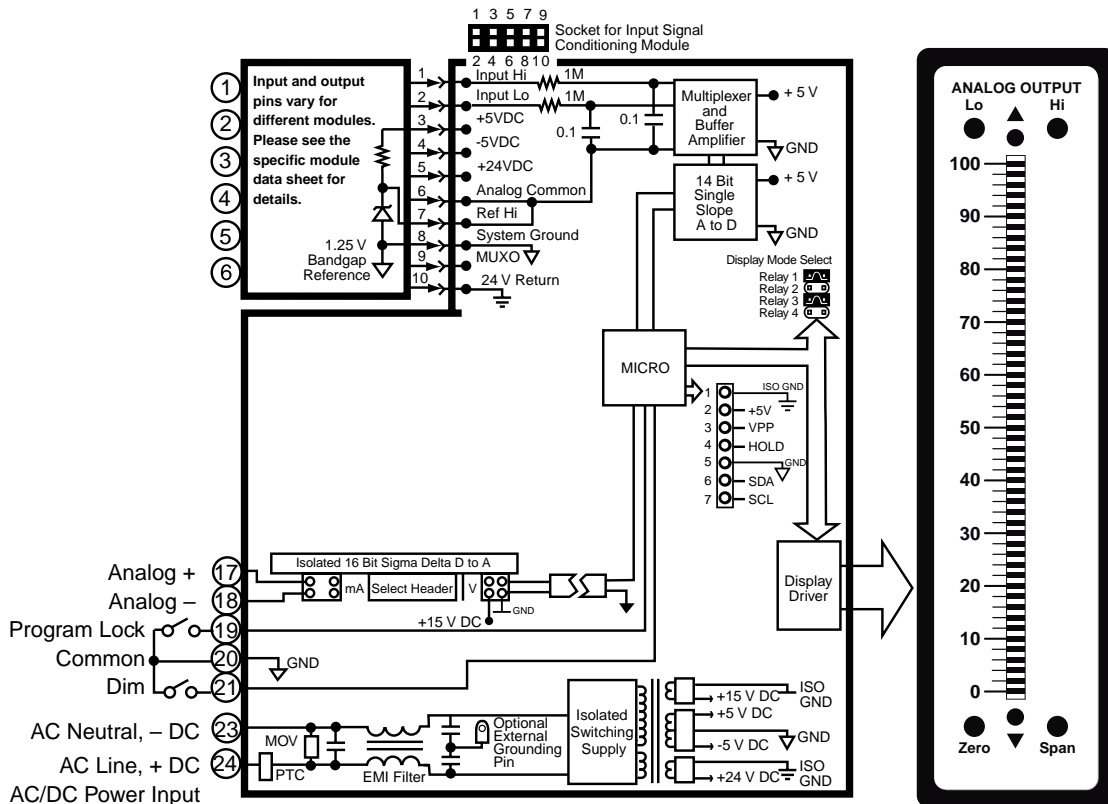

FX-B101Q Functional Diagram

## Connector Pinouts

This meter uses plug-in type screw terminal connectors for all input and output connections. The power supply connections (pins 23 and 24) have a unique plug and socket outline to prevent cross connection. The main board uses standard right-angled connectors. Replacement 2-, 3-, and 4-pin plug connectors are available (see Accessories on page 16).

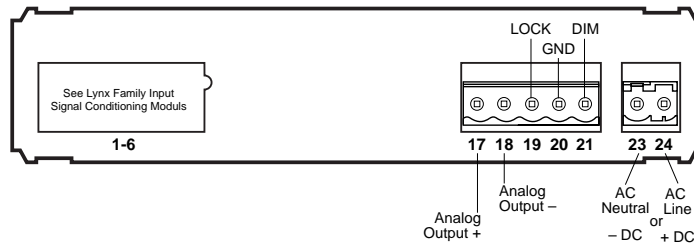

**WARNING**  
AC and DC power supply voltages are hazardous. Make sure the power supply is isolated before connecting to the meter.

## Pin Descriptions

### Input Signal – Pins 1 to 6

Pins 1 to 6 are reserved for the input signal conditioner. See the data sheet for the selected input signal conditioner.

### Pins 17 to 21 – Rear Panel Switches

- Pin 17 ANALOG OUTPUT (+).** mA (0 to 20 mA/4 to 20 mA) or V (0 to 10 V) output is header selectable.
- Pin 18 ANALOG OUTPUT (-).** mA (0 to 20 mA/4 to 20 mA) or V (0 to 10 V) output is header selectable.
- Pin 19 PROGRAMMING LOCK.** By connecting the LOCK pin to the COMMON pin, the meter's programmed parameters can be viewed but not changed.
- Pin 20 COMMON.** To activate the LOCK or DIM functions from the rear of the meter, the respective pins have to be connected to the COMMON pin. This pin is connected to the internal power supply ground.
- Pin 21 DIM.** By connecting the display dim (DIM) pin to the COMMON pin, the display brightness setting is halved.

### Pins 23 and 24 – AC/DC Power Input

Auto-sensing AC/DC power supply. For voltages between 85-265 V AC / 95-370 V DC (PS1) or 18-48 V AC / 10-72 V DC (PS2).

- Pin 23 AC Neutral / -DC.** Neutral power supply line.
- Pin 24 AC line / +DC.** Live power supply line.

### Internal Function Header Pin out

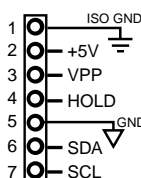

Internal header pins 1, 2, 3, 6, and 7 are for factory settings only. Not for external use!

**4 HOLD.** By connecting the HOLD pin to the GND pin, the displayed reading is frozen, however, A/D conversions continue. When the HOLD pin is disconnected from the GND pin, the correct reading is displayed.

**5 GND.** This pin is connected to the internal power supply ground.

# Component Layout

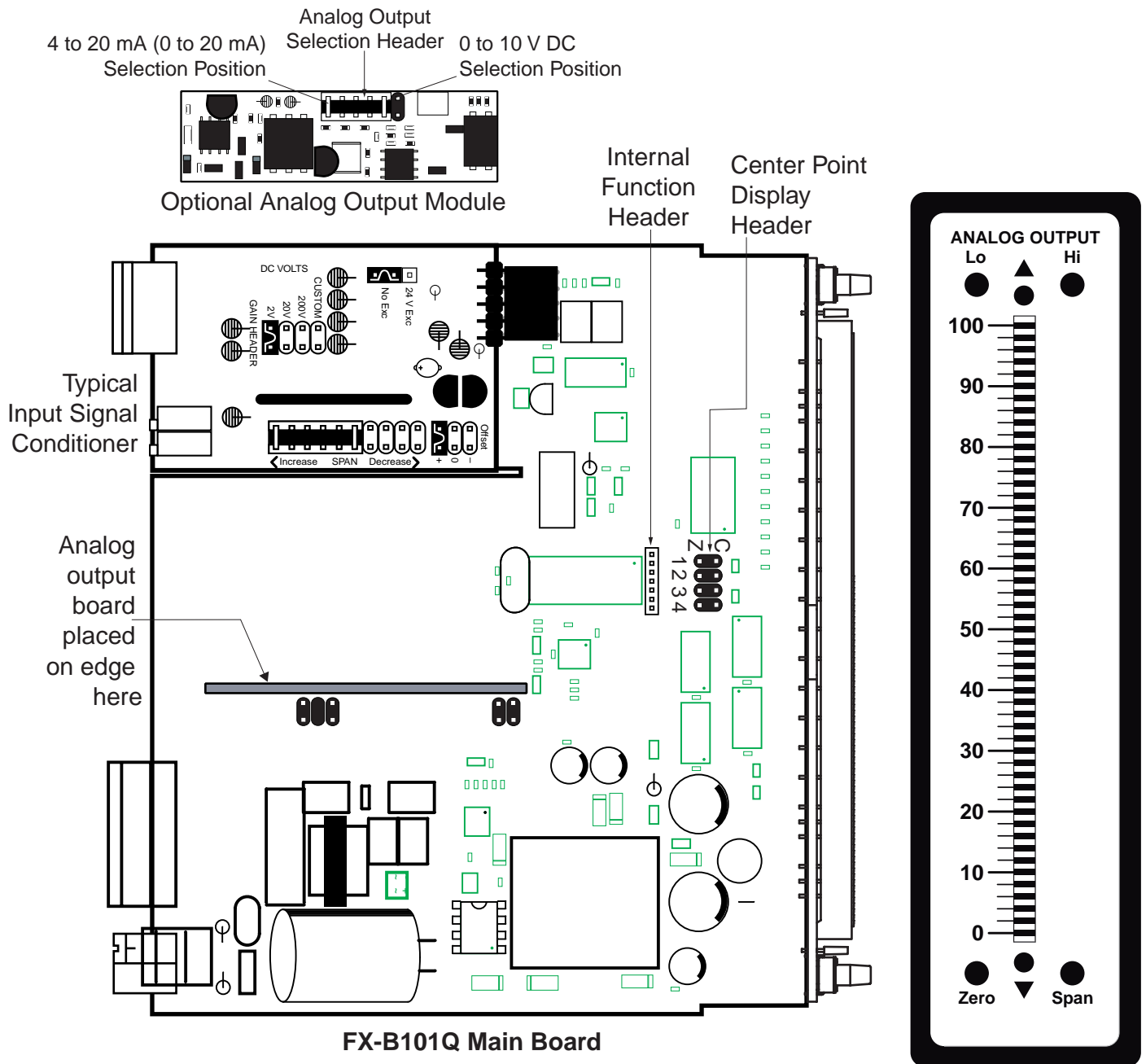

# Connectors

Standard plug-in screw terminal blocks provided by Texmate:



## WARNING

AC and DC input signals and power supply voltages can be hazardous. Do Not connect live wires to terminal blocks, and do not insert, remove or handle terminal blocks with live wires connected.

**Input Power Screw Terminal Plug**  
Part Number: 93-PLUG2P-DP

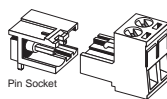

**Right-angled Screw Terminal Plug**  
Part Numbers: 93-PLUG2P-DR...2 pins  
93-PLUG3P-DR...3 pins 93-PLUG5P-DR...5 pins  
93-PLUG4P-DR...4 pins 93-PLUG6P-DR...6 pins

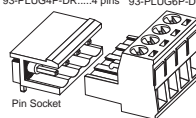

**Straight-thru Input Power Screw Terminal Plug**  
Part Number: 93-PLUG2P-SP

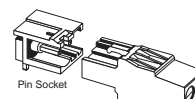

**Straight-thru Screw Terminal Plug**  
Part Numbers: 93-PLUG2P-DS...2 pins  
93-PLUG3P-DS...3 pins  
93-PLUG4P-DS...4 pins

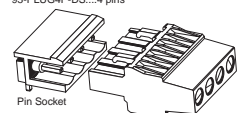









# I-Series Input Signal Conditioning Modules

Many additional input modules are available and others are constantly being developed. Check with your local distributor or [www.texmate.com](http://www.texmate.com) for updated information.

Precalibrated **I-Series** input modules, that have span or zero potentiometers, can be interchanged between any **I-Series** compatible meter, without recalibration, because all of the analog scaling and reference circuitry is self-contained within the module. Where appropriate, all the standard ranges shown are designed to be header selectable by the user, and Texmate's unique SPAN ADJUST Header facilitates scaling to almost any required engineering unit. See Input Module Component Glossary and Calibration on pages 6 and 8.

Unless otherwise specified Texmate will ship all modules precalibrated with factory preselected ranges and/or scalings as shown in **BOLD** type. Other precalibrated standard ranges or custom ranges may be ordered. Factory installed custom scaling and other custom options are also available (see Ordering Information, Special Options on last page).

Symbols Indicate Module Compatibility Within Meter Families		
 TIGER Family	 TIGER Family	 TIGER Family
 LEOPARD Family	 LEOPARD Family	 LEOPARD Family
 LYNX Family	 LYNX Family	 LYNX Family
<b>ALL MODELS</b>	<b>SOME MODELS</b>	<b>MODEL SPECIFIC</b>

IA03: AC Milliamps Scaled RMS, 2/20/200mA AC

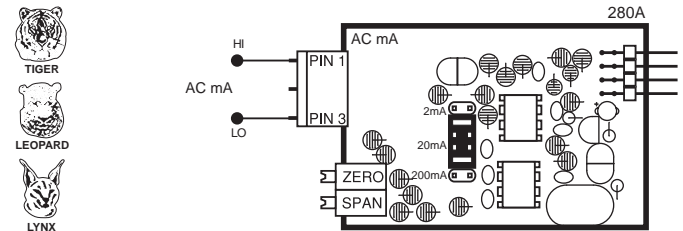

IA01: AC Volts Scaled RMS, 200/600V AC

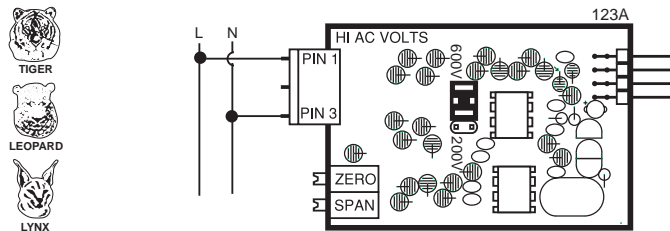

IA04: AC Amps Scaled RMS, 1 Amp AC

IA05: AC Amps Scaled RMS, 5 Amp AC

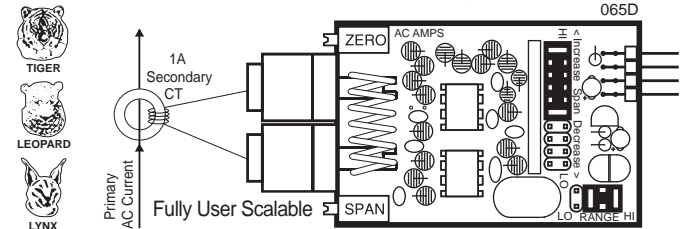

IA02: AC Volts Scaled RMS, 200mV/2V/20V AC

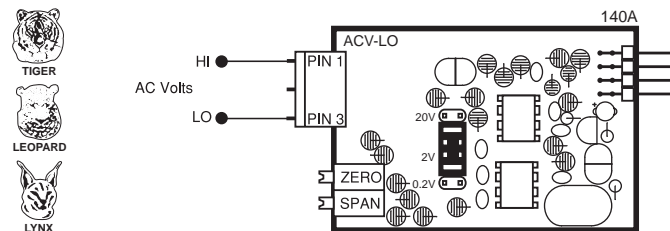

IA06: AC Volts True RMS, 300/600V AC

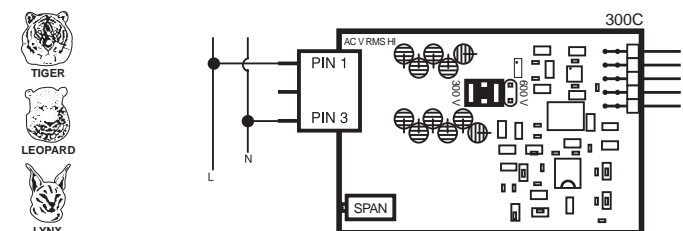

IA07: AC Volts True RMS, 200mV/2V/20V AC

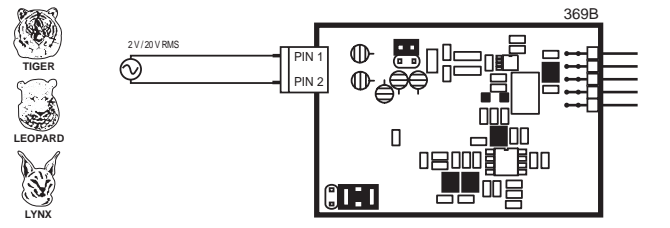

ID02: DC Millivolts, 20/50/100/200mV DC w/24V DC Exc

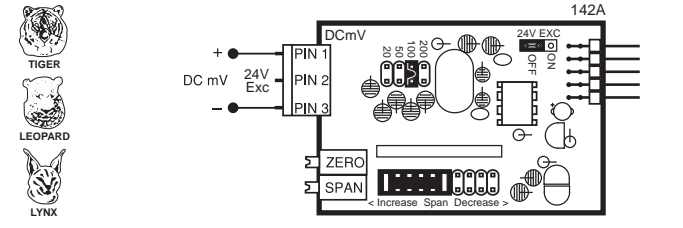

IA08: AC Milliamps True RMS, 2/20/200mA AC

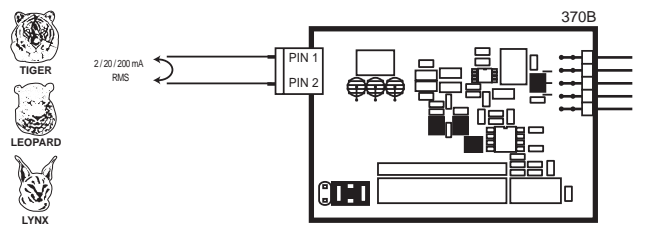

ID03: DC Milliamps, 2/20/200mA DC w/24V DC Exc

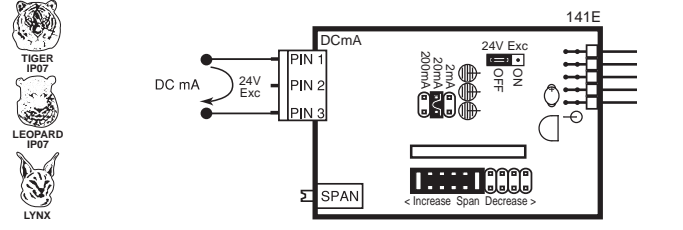

# I-Series Input Signal Conditioning Modules Continued

IA09: AC Amps True RMS, 1 Amp AC  
 IA11: AC Amps True RMS, 5 Amp AC

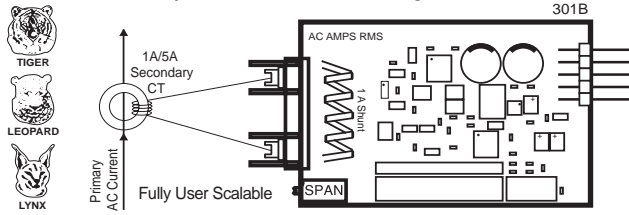

ID07: DC Milliamps, 2/20/200mA DC with Offset and 24V Exc

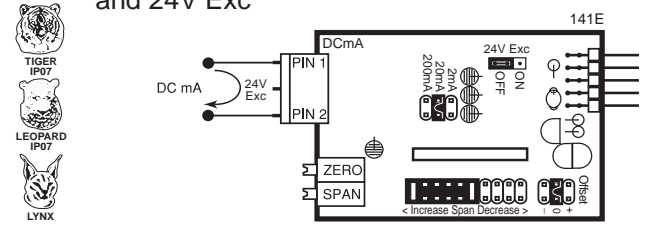

IA10: AC Millivolts, Scaled RMS, 100mV AC

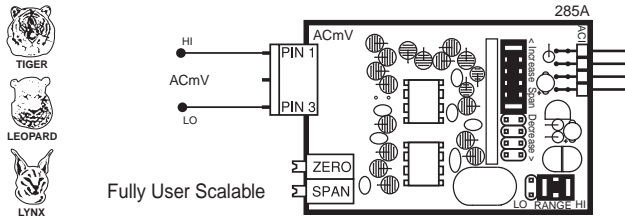

IF02: Line Frequency

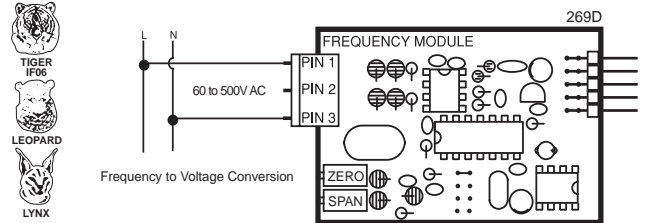

IA12: AC Millivolt RMS Sigma Delta

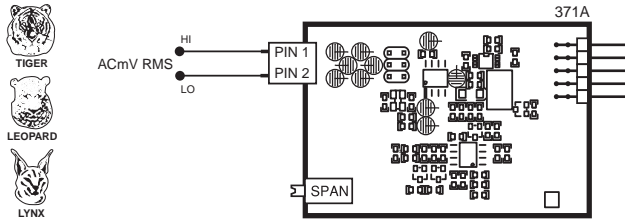

IGYZ: Universal Direct Pressure (Absolute or Differential/Gage)  
 See below for ordering code options

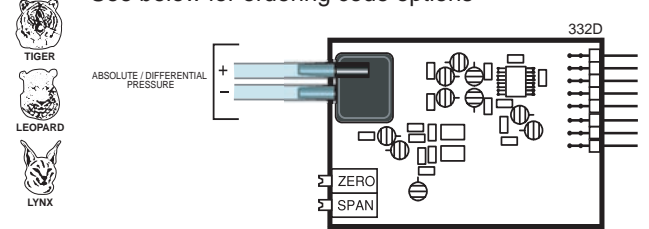

ID01: DC Volts, 2/20/200V/Custom w/24V DC Exc

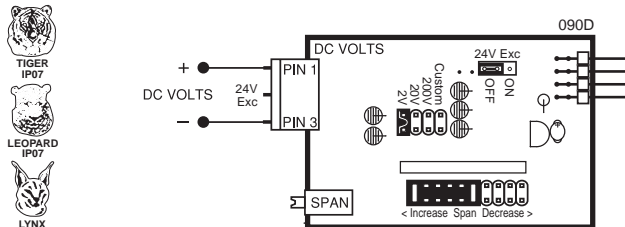

Ordering Code Options for Direct Pressure (IGYX, IGYV & IGYZ)

Sensor Range	CH1 Order Code	CH2 Order Code
1 psi Absolute	A	A
1 psi Differential	B	B
5 psi Absolute	C	C
5 psi Differential	D	D
15 psi Absolute	E	E
15 psi Differential	F	F
30 psi Absolute	G	G
30 psi Differential	H	H
100 psi Absolute	J	J
100 psi Differential	K	K

For Single Channel IGYX with two digital inputs, the last digit of order code is always X.

For Universal Direct Pressure IGYZ, the last digit of order code is always Z.

ID04: DC Amps, 5A DC  
 ID09: DC Amps, 1A DC

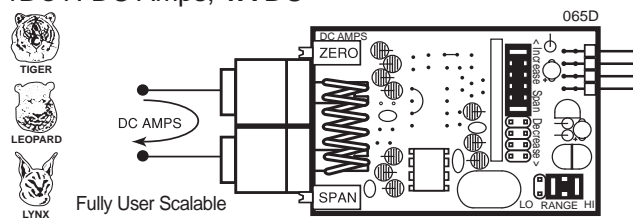

IPO1: Process Loop, 4-20mA  
 IPO2: Process Loop, 4-20mA with 24VDC EXC

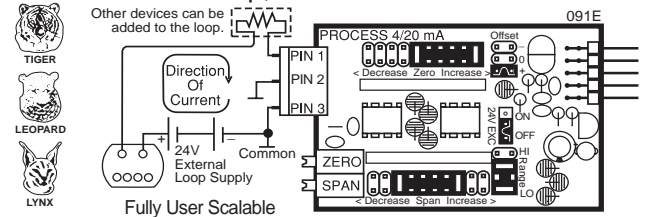

ID05: DC Volts 2/20/200/Custom V DC with Offset and 24V Exc.

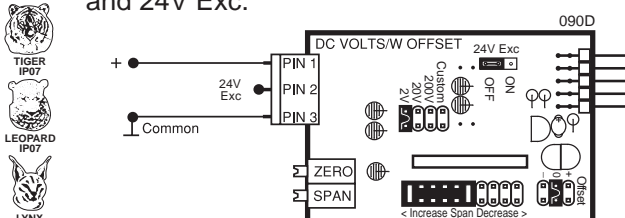

IPO3: Process Input, 1-5V DC with Offset, 24V Exc

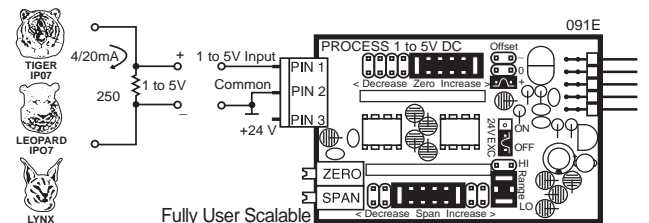

# I-Series Input Signal Conditioning Modules Continued

**IP07: Universal Process Input**  
 2V/5V/10V/20V/200V/2mA/20mA/Custom

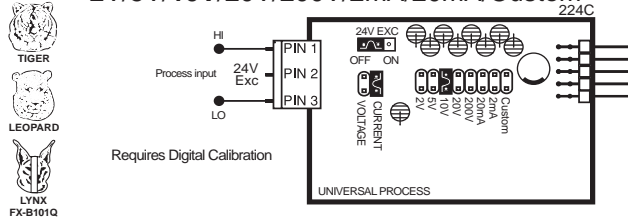

**IR02: 3 wire Potentiometer 1K min (0-F.S.)**

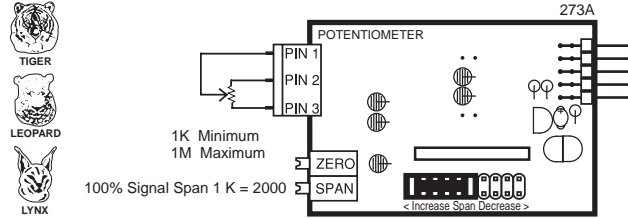

**IR03: Linear Potentiometer 1KΩ min**

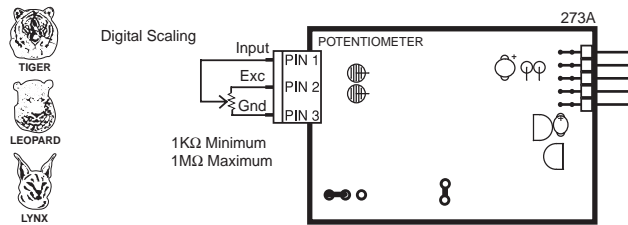

**IR04: Resistance 2KΩ (Lynx only)**  
**IR05: Resistance 2KΩ (Leopard only)**

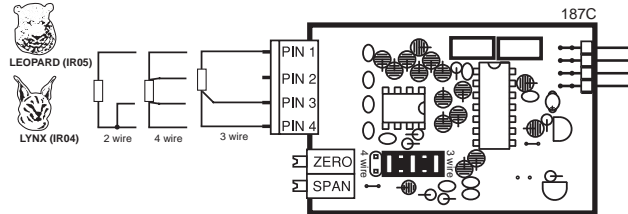

**IS05: Pressure/Load Cell 20/2mV/V, 5/10V Exc 4-wire**

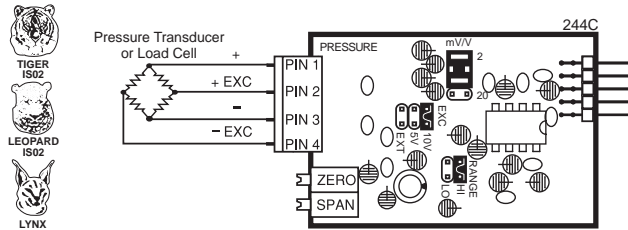

**IS06: Pressure/Load Cell Ext Exc., 20/2mV/V, 4-wire**

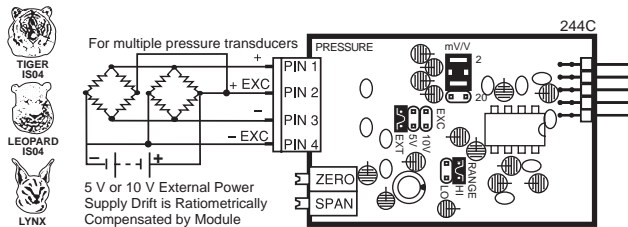

**IT03: RTD, 100 Pt. 2/ 3/4-wire (-200 to 800°C)**  
**IT04: RTD, 100 Pt. 2/ 3/4-wire (-200 to 1470°F)**  
**IT05: RTD, 100Ω Pt. 2/3/4-wire (-199.9 to 199.9°F)**  
**IT14: RTD, 100Ω Pt. 2/3/4-wire (-199.9 to 199.9°C)**

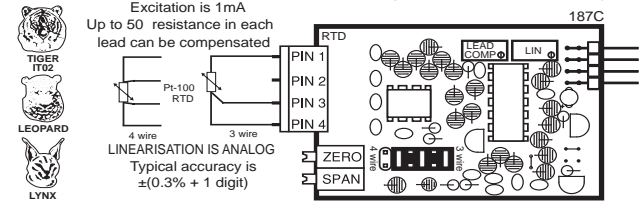

**IT06: Thermocouple, J Type (0-1400 °F)**  
**IT08: Thermocouple, J Type (0-760 °C)**

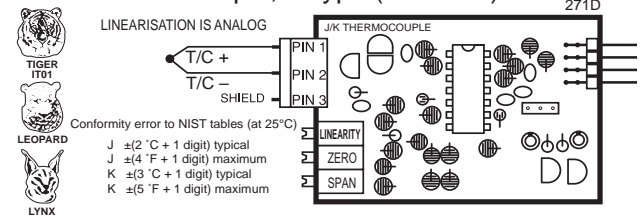

**IT07: Thermocouple, K Type (0-1999 °F)**  
**IT09: Thermocouple, K Type (0-1260 °C)**

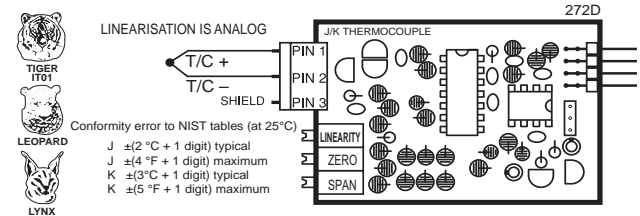

The websites for all measurement and control solutions

**Search by Application**  
Using Inputs, Outputs, Type and Function. Locate applicable products and view downloadable application notes online.

**Search by Input Signals**

**Search by Case Size**

**Search Entire Site by Key Words**

**Search by Product Family**

**Find any Data Sheet**

**View data sheets online**  
Flip the pages, enlarge any pages and print from your Browser, or download the complete data sheets as PDF files

Meter Series:	View online	Pdf format
Tiger-Series	Select Datasheet:	Select Datasheet:
Leopard-Series	Select Datasheet:	Select Datasheet:
Lynx-Series	Select Datasheet:	Select Datasheet:
Application Specific	Select Datasheet:	Select Datasheet:

**Get Prices On Line**

Dual input modules, and those modules exclusively compatible with the Leopard or Tiger Families, do not have zero and span adjustments. These modules are scaled and calibrated using the internal software functions of each individual meter.

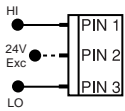

### Input and Output Pins

On most modules Pin 1 is the Signal High input and Pin 3 is the Signal Low input. Typically Pin 2 is used for Excitation Voltage output.

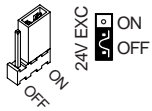

### 24 V DC Output for 4-20 mA Header

On some modules this header enables a 24 V DC 25 mA (max) Excitation/Auxiliary output to be connected to Pin 2 that can power most 4-20 mA process loop sensors.

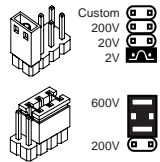

### INPUT RANGE Headers

Range values are marked on the PCB. Typically two to eight positions are provided, which are selected with either a single or multiple jumper clip. When provided, a custom range position is only functional when the option has been factory installed.

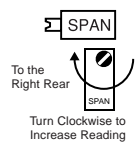

### SPAN Potentiometer (Pot)

If provided, the 15 turn SPAN pot is always on the right side (as viewed from the rear of the meter). Typical adjustment is 20% of the input signal range.

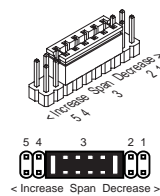

### SPAN ADJUST Header

This unique five-position header expands the adjustment range of the SPAN pot into five equal 20% steps, across 100% of the input Signal Span. Any input Signal Span can then be precisely scaled down to provide any required Display span from full scale to the smallest viewable unit.

SPAN Adjust Header position	1	2	3	4	5
SPAN Pot %	20%	20%	20%	20%	20%
Signal Span %	20%	40%	60%	80%	100%

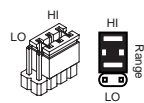
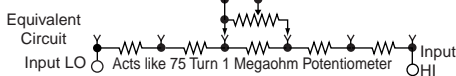

### SPAN RANGE Header

When this header is provided it works in conjunction with the SPAN ADJUST Header by splitting its adjustment range into a Hi and a Lo range. This has the effect of dividing the adjustment range of the SPAN pot into ten equal 10% steps across 100% of the input Signal Span.

SPAN Adjust Header position	Span Adjust Header					Span Range Header				
	1	2	3	4	5	1	2	3	4	5
SPAN Pot %	10%	10%	10%	10%	10%	10%	10%	10%	10%	10%
Signal Span %	10%	20%	30%	40%	50%	60%	70%	80%	90%	100%

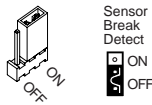
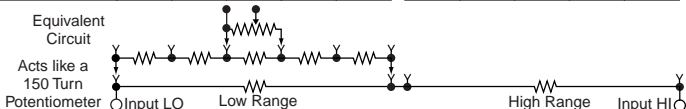

### Function Select Headers

On some modules various functions such as Amps and Volts, 4 wire and 6 wire, or cold junction compensation are selected by header positions that are marked on the PCB.

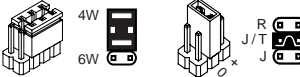

### Excitation Output Select Headers

When excitation outputs are provided, they are typically 5 V DC max 30 mA, 10 V DC max 30 mA (300Ω or higher resistance) or external supply. They are selected by either a single or multiple jumper clip.

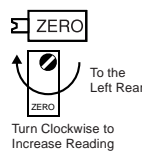

### ZERO Potentiometer (Pot)

If provided, the ZERO pot is always to the left of the SPAN pot (as viewed from the rear of the meter). Typically it enables the input signal to be offset ±5% of the full scale display span.

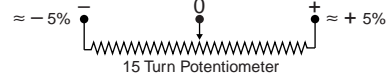

### ZERO OFFSET RANGE Header

When provided, this three position header increases the ZERO pot's capability to offset the input signal, by ±25% of the full scale display span. For example a Negative offset enables a 1 to 5 V input to display 0 to full scale. The user can select negative offset, positive offset, or no offset (ZERO pot disabled for two step non-interactive span and offset calibration).

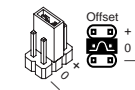

Zero Offset Range Header		
NEGATIVE OFFSET Decreases Digital Reading	0	POSITIVE OFFSET Increases Digital Reading
ZERO Pot %	- 100% of Offset	+ 100% of Offset
Offset Range	≈ - 25%	≈ + 25%

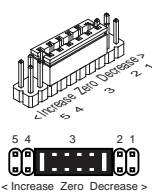
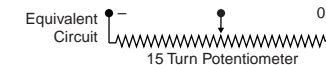

### ZERO ADJUST Header

When this header is provided, it works in conjunction with the ZERO OFFSET RANGE Header, and expands the ZERO pot's offset capability into five equal negative steps or five equal positive steps. This enables virtually any degree of input signal offset required to display any desired engineering unit of measure.

ZERO Adjust Header Position	Zero Adjust Header NEGATIVE OFFSET					Zero Adjust Header POSITIVE OFFSET				
	5	4	3	2	1	1	2	3	4	5
ZERO Pot Span	6400	6400	6400	6400	6400	6400	6400	6400	6400	6400
Offset Range	-25200 to -31600	-18900 to -25300	-12600 to -19000	-6300 to -12700	0 to -6400	0 to +6400	+6300 to +12600	+12600 to +18900	+18900 to +25200	+25200 to +31600

CALIBRATE position, Zero Pot disengaged (no offset applied)

Tiger, Leopard and Q-Series Lynx meters have software calibration and scaling functions that can expand or be used in conjunction with the analog capabilities of any compatible modules.

**Note:** I-Series modules with analog calibration and scaling capability can be interchanged between any compatible meter without recalibration. However, meters that also have software scaling and calibration capabilities such as meters in the Leopard and Tiger families or Lynx Q-Series (Quickset programming), must have their software scaling set to unity gain.

### Basic standard range calibration of direct reading modules that utilize either Auto Zero or a ZERO pot, an INPUT RANGE Header and or a SPAN pot.

- 1 If the module has an INPUT RANGE Header, reposition the jumper clip to select the desired input signal range.
2. Apply a zero input or short the input pins. The display will auto zero, or if the module has a ZERO pot, it should be adjusted until the display reads zero.
- 3 Apply a known input signal that is at least 20% of the full scale input range and adjust the SPAN pot until the display reads the exact input value. The Lynx family of Q meters can accept negative signals also, and may be scaled for inputs from -50% to +100% of the range selected on the input signal conditioning module.

### Wide range scaling, in engineering units not requiring offsets, with modules that utilize auto-zero or a ZERO pot, a SPAN RANGE Header and or a SPAN ADJUST Header.

Texmate's unique SPAN ADJUST and SPAN RANGE Headers provide the circuit equivalent of an ultra-precision one megohm 75 or 150 turn potentiometer that can infinitely scale down any Input Signal SPAN to provide any Display Span from full scale to the smallest viewable unit.

If the module has an INPUT RANGE Header, and the required full scale Display Span (digital counts or bargraph segments) is to be larger than the directly measured value of the input Signal Span, then the next lower range on the INPUT RANGE Header should be selected. The resulting over range Signal Span is then scaled down, by selecting the position of the SPAN RANGE Header and or the SPAN ADJUST Header, which will reduce the input Signal Span to a percentage, that the required Display Span can be reached by calibration with the SPAN pot.

**Example A:** Using a FX-B101Q bargraph meter

Input signal 0 to 10 V to read zero to full scale.

Signal Span = 10 V, Display Span = 100 segments

- 1 Select the 2 V INPUT RANGE Header position. The standard direct scaling will provide a display of 100 segments with an input of only 2 V which is  $(2 \div 10) = 20\%$  of the examples 10 V Signal Span.
- 2 To scale down the Signal Span to 20% select the 20% Signal Span position on the SPAN ADJUST Header (position 1) or if the module has a SPAN RANGE Header, select (LO Range) and 20% Signal Span position on the SPAN ADJUST Header (position 2).
- 3 Apply a zero input or short the input pins. The display will auto zero, or if the module has a ZERO pot, it should be adjusted until the display reads zero.
- 4 Apply 10 V and adjust the SPAN pot until the display reads full scale.

### Large offset scaling and calibration of process signals with modules that utilize ZERO ADJUST Headers and or ZERO OFFSET RANGE Headers.

Texmate's unique ZERO OFFSET RANGE Header enables the use of a simple two step scaling and calibration procedure for those process signals that require large offsets. This eliminates the back and forth interaction, between zero and span settings, that is often required to calibrate less finely engineered products.

The first step is to set the ZERO OFFSET RANGE Header to the center position (No Offset) and scale down the Input Signal Span to a percentage that will enable calibration with the SPAN pot to reach the required Display Span.

The second step is to set the ZERO ADJUST and or ZERO OFFSET RANGE Header to provide a positive or negative offset so that calibration with the ZERO pot will offset the Display Span to produce the required display reading.

**Example B:** Using a FX-B101Q Bargraph meter.

Input signal 1 to 5 V to read zero to full scale.

Signal Span = 4 V, Display Span = 100 segments

- 1 If the module has an INPUT RANGE Header the 2 V position should be selected. This will provide a display of 101 segments for an input of 2 V which is  $(2 \div 4) = 50\%$  of the examples 4 V signal span. To scale down the Signal Span to 50% select the next higher 60% Signal Span position on the SPAN ADJUST Header (position 3).
- 2 If the module is a Process Input 1-5 V DC type, select the (Hi Range) position on the SPAN RANGE Header and the 100% Signal Span position on the SPAN ADJUST Header (position 5, max increase). This will provide a display of 101 segments for an input of 4 V which is 100% of the examples 4 V Signal Span.
- 3 Set the ZERO OFFSET RANGE Header to the center position (no offset). Apply 1 V and adjust the SPAN pot until the display reads 25 segments. A 4 V input would then read 100 segments.
- 4 Set the ZERO OFFSET RANGE Header to the negative offset position. If the module has a ZERO ADJUST Header select the position that will provide a negative offset of  $\approx 25$  segments. Apply 1 V and adjust the ZERO pot until the display reads zero. Apply 5 V and check that the display reads full scale.

**Example C:** Using a FX-B101Q Bargraph meter

Input signal 4 to 20 mA to read zero to full scale

Signal Span = 16 mA, Display Span = 100 segments

- 1 The full scale Signal Span of the Process Input 4-20 mA modules is 0 to 20 mA for a full scale Display Span of 0 to 100 segments.
- 2 Select the (Lo Range) Position on the Span Range Header and the 70% Signal Span position on the SPAN ADJUST Header (position 2).
- 3 Set the ZERO OFFSET RANGE Header to the center position (no offset). Apply 4 mA and adjust the SPAN pot until the display reads 25 segments. A 16 mA input would then read 100 segments.
- 4 Set the ZERO OFFSET RANGE Header to the positive offset position. If the module has a ZERO ADJUST Header select the position that will provide a negative offset of  $\approx -25$  segments. Apply 4 mA and adjust the ZERO pot until the display reads zero. Apply 20 mA and check that the display reads full scale.

# Standard Face Plates and Scales

Unless otherwise specified, a standard 0-100 scaled face plate with white letters on a black background is provided with each meter. In those cases where a temperature module is ordered, a 0 – 200°F (white on black) face plate will be provided as standard.

Alternatively a face plate with black letters on a white background or a blank, white or black face plate, may be ordered as a no charge substitute. For temperature applications there are also several different optional face plates that may be ordered as a no charge substitute. (See below). Customized face plates with special scaling can also be ordered (see following page).

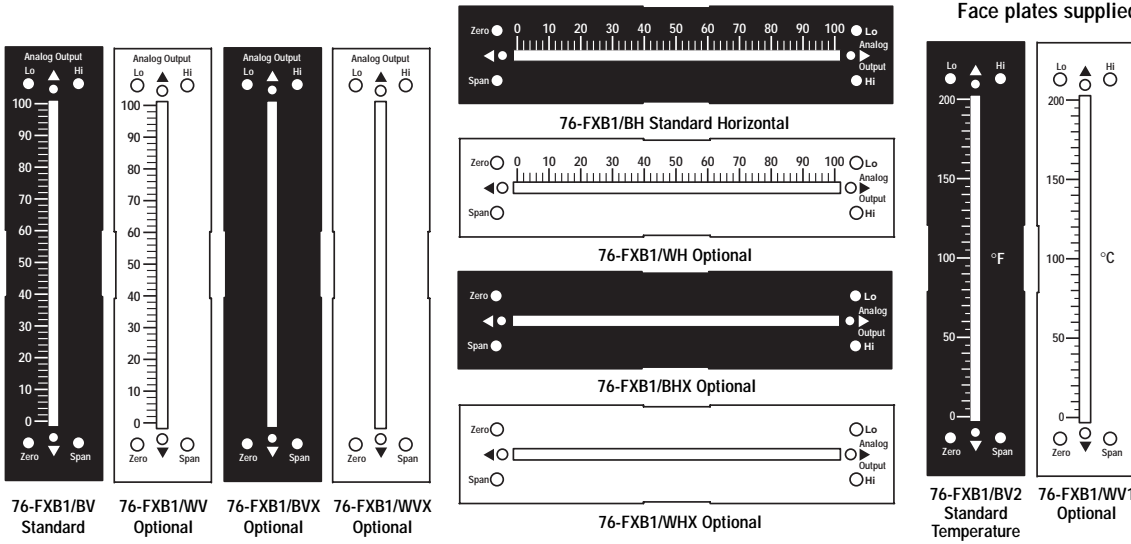

Face plates supplied with temperature modules.

Other optional face plates for temperature are also available in the following ranges:

- 0 to 200
- 0 to 1000
- 200 to +200 (Zero Center Mode)

When ordering, specify white letters on a black background or black letters on a white background. Horizontal or vertical format and °F or °C caption.

# Standard Scales and Caption Sheets (white or black lettering for do-it-yourself customizing)

Clear self-adhesive caption sheets with white or black lettering are provided for each meter shipped with a standard or optional faceplate.

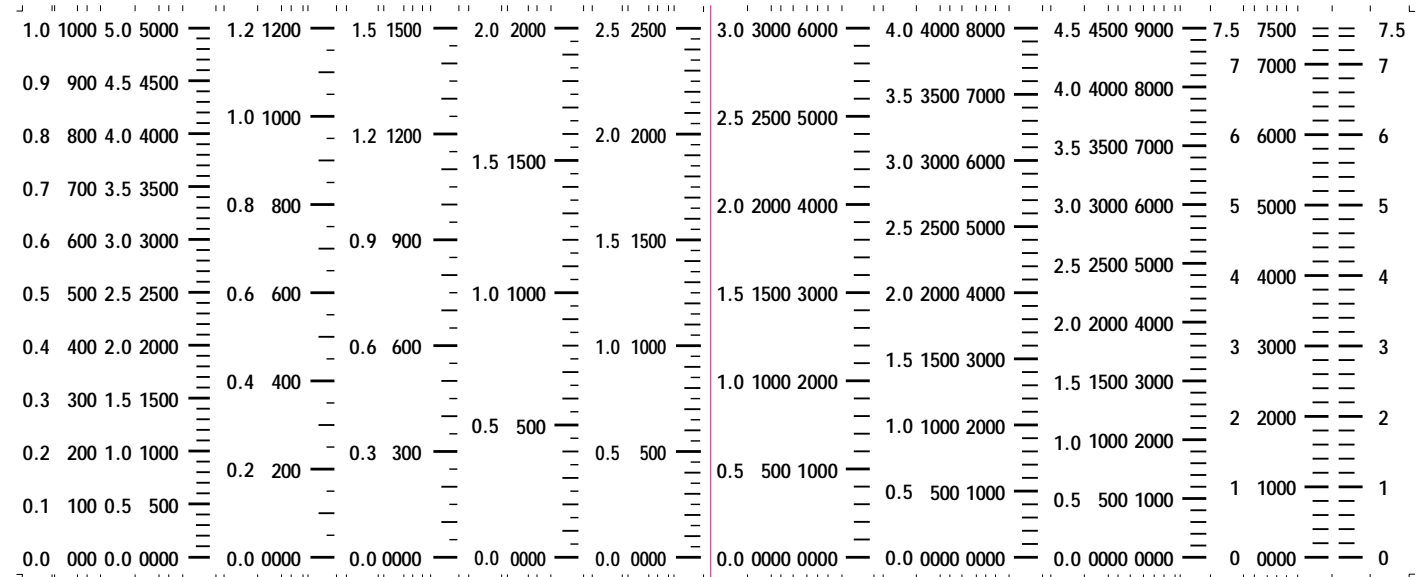

A	AC	E <sub>b</sub>	Btu	bars	CFH	BHP	Low	inch/	CosØ	AMPS	BBL/HR	AHEAD	AC Vars	AC Amperes	AC Kilowatts	AIR PRESSURE	AC Milliampers
J	Ah	kJ	bar	cal <sub>15</sub>	CFM	IPS	High	Kcal	FEET	GALS	BBL/MIN	ALARM	AC Volts	AC Kilovars	AC Millivolts	AC Kiloamperes	Battery Voltage
K	cd	kV	cal	cm <sup>-1</sup>	CFS	IPH	MGD	kg/hr	Hold	INHg	DEG/MIN	BOILER	AC Watts	AC Kilovolts	BPH X 1000	AC Megavars	Backup Voltage
l	dB	kW	cm	cm <sup>2</sup>	COS	Kg/h	Mld	kVAR	Km <sup>3</sup> /h	m/min	FT H <sub>2</sub> O	Cycles	BEARING	AIR FLOW	CFH x 1000	AC Megawatts	Displacement
m	DC	ml	FT <sup>3</sup>	cm <sup>3</sup>	CPH	KPH	MPH	kW/s	MWH	m/sec	In. H <sub>2</sub> O	Depth	COOLANT	BBLs/HOUR	DC Amperes	AC Watts/Vars	DC Amps to Ground
V	FT	NL	lbs	dm <sup>3</sup>	CPM	KPM	MPS	RPM	mWs	Nm <sup>3</sup> /h	Kg/cm <sup>2</sup>	HEATER	DC Volts	BFM AMPS	DC Kilovolts	CENTIMETERS	DC Microamperes
α	HP	Pa	IN <sup>2</sup>	H <sub>2</sub> O	CPS	KPS	N/m <sup>2</sup>	MPM	mbar	Ohms	KNOTS	Height	DC Watts	BHP x 100	DC Kilowatts	DC Kiloamperes	DC Milliampers
β	Hz	PF	kg/	kPa	DCA	kWH	ORP	M <sup>3</sup> /hr	ml/m <sup>3</sup>	PSIA	kg/sec	Hertz	Degrees	BLOWER	DC Millivolts	FD FAN AMPS	GALLONS / MINUTE
φ	Kg	pH	mA	l/s	FPH	lb/ft	PPH	Upm	mm/s	PSID	Mvars	Hours	ENGINE	DC Current	FPM X 100	IN. H <sub>2</sub> O PRESS	GENERATOR AMPS
Ω	kA	sin	mS	l/h	FPM	lb/in	PPM	VAC	Peak	PSIG	mmH <sub>2</sub> O	INCHES	EXHAUST	Dew Point	FPM X 1000	LBS/MINUTE	LBS PER GALLON
Δ	L <sup>3</sup>	t/h	mV	l/m	FPS	LPH	PPS	Vars	PORT	PSIR	mmHg	Input	Humidity	Degrees C	GPM X 1000	LEVEL INCHES	LOAD LIMIT PERCENT
μ	m <sup>3</sup>	yd <sup>3</sup>	Nm	lb/h	GAL	LPM	RPH	VDC	STRB	SCFM	VOLTS	PORT	METERS	Degrees F	HORSEPOWER	LEVEL GALLONS	MANIFOLD PRESSURE
∅	W	μA	oz	MW	GMP	LPS	RPS	w/m <sup>2</sup>	TARE	TORR	%LOAD	PUMP	Output	Degrees K	INCHES WC	LEVEL PERCENT	MILL LOAD AMPS
γ	°C	μS	RH	min	GPH	m <sup>3</sup> /h	phi	YPM	TONS	U/min	%OPEN	Preset	Percent	Degrees R	INCHES H <sub>2</sub> O	MILLIMETERS	MOTOR LOAD AMPS
%	°F	μV	1/h	mm	GPM	m <sup>3</sup> /m	psi	YPS	X100	x10kN	→	Reset	Program	FPM X 10	KILOWATTS	Percent Current	Percent Horsepower
∠	°K	μΩ	μm	Sm <sup>3</sup>	GPS	m <sup>3</sup> /S	X10	μPa	%KW	X1000	←	SHAFT	Pounds	Frequency	LBS X 1000	Percent Load	OXYGEN PERCENT
												SPEED	Pulses	FUEL FLOW	MEGAWATTS	PERCENT OPEN	TEMPERATURE °C
												Setup	RUDDER	GALLONS	Power Factor	RATE OF TURN	TEMPERATURE °F
												TABLE	SPINDLE	IN. WATER	Phase Angle	STEAM TEMP °F	Motor Load Percent
												Total	SO ROOT	LEVEL FT.	RPM X 100	TONS / HOUR	LEFT RIGHT
												VALVE	Set Point	LBS X 100	STARBOARD	OIL PRESSURE	FRONT REAR
												Valley	THRUST	POSITION	TANK LEVEL	WATER LEVEL	FORWARD REVERSE
												WATTS	TURBINE	TONS X 10	VAC MM HG	1000 LBS/HOUR	TOP BOTTOM (L119)

# Custom Face Plates and Scales



## Texmate Produces Thousands of Custom OEM Face Plates

Have Texmate Design and Build a Custom Face Plate to Suit your Next project!

- Custom face plates have a non-recurring artwork charge. A serial number is then assigned to each artwork, to facilitate re-ordering. We prefer custom logos and special artwork to be supplied in an Illustrator or Photoshop file format.
- The non-recurring artwork charge is less if you choose elements from our library. The standard scales and numbers in the library are shown below. The standard library captions are shown on the caption sheet. (page 14)
- Small Run or One-Off custom face plates incur an installation charge, and are generally printed on a special plastic film, which is then laminated to custom faceplate blanks as required.

- Large Run (250 pieces min): custom face plates are production silk screened, issued a part number, and held in stock for free installation as required by customer orders.
- OEMs may also order Custom Meter Labels, Box Labels Custom Data Sheets and Instruction Manuals.

Part Number	Description	List
<b>Small Run Custom Face plates for Bargraphs</b>		
ART-FB-S/L	.NRC for artwork & set-up Faceplate/Library	\$35
ART-FB-S/N	.NRC for artwork & set-up Faceplate/Non-Library	\$55
ART-FB-S/L/C	.NRC for artwork & set-up Faceplate/Library/Co.Logo	\$75
ART-FB-S/N/C	.NRC for artwork & set-up Faceplate/Non-Library/Co.Logo	\$95
ART-FB-001	.Install Faceplate per meter - 1 color	\$10
ART-FB-002	.Install Faceplate per meter - 2 color	\$20
ART-FB-003	.Install Faceplate per meter - 3 color	\$30

Specify artwork serial number when ordering face plate installation. ie: AFB-XXXX

<b>Large Run Custom Face plates for Bargraphs</b>		
ART-FL-001	.Minimum order \$250 (\$250x\$1) - 1 color	\$10
ART-FL-002	.Minimum order \$350 (\$250x\$1.40) - 2 color	\$20
ART-FL-003	.Minimum order \$450 (\$250x\$1.80) - 3 color	\$30

When ordering Large Run Face plates to be installed specify the custom part number issued for each different artwork. ie: 77-FLXXXX

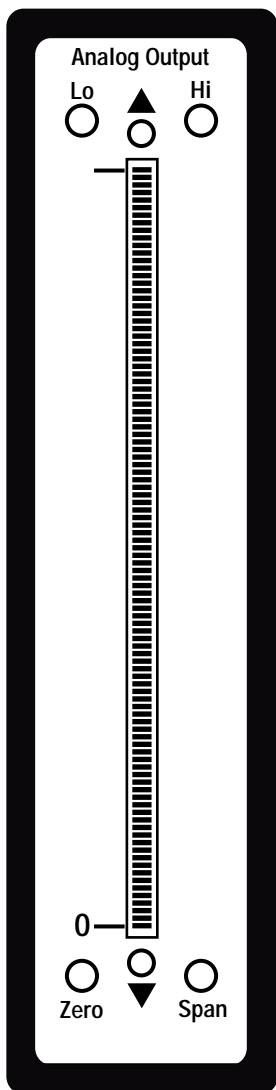

1	1.2	1.5	2	2.5	3	4	4.5	5	6	7.5	8	9
10	12	15	20	25	30	40	45	50	60	75	80	90
100	120	150	200	250	300	400	450	500	600	750	800	900
1000	1200	1500	2000	2500	3000	4000	4500	5000	6000	7500	8000	9000

10	12	15	20	25	30	40	45	50	60	75	80	90
9						35	40	45		70		80
8	10			20	25			40	50		60	70
7		12				30	35			60		70
6			15		20			35			50	60
5	8					25	30		40	50		60
4		9		15				30			50	60
3					20				40	50		60
2	6		10		15	20		25	30		40	50
1		6		10			15			40	50	60
0												

10x5	6x2x2	5x3x2	4x5x2	5x5x2	6x5	8x5	9x5	10x5	6x5	7.5x5	8x5	9x5
Div. 50	24	30	40	50	30	40	45	50	30	37.5	40	45

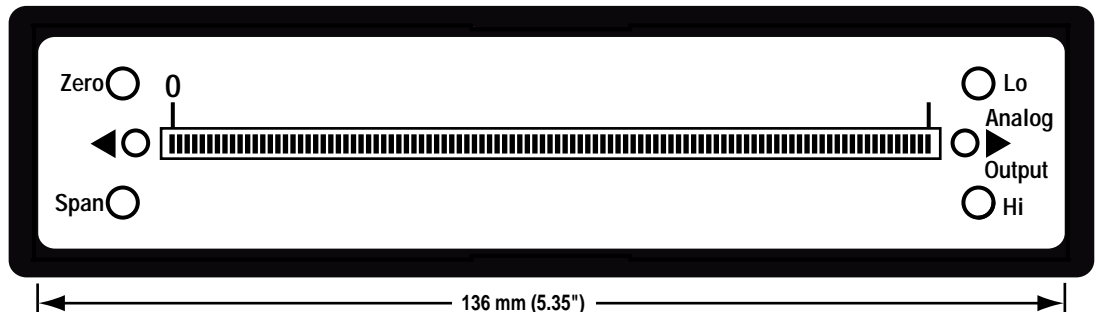

Some horizontal scales only have numbers on each second major division.

Face plate scales and numbers are shown close to their actual size.

**Fits 6" Edgewise Pointer Meter Cut-Outs**

The adapter snaps on the 36x144 mm (1.42"x5.69") case and enables single unit or stack mounting in an existing 6" edgewise pointer meter cut-out.

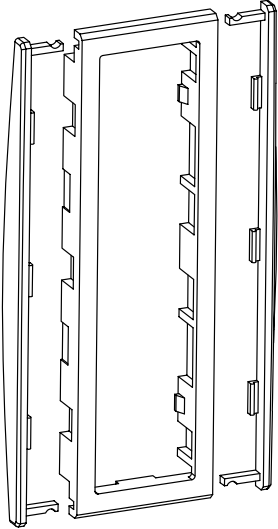
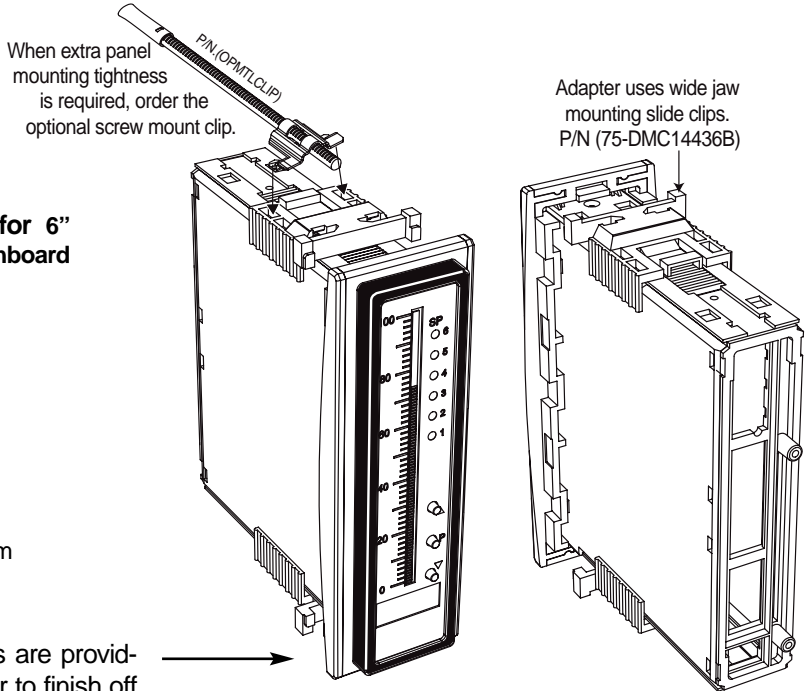

**Fits existing cut-outs for 6" (150 mm) edgewise switchboard pointer meters from:**

- Crompton
- G.E.
- Westinghouse
- Yokogawa
- and most others

Width: 43.7 mm to 48 mm (1.72" to 1.89")  
 Height: 143.4 mm to 149 mm (5.62" to 5.88")

Two bezel trim strips are provided with each adapter to finish off the edge of each individually mounted meter or the edge of each stack mounted array.

**Panel Adapter**  
 Part #: OP-PA/144X36

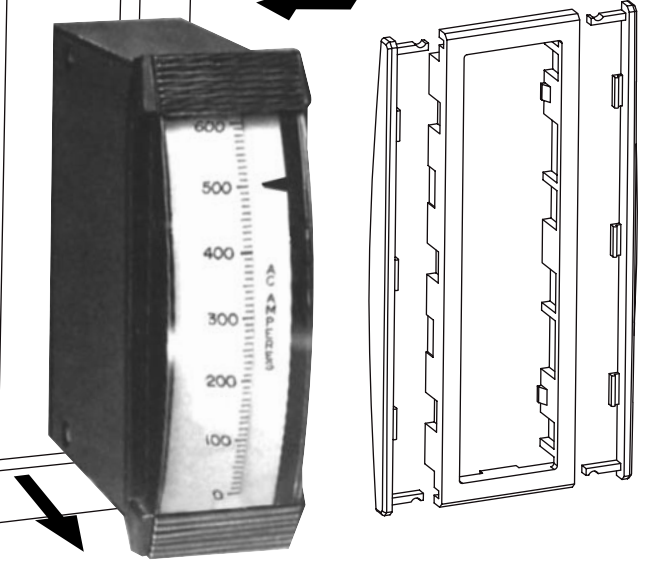
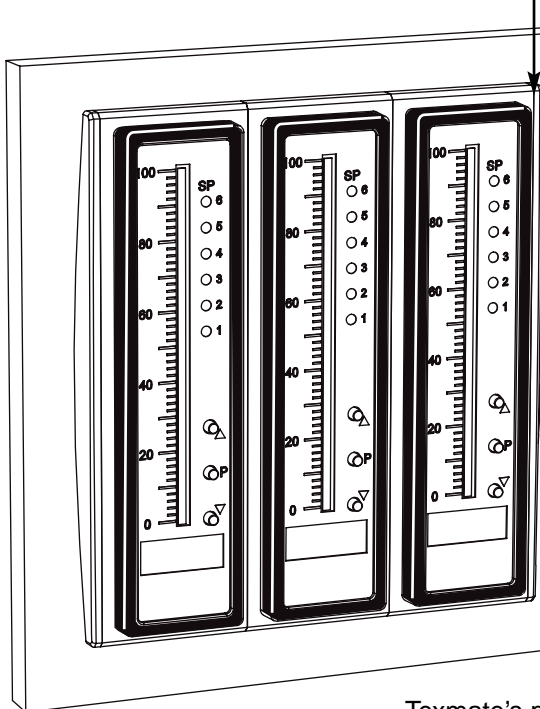

Texmate's panel adapter enables modern DIN meters to fit in existing cutouts individually or stacked when replacing old 6" edgewise mechanical pointer meters.

## Case Dimensions

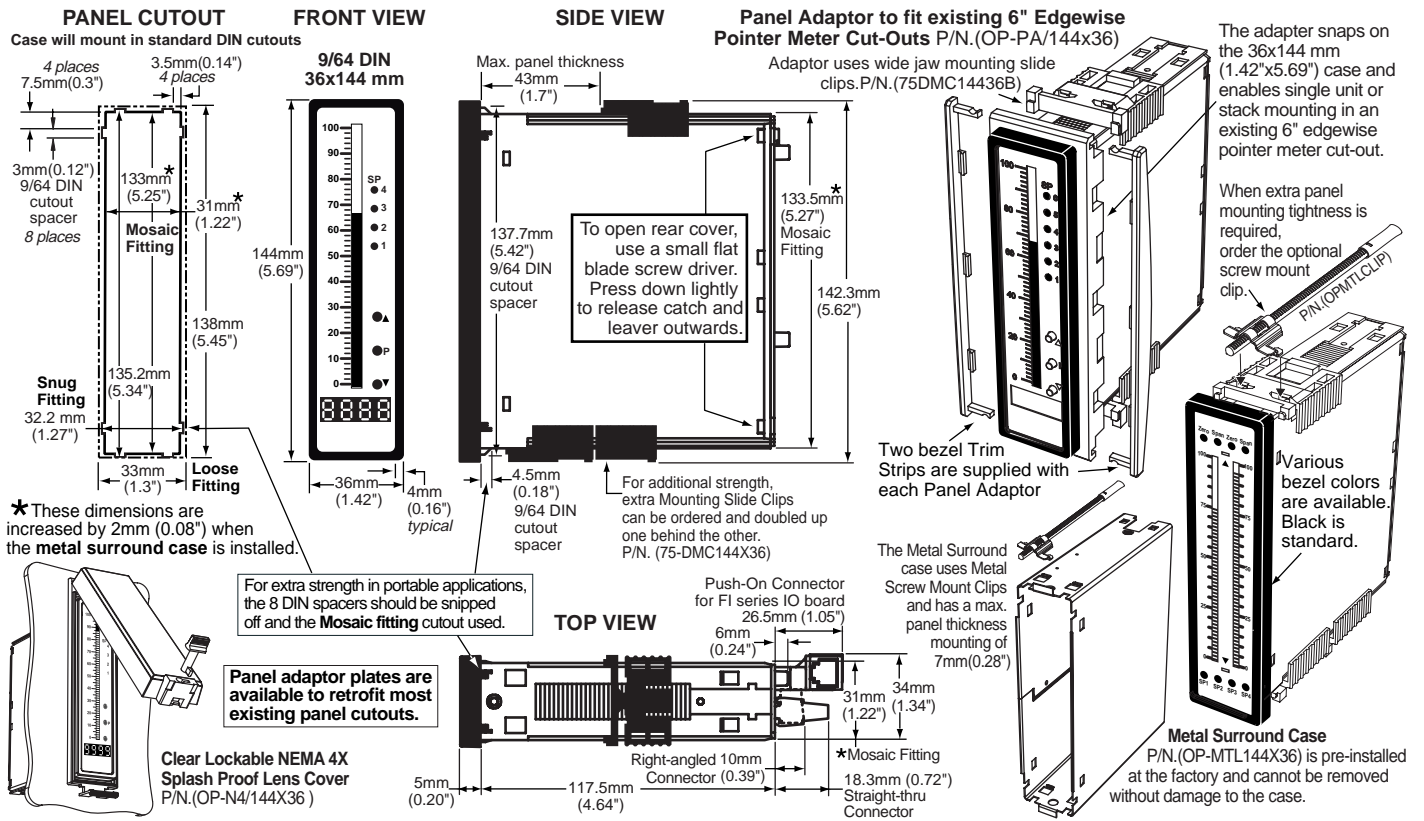

## Hinged Clear Lockable Polycarbonate NEMA 4X Splash Proof Cover

This rugged, impact resistant, clear lens cover is designed to be dust and water proof to NEMA 4 and IP65 standards. The lens cover consists of a base and cover with a cam hinge and key-lock locking device.

An O-ring, or neoprene gasket forms a seal between the base and the panel. When opened, a cam hinge prevents the cover from closing until pushed closed.

The cover has a tapered recess that, when closed, forms a capillary seal with a tapered ridge on the base. A capillary seal is created when capillary action causes a small amount of water to be drawn in between the two surfaces producing a water tight film around the sealing area.

For those applications, such as food processing, where fluid residues are unacceptable, apply a light coating of clear silicone grease, or other approved sealant to the mating groove to prevent any ingress of liquid and enable the cover to withstand steam cleaning.

Turning the key-lock tightens the cover to the base, ensuring seal integrity. A safety catch keeps the cover closed even when the key is turned to the open position and removed. The keyhole can also be used to attach a safety seal clip, preventing unauthorized opening.

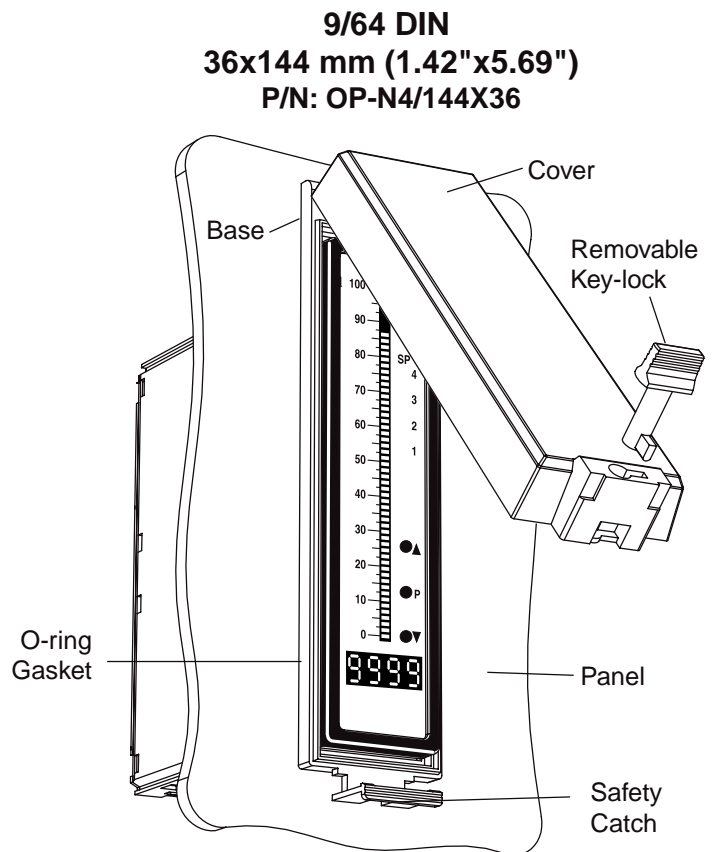

# Ordering Information



Add to the basic model number the order code suffix for each standard option required. The last suffix is to indicate how many different special options and or accessories that you may require to be included with this product.

**Ordering Example: FX-B101Q-VR-PS1-IA01-0A2, the 2 OA's are, CR-CHANGE and a OP-PA/144X36, \$145 + N/C + N/C + 35 + 7+ 8 = \$195**

### ► BASIC MODEL NUMBER

FX-B101Q . 144x36mm, Lynx, 101 Segment Bargraph . . . . . \$145

### Standard Options for this Model Number

Order Code Suffix	Description	List
<b>► DISPLAY</b>		
VR	. 101 Segment Red LED Bargraph, Vertical . . . . .	\$0
HR	. 101 Segment Red LED Bargraph, Horizontal . . . . .	\$5
VG	. 101 Segment Green LED Bargraph, Vertical . . . . .	\$15
HG	. 101 Segment Green LED Bargraph, Horizontal . . . . .	\$20

### ► POWER SUPPLY

PS1 . .85-265VAC/95-370VDC . . . . . N/C  
 PS2 . .15-48VAC/10-72VDC . . . . . \$35

### ► INPUT MODULES (Partial List. See www.texmate.com)

Unless otherwise specified Texmate will ship all modules pre calibrated with factory preselected ranges and/or scalings as shown in **BOLD** type.

IA01	. AC-Volts Scaled RMS, 200/ <b>600V AC</b> . . . . .	\$35
IA02	. AC-Volts Scaled RMS, 200mV/ <b>2V/20V AC</b> . . . . .	\$35
IA03	. AC-mA Scaled RMS, <b>2/20/200mA AC</b> . . . . .	\$40
IA04	. AC-Amps Scaled RMS, <b>0-1 Amp AC (0-100.00)</b> . . . . .	\$40
IA05	. AC-Amps Scaled RMS, <b>0-5 Amp AC (0-100.00)</b> . . . . .	\$40
IA06	. AC-Volts True RMS, 200/ <b>600V AC</b> . . . . .	\$55
IA07	. AC-Volts True RMS, 200mV/ <b>2V/20V AC</b> . . . . .	\$55
IA08	. AC-mA True RMS, <b>2/20/200mA AC</b> . . . . .	\$55
IA09	. AC-Amps True RMS, <b>0-1 Amp AC (0-100.00)</b> . . . . .	\$55
IA10	. AC-Millivolt, Scaled RMS, <b>100mV AC</b> . . . . .	\$55
IA11	. AC-Amps True RMS, <b>0-5 Amp AC (0-100.00)</b> . . . . .	\$55
IA12	. AC-Millivolt, True RMS, <b>100mV AC</b> . . . . .	\$55
ID01	. DC-Volts, <b>2/20/200V/Custom</b> w/24V DC Exc . . . . .	\$25
ID02	. DC-Millivolt, 20/50/ <b>100/200mV DC</b> w/24V DC Exc . . . . .	\$35
ID03	. DC-Milliamp, <b>2/20/200mA DC</b> w/24V DC Exc . . . . .	\$25
ID04	. DC-Amps, <b>5A DC</b> . . . . .	\$50
ID05	. DC-Volts <b>2/20/200/Custom V DC</b> w/Offset and 24V Exc . . . . .	\$45
ID07	. DC-Milliamp, <b>2/20/200mA DC</b> w/Offset and 24V Exc . . . . .	\$35
ID09	. DC-Amps, <b>1A DC</b> . . . . .	\$50
IF02	. Line Frequency, 50-500VAC, 199.9Hz, or optional 400Hz . . . . .	\$45
IGYZ*	. Universal Direct Pressure . . . . .	\$100
*View the IG- Ordering Code on page 11 to determine the value for Y & Z (IGAZ to IGKZ)		
IP01	. Process Loop, <b>4-20mA(0-100.00)</b> . . . . .	\$35
IP02	. Process Loop, <b>4-20mA(0-100.00)</b> w/24VDC Exc . . . . .	\$45
IP03	. Process Input, <b>1-5V DC(0-100.00)</b> w/Offset, 24V Exc . . . . .	\$45
IP07	. Universal Process <b>2V/5V/10V/20V/200V/2mA/20mA/Custom</b> . . . . .	\$30
IPT1	. Prototype Board for Custom Design . . . . .	\$15
IR02	. 3-Wire Potentiometer 1KΩ min (0-F.S.) . . . . .	\$40
IR03	. Linear Potentiometer, 3-wire, 1KΩ min . . . . .	\$40
IR04	. Resistance 2KΩ . . . . .	\$40

IS04	. Pressure Ext Exc., 20/2mV/V, 4/6-wire . . . . .	\$45
IS05	. Pressure/Load Cell 20/2mV/V, 5/10V Exc 4-wire . . . . .	\$55
IS06	. Pressure/Load Cell Ext Exc., 20/2mV/V, 4-wire . . . . .	\$55
IT03	. RTD, 100Ω Pt. 2/3/4-wire ( <b>-200 to 800°C</b> ) . . . . .	\$40
IT04	. RTD, 100Ω Pt. 2/3/4-wire ( <b>-200 to 1470°F</b> ) . . . . .	\$40
IT05	. RTD, 100Ω Pt. 2/3/4-wire ( <b>-190.0 to 199.0°F</b> ) . . . . .	\$40
IT06	. Thermocouple, J Type ( <b>0-1400 °F</b> ) . . . . .	\$40
IT07	. Thermocouple, K Type ( <b>0-1999°F</b> ) . . . . .	\$40
IT08	. Thermocouple, J Type ( <b>0-760 °C</b> ) . . . . .	\$40
IT09	. Thermocouple, K Type ( <b>0-1260°C</b> ) . . . . .	\$40
IT14	. RTD, 100Ω Pt. 2/3/4-wire ( <b>-199.0 to 199.0°C</b> ) . . . . .	\$40

### ► ANALOG OUTPUT

OIC . . Isolated 16 Bit Current Output, 4-20mA . . . . . \$35  
 OIV . . Isolated 16 Bit Voltage Output, 0-10VDC . . . . . \$35

### Special Options and Accessories (OA's)

Part Number	Description	List
-------------	-------------	------

#### ► SPECIAL OPTIONS (Specify Input & Req. Reading)

CR-CHANGE . . . . . Calibrated Range Change to another Standard Range . . \$7  
 CS-X/BAR . . . . . Custom Scaling within any Std. or Custom Selectable Range . . \$8  
 CSR-X/BAR . . . . . Custom Selectable Range Installation or Modification . . \$26  
 CSS-X/BAR . . . . . Custom Special Scaling beyond the Standard Range . . \$35  
 COA-X/SINGLE . . . . . Custom Output - Special Scaling of Analog Output . . \$15

#### ► ACCESSORIES (Specify Serial # for Custom Artwork Installation)

75-DMC144X36 . . Side Slide Brackets-Wide opening (2 pc) . . . . . \$2  
 75-DMC144X36 . . Side Slide Brackets-stand. (2 pc) - extra set . . . . . \$2  
 93-PLUG2P-DP . . Extra Screw Terminal Conn., 2 Pin Power Plug . . . . . \$2  
 93-PLUG2P-DR . . Extra Screw Terminal Conn., 2 Pin Plug . . . . . \$2  
 93-PLUG3P-DR . . Extra Screw Terminal Conn., 3 Pin Plug . . . . . \$3  
 93-PLUG4P-DR . . Extra Screw Terminal Conn., 4 Pin Plug . . . . . \$4  
 93-PLUG5P-DR . . Extra Screw Terminal Conn., 5 Pin Plug . . . . . \$5  
 DN.CAS144X36 . . Complete 144x36mm Case with bezel . . . . . \$20  
 OP-MTLCLIP . . . . . Screw Mounting Clips (2 pc) - to screw tighten slide brackets . \$6  
 OP-N4/144X36 . . 144x36mm clear lockable front cover-NEMA 4X, splash proof . . \$25  
 OP-PA/144X36 . . Panel Adapter for 144x36mm from 6 inch cutout . . . . . \$8  
 ART-FB-S/L . . . . . Custom Faceplate - Artwork & setup Library . . . . . \$35  
 ART-FB-S/L/C . . . . . Custom Faceplate - Artwork & setup Library + Logo . . . . . \$75  
 ART-FB-S/N . . . . . Custom Faceplate - Artwork & setup Non-library . . . . . \$55  
 ART-FB-S/N/C . . . . . Custom Faceplate - Artwork & setup Non-library + Logo . . . . . \$95  
 ART-FB-001 . . . . . Install Custom Faceplate per meter - 1 color . . . . . \$10  
 ART-FB-002 . . . . . Install Custom Faceplate per meter - 2 color . . . . . \$20  
 ART-FB-003 . . . . . Install Custom Faceplate per meter - 3 color . . . . . \$30

Many other options and accessories are available. See full price list for more details.

Prices subject to change without notice.

### WARRANTY

Texmate warrants that its products are free from defects in material and workmanship under normal use and service for a period of one year from date of shipment. Texmate's obligations under this warranty are limited to replacement or repair, at its option, at its factory, of any of the products which shall, within the applicable period after shipment, be returned to Texmate's facility, transportation charges pre-paid, and which are, after examination, disclosed to the satisfaction of Texmate to be thus defective. The warranty shall not apply to any equipment which shall have been repaired or altered, except by Texmate, or which shall have been subjected to misuse, negligence, or accident. In no case shall Texmate's liability exceed the original purchase price. The aforementioned provisions do not extend the original warranty period of any product which has been either repaired or replaced by Texmate.

### USER'S RESPONSIBILITY

We are pleased to offer suggestions on the use of our various products either by way of printed matter or through direct contact with our sales/application engineering staff. However, since we have no control over the use of our products once they are shipped, NO WARRANTY WHETHER OF MERCHANTABILITY, FITNESS FOR PURPOSE, OR OTHERWISE is made beyond the repair, replacement, or refund of purchase price at the sole discretion of Texmate. Users shall determine the suitability of the product for the intended application before using, and the users assume all risk and liability whatsoever in connection therewith, regardless of any of our suggestions or statements as to application or construction. In no event shall Texmate's liability, in law or otherwise, be in excess of the purchase price of the product.

Texmate cannot assume responsibility for any circuitry described. No circuit patent or software licenses are implied. Texmate reserves the right to change circuitry, operating software, specifications, and prices without notice at any time.



995 Park Center Drive • Vista, CA 92081-8397

Tel: 1-760-598-9899 • USA 1-800-839-6283 • That's 1-800-TEXMATE

Fax: 1-760-598-9828 • Email: sales@texmate.com • Web: www.texmate.com

Texmate has facilities in Japan, New Zealand, Taiwan, and Thailand. We also have authorized distributors throughout the USA and in 28 other countries.

For product details visit [www.texmate.com](http://www.texmate.com)

Local Distributor Address