

Associated Documents

The following documents must be read together with this supplement:

Relevant Tiger 320 Series User's Manual

The user's manual provides general information on the relevant Tiger 320 Series meter.

Tiger 320 Series Programming Code Sheet (NZ101)

The programming code sheet provides all meter programming codes including set-point programming codes.

Registers Supplement (NZ209)

This supplement provides a detailed description of ASCII and Modbus registers. All available ASCII and Modbus registers are listed in tables.

Configuration Utility Program Tutorial (NZ206)

This supplement provides instructions on using the Texmate developed Meter Configuration Utility program.

Tiger Development System Tutorial (NZ212)

This supplement provides details on Texmate's library of factory installed macros written specifically for our customers unique applications. The tutorial describes the method of writing a macro for simple to complex applications, in varying levels of complexity.



Programming Tip

This document has been written using a DI-50 7-segment, 5-digit display meter. When programming meters with other display options, some display readings may vary to the diagrams shown.



Programming Tip

It is assumed that you are familiar with the Programming Conventions used throughout the range of Texmate Tiger 320 Series literature as described in the user's manual.

This document is designed to supplement the information on the Serial Communications Output Module described in the Tiger 320 Series User's Manual.

Contents

Technical Specifications	3
Technical Description	3
Serial Communications Hardware Pinouts & Interconnections	15
Meter Functions using Serial Communications	17
Meter Programming Codes	28
Serial Output Configuration Programming Codes	29
Component Layout	32
Set Up & Programming Procedures	33

List of Figures

<i>Figure 1 – Serial Communications Output Overview</i>	3
<i>Figure 2 – Character Frame Formats</i>	5
<i>Figure 3 – Timing Diagram</i>	7
<i>Figure 4 – Example of a Command String</i>	9
<i>Figure 5 – Examples of Multiple Write Command</i>	9
<i>Figure 6 – RS-232 Hardware Connections</i>	15
<i>Figure 7 – RS-485 Hardware Connections</i>	15
<i>Figure 8 – RJ-11 Connections</i>	16
<i>Figure 9 – RJ-11 to 9-pin and 25-pin D Connectors</i>	16
<i>Figure 10 – Programming via Serial Port</i>	17
<i>Figure 11 – Logging and Printing</i>	18
<i>Figure 12 – Retrieving Logged Data</i>	21
<i>Figure 13 – Meter Modes for Communication using Print Mode</i>	22
<i>Figure 14 – Printing Data</i>	23
<i>Figure 15 – Combining Two Isolated Inputs</i>	25
<i>Figure 16 – Controlling a Process with Two Meters</i>	25
<i>Figure 17 – Providing a Second Display</i>	26
<i>Figure 18 – Computer to Meter Control Mode Example</i>	26
<i>Figure 19 – Programming Code List</i>	28
<i>Figure 20 – Exploded View of Meter Modular Boards</i>	32
<i>Figure 21 – Meter to Meter Connection through Serial Ports</i>	37
<i>Figure 22 – Computer to Meter Control Mode Example</i>	38
<i>Figure 23 – Example Graph in Microsoft Excel</i>	47



WARNING Symbol

The WARNING symbol is generic to all Tiger 320 Series documents and indicates that if the instruction is not heeded, the action may result in loss of life or serious injury.



NOTE Symbol

The NOTE symbol is generic to all Tiger 320 Series User's Manual supplements and indicates important or helpful information on the topic being discussed.



PROGRAMMING TIP Symbol

The programming tip symbol is generic to all Tiger 320 Series documents and indicates useful tips when programming the instrument.

Definitions

The following definitions are relevant to the Tiger 320 Series serial output module:

X

If an X appears in the description of a 3-digit programming code or in a configuration procedure, this means that any number displayed in that digit is not relevant to the function being explained, or more than one choice can be made.

Meter – Controller

The term meter, as used throughout this document, is a generic term for all Tiger 320 Series signal processors and controllers.

TDS – Tiger Development System

To further enhance the control and automation functionality of the Tiger 320's operating system, a compiler program, known as the Tiger Development System (TDS), allows Texmate or our customer to customize the controller with a standard or unique macro for almost any OEM application.

- Standard Serial Output Module:** Isolated RS-232 or isolated RS-485 serial interface using a simple, Texmate developed, isolated ASCII communication protocol (uses standard ASCII character set) or ModBus communication protocol.
- Data:** 8-bit.
- Parity:** None, Odd, Even.
- Baud Rate:** 300, 600, 1200, 2400, 4800, 9600, 19200 Kb/s.
- Bus Address:** 1 to 255.
- Multi-device Connection:** Up to 64 devices connected in parallel or series using RS-485 serial interface.
- DeviceNet Module:** For further information on a DeviceNet compatible communication interface, see DeviceNet Supplement (NZ215).
- Ethernet Module:** For further information on an Ethernet compatible communication interface, see Ethernet Supplement (NZ216).

Technical Description

The standard serial communications output module is one of three serial output options available with Tiger 320 Series meters.

An RS-232 or RS-485 serial interface board is mounted directly on the meter's output carrier board during factory installation. Both RS-232 and RS-485 communicate with an external device using the ASCII or ModBus mode.

Only one serial interface board, either RS-232 or RS-485, can be mounted in the meter at any time.

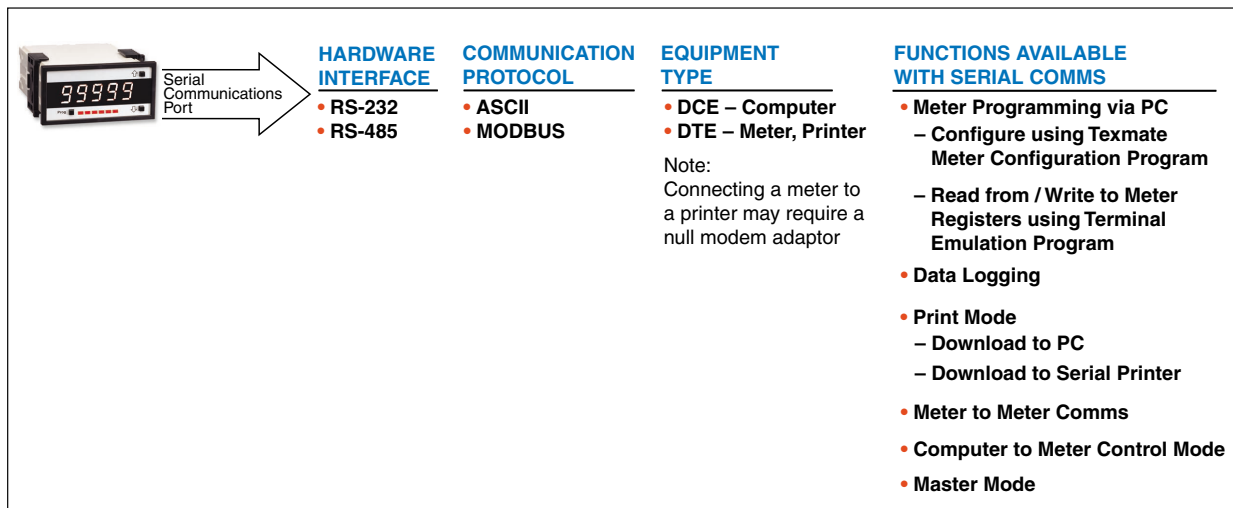

Figure 1 – Serial Communications Output Overview

Interface Standards

There are three serial interface standards commonly found in use today: RS-232, RS-422, and RS-485. The three interfaces are Electrical Industry Association (EIA) standards that define the 25-pin interconnection of Data Terminal Equipment (DTE) and Data Communication Equipment (DCE). The interface standards use serial binary interchange between two devices to communicate with each other.

A DTE transmits data on the transmitted data (TXD) line and receives data on the received data (RXD) line. Conversely, a DCE receives data on the TXD line and transmits data on the RXD line.

Depending on the application, Tiger 320 Series meters are normally connected using either RS-232 or RS-485.

RS-232 Serial Communication Interface

The RS-232 interface supports transmission lengths of up to 15 meters (50 feet), although this distance is pushed further in practice.

RS-422 Serial Communication Interface

The distance limitation of RS-232 is overcome with the RS-422 interface. RS-422 supports transmission lengths of up to 1000 meters (3600 feet). Both RS-232 and RS-422 support connection between only two devices on the bus at one time. RS-422 uses a 4-wire design consisting of:

- Transmit+.
- Transmit-.
- Receive+.
- Receive -.



Note:

Tiger 320 Series meters do not use the RS-422 interface.

RS-485 Serial Communication Interface

The RS-485 interface supports similar transmission distances to RS-422, as well as multi-drop operation where up to 64 devices may be connected at one time. RS-485 uses a 2-wire system with a plus and minus signal line to transmit and receive data. Therefore, RS-485 is always half-duplex because it cannot transmit and receive data simultaneously. When a device needs to send data, it connects its transmitter to the signal lines, and when it needs to receive data, it connects its receiver to the signal lines.

If more than one receiving device is connected to the interface, a unique node address must be assigned to each device. The node address must preface each command. If only one device is connected, the node address specifying command may be ignored.

The node address is set in the Calibration Mode.



See Serial Communications Hardware Pinouts & Interconnections on Page 15 for information on RS-232 and RS-485 connection details.

See Serial Communications Interface Setup Procedure on Page 39.

Communication Formats

ASCII Mode

The ASCII mode is a simple, Texmate developed, isolated ASCII communication protocol using the standard ASCII character set. This mode provides external communication between the meter and a PC allowing remote programming to be carried out.

Tiger 320 Series meters use a serial communication channel to transfer data from the meter to another device. With serial communications, data is sent one bit at a time over a single communications line. The voltage is switched between a high and a low level at a predetermined transmission speed (baud rate) using ASCII encoding. Each ASCII character is transmitted individually as a byte of information (eight bits) with a variable idle period between characters. The idle period is the time between the receiving device receiving the stop bit of the last byte sent and the start bit of the next byte. The receiving device (for example a PC) reads the voltage levels at the same interval and then translates the switched levels back to an ASCII character. The voltage levels depend on the interface standard being used.

Table 1 lists the voltage level conventions used for RS-232 and RS-485. The voltage levels listed are at the receiver.

See Table 2 for a list of the most commonly accessed ASCII mode registers.

Table 1 Interface Voltage Level Conventions			
Logic	Interface State	RS-232	RS-485
1	Mark (idle)	TXD, RXD: -3 to -15 V	a+b < -200 mV
0	Space (active)	TXD, RXD: +3 to +15 V	a-b > +200 mV

Each ASCII character is 'framed' with:

- A start bit.
- An optional error detection parity bit.
- And one or more ending stop bits.

For communication to take place, the data format and baud rate (transmission speed) must match that of the other equipment in the communication circuit. Figure 2 shows the character frame formats used by the meter.

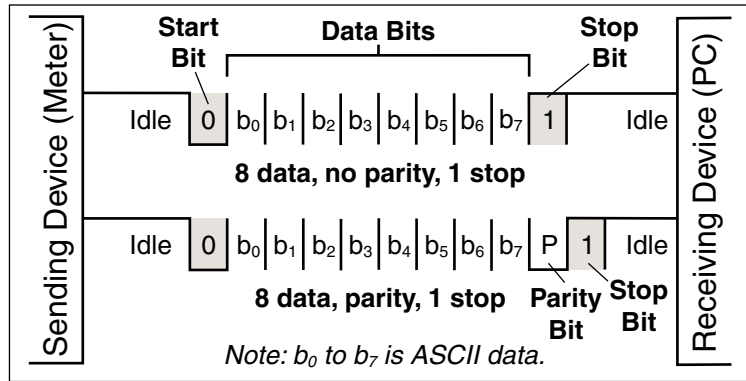

Figure 2 – Character Frame Formats

Modbus Mode

The Modbus mode uses the Modbus communication protocol to provide external communication between a controller (Tiger 320 Series meter) and a process device for monitoring, control, and automation purposes.

Tiger 320 Series meters use Modbus RTU (Remote Terminal Unit) communication. This is an 8-bit binary transmission mode. In the Modbus mode the controller acts as a slave to a Modbus master (PC or PLC). Data transfers are based on registers and can only be initiated by the Modbus master. Table 2 lists the most commonly accessed Modbus mode registers, which contain 32-bit fixed point data.

The Modbus master must be configured to accept this type of data. Once this is done, seamless communication between the Modbus master and Modbus slave can be initiated.

The main advantage of this mode is that its greater character density allows better data throughput than ASCII for the same baud rate. Each message must be transmitted in a continuous stream.

See Table 2 for a list of the most commonly accessed Modbus mode registers.



Note:

It is beyond the scope of this supplement to describe the Modbus communication format protocol.

For detailed information on ASCII and Modbus mode registers, see Registers Supplement (NZ209).

Table 2 Common ASCII and Modbus Registers (32-bit Registers)		
ASCII Reg. N#	Function	Modbus Reg. N#
1	Alarm Status	40000
2	Display Register	40513
3	Processed Data Result	40515
4	Processed Data – Channel 1	40517
5	Processed Data – Channel 2	40519
39	Processed Data – Channel 3	40521
40	Processed Data – Channel 4	40523
6	Setpoint 1	40535
7	Setpoint 2	40537
8	Setpoint 3	40539
9	Setpoint 4	40541
10	Setpoint 5	40543
11	Setpoint 6	40545
12	Peak	40525
13	Valley	40527
14	Tare	40533
15	<i>Reserved for Texmate Use</i>	–
16	Total 1	40529
17	Total 2	40531

Character Frame Formats

Start Bit and Data Bits

Data transmission always begins with the start bit. The start bit signals the receiving device to prepare to receive data. One bit period later, the least significant bit of the ASCII encoded character is transmitted, followed by the remaining data bits. The receiving device then reads each bit position as they are transmitted and, since the sending and receiving devices operate at the same transmission speed (baud rate), the data is read without timing errors.

Parity Bit

To prevent errors in communication, the sum of data bits in each character (byte) must be the same: either an odd amount or an even amount. The parity bit is used to maintain this similarity for all characters throughout the transmission.

It is necessary for the parity protocol of the sending and receiving devices to be set before transmission. There are three options for the parity bit, it can be set to either:

- None – which means there is no parity.
- Odd – which means the sum of bits in each byte is odd.
- Even – which means the sum of bits in each byte is even.

After the start and data bits of the byte have been sent, the parity bit is sent. The transmitter sets the parity bit to 1 or 0 making the sum of the bits of the first character odd or even, depending on the parity protocol set for the sending and receiving devices.

As each subsequent character in the transmission is sent, the transmitter sets the parity bit to a 1 or a 0 so that the protocol of each character is the same as the first character: odd or even.

The parity bit is used by the receiver to detect errors that may occur to an odd number of bits in the transmission. However, a single parity bit cannot detect errors that may occur to an even number of bits. Given this limitation, the parity bit is often ignored by the receiving device. The user sets the parity bit of incoming data and sets the parity bit to odd, even or none (mark parity) for outgoing data.

The parity bit is set in the Calibration Mode.

Stop Bit

The stop bit is the last character to be transmitted. The stop bit provides a single bit period pause to allow the receiver to prepare to re-synchronize to the start of a new transmission (start bit of next byte). The receiver then continuously looks for the occurrence of the start bit.



Note:
Tiger 320 Series meters use only one stop bit.

Command Response Time

The meter uses half-duplex operation to send and receive data. This means that it can only send or receive data at any given time. It cannot do both simultaneously. The meter ignores commands while transmitting data, using RXD as a busy signal.

When the meter receives commands and data, after the first command string has been received, timing restrictions are imposed on subsequent commands. This allows enough time for the meter to process the command and prepare for the next command.

See Figure 3. At the start of the time interval t_1 , the sending device (PC) prints or writes the string to the com port, thus initiating a transmission. During t_1 the command characters are under transmission and at the end of this period the command terminating character is received by the meter. The time duration of time interval t_1 is dependent on the number of characters and baud rate of the channel:

$$t_1 = (10 * \# \text{ of characters}) / \text{baud rate}$$

At the start of time interval t_2 , the meter starts to interpret the command, and when complete performs the command function.

After receiving a valid command string, the meter always indicates to the sending device when it is ready to accept a new command. After a read command, the meter responds with the requested data followed by a carriage return ($\text{\textcircled{D}}\text{H}$) and a line feed ($\text{\textcircled{A}}\text{H}$) character. After receiving a write command, the meter executes the write command and then responds with a carriage return/line feed.

The sending device should wait for the carriage return/line feed characters before sending the next command to the meter.

If the meter is to reply with data, time interval t_2 is controlled by using the command terminating character: \$ or *. The \$ terminating character results in a response time window of 50 ms minimum and 100 ms maximum. This allows enough time to release the sending driver on the RS-485 bus. Terminating the command line with the * symbol, results in a response time window (t_2) of 2 ms minimum and 50 ms maximum. The faster response time of this terminating character requires that sending drivers release within 2 ms after the terminating character is received.

At the start of time interval t_3 , the meter responds with the first character of the reply. As with t_1 , the time duration of t_3 is dependent on the number of characters and baud rate of the channel:

$$t_3 = (10 * \# \text{ of characters}) / \text{baud rate}$$

At the end of t_3 the meter is ready to receive the next command.

The maximum throughput of the meter is limited to the sum of the times: t_1 , t_2 , t_3 .



Note:
The command response time delay for the Modbus format is set in the Calibration Mode. See Serial Communications Settings Configuration Procedures on Page 33.

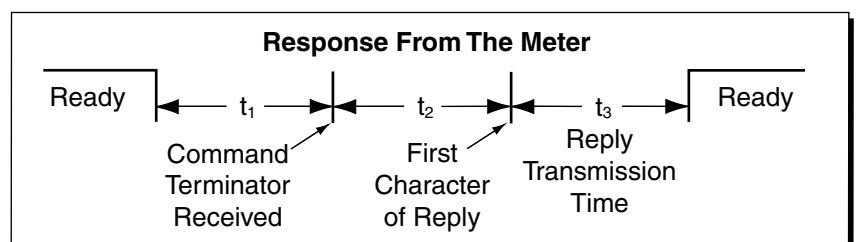

Figure 3 – Timing Diagram

ASCII Serial Mode Read/Write Information

ASCII Command Character Descriptions

Table 3 describes the functions of the command string characters. Table 4 shows examples of how the command string is constructed.

Table 3 Command Character Descriptions		
Command	Description	Function
S or s	Start Character	The start character must be the first character in the string.
0 to 255	Meter (Node) Address Specifier	The next character assigns an address to a specific meter. If the character following the start character is not an ASCII number, then address 0 is assumed. All meters respond to address 0.
R or r for read W or w for write	Read/Write Command	The next character is the read/write command character. The read command reads a register from the meter. The write command writes to a register of the meter. Using any other character for the read or write character will abort the operation
ASCII number 1 to 65535	Register Address	The register address for the read/write operation is specified next. It can either be an ASCII number from 1 to 65535 or register 1 to 18 can be accessed by entering an ASCII letter from A to R (not case sensitive). If the address character is omitted in a read command, the meter will always respond with the data value currently on the display. The register address must be specified for a write command.
Space or ,"	Separator Character	After the register address in a write command, the next character must be something other than an ASCII number. This is used to separate the register address from the data value. It can be a space or a , or any other character except a "\$" or a "*" .
Range between -9999999 to 9999999	Data Value	After the separator character, the data value is sent. It must be an ASCII number in the range of -9999999 to 9999999 (Fixed Point Register). Note: The range will vary depending on which register is accessed.
\$ or *	Message Terminator	The last character in the message is the message terminator . This must be either \$ or * . If the \$ is used as a terminator, a minimum delay of 50 ms is inserted before a reply is sent. If the * is used as a terminator, a minimum delay of 2 ms is inserted before a reply is sent. The \$ and * characters must not appear anywhere else in the message string.
CR/LF	Meter Response	After the meter has completed a read or write instruction, it responds by sending a carriage return/ line feed back to the host. If the instruction was a read command, the CR/LF follows the last character in the ASCII string. If it was a write command, the CR/LF is the only response sent back to the host. The host must wait for this before sending any further commands to the meter. A read or write to a not valid or non-existent register, produces a null character followed by a CR/LF.

Table 4 ASCII Command String Examples	
Command String	Command String Description
SR\$	Read display value, 50 ms delay, all meters respond.
s15r\$	Read display value, 50 ms delay, meter address 15 responds.
SR12*	Read peak value, 2 ms delay, all meters respond.
Sr130*	Read Code 1 setting, 2 ms delay, all meters respond.
s2w2 -10000\$	Write 10 000 to the display register of meter address 2, 50 ms delay.
SWT Chan_1\$	Write ASCII text string Chan_1 to text register T, 50 ms.
S10w148,7*	Change brightness to 7 on meter address 10, 2 ms delay.

Command String Construction

When sending commands to the meter using a Terminal emulation program, a string containing at least one command character must be constructed. A command string consists of the following characters and must be constructed in the order shown:

- 1) A start character.
- 2) The meter (node) address (optional).
- 3) The read/write command.
- 4) The register address.
- 5) A separator character.
- 6) The data value.
- 7) The message terminator.

Figure 4 shows an example of a command string.

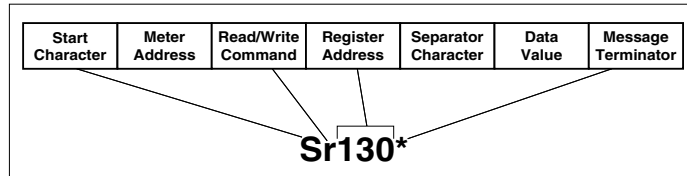

Figure 4 – Example of a Command String

Multiple Write

The multiple write feature of the Tiger meter allows multiple registers to be written to in a single ASCII command string. It is similar to a normal write command but with the following differences:

- After the first data value, a separator character is inserted instead of the message terminator. The next register address is then specified, followed by another separator character and the next data value. This procedure is repeated for each new register. The message terminator is added after the last data value in the string.
- Any number of registers can be written to using the multiple write feature, as long as the total length of the command string does not exceed 73 ASCII characters, including spaces and the message terminator.

Figure 5 shows two examples of the multiple write command.



Note:

The multiple write feature cannot be used with special ASCII registers (H to X).

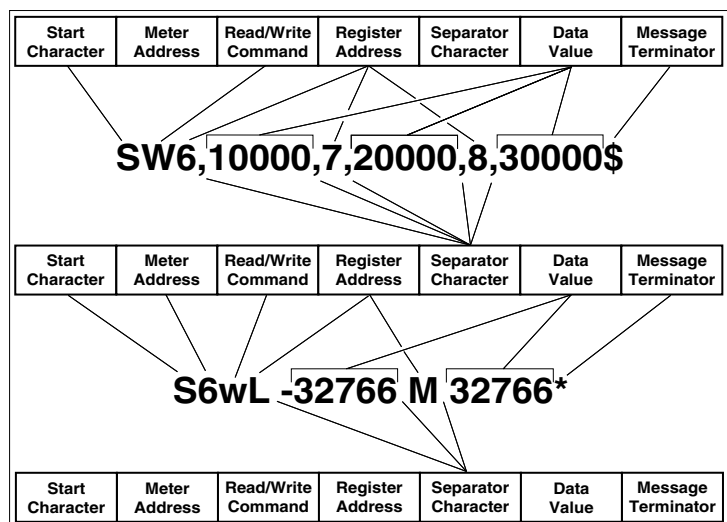

Figure 5 – Examples of Multiple Write Command

Special ASCII Registers

Tiger 320 Series meters can have either 5-digit or 6-digit displays using either 7-segment or 15-segment display LEDs. Table 5 shows which characters can be used with a 7-segment display LED along with the associated ASCII value. Table 6 shows which characters can be used with a 15-segment display LED along with the associated ASCII value.

7-Segment ASCII Characters

Some characters, such as Kk, Mm, Qq, Ww, Zz, can not be displayed correctly on a 7-segment LED display (Note this does not apply to characters on 15-segment displays). For these characters the closest possible display has been chosen. The letters M and W can only be represented by using two digits of the display. This means that each time an M or W is used, the maximum amount of characters to be displayed is reduced by one (e.g. Power would be displayed as Powr). If both letters are used, for example in the abbreviation MW for megawatt, the amount of characters to be displayed is reduced by two. Upper or lower case letters are accepted by the meter but the resulting display is set to the standard 7-segment character map. See Table 5.

Table 5 ASCII Characters for 7-Segment Display			
Character	Register Control value (Decimal)	Character	Register Control value (Decimal)
Space	32	@	64
!	33	A	65
"	34	b	66
#	35 (not supported)	C	67
\$	36 (not supported)	d	68
%	37 (not supported)	E	69
&	38 (not supported)	F	70
'	39	G	71
(40	H	72
)	41	i	73
*	42 (not supported)	J	74
+	43 (not supported)	k	75
,	44 (displayed as decimal point)	L	76
-	45	M	77 (supported, but requires two digits)
.	46	n	78
/	47	o	79
0	48	P	80
1	49	q	81 (not supported)
2	50	r	82
3	51	S	83
4	52	t	84
5	53	u	85
6	54	V	86
7	55	W	87 (supported, but requires two digits)
8	56	X	88
9	57	Y	89
:	58 (displayed as decimal point)	Z	90 (same as "2")
;	59 (displayed as decimal point)	[91 (same as "C")
<	60	\	92
=	61]	93
>	62	^	94
?	63	_	95

Table 6 ASCII Characters for 15-Segment Display			
Character	Register Control value (Decimal)	Character	Register Control value (Decimal)
Space	32	@	64
!	33	A	65
"	34	b	66
#	35	C	67
\$	36	d	68
%	37	E	69
&	38	F	70
'	39	G	71
(40	H	72
)	41	i	73
*	42	J	74
+	43	k	75
,	44	L	76
-	45	M	77
.	46	n	78
/	47	o	79
0	48	P	80
1	49	q	81
2	50	r	82
3	51	S	83
4	52	t	84
5	53	u	85
6	54	V	86
7	55	W	87
8	56	X	88
9	57	Y	89
:	58 (displayed as decimal point)	Z	90
;	59	[91 (same as "C")
<	60	\	92
=	61]	93
>	62	^	94
?	63	_	95

Registers H to W – Display Customizing

Text can be customized on the following text displays to suit a particular application:

- Register H – Text display for peak.
- Register I – Text display for valley.
- Register J – Text display for total.
- Register K – Text display for sub-total.
- Register L – Text display for setpoint 1.
- Register M – Text display for setpoint 2.
- Register N – Text display for setpoint 3.
- Register O – Text display for setpoint 4.
- Register P – Text display for setpoint 5.

- Register Q – Text display for setpoint 6.
- Register R – Text display for overrange.
- Register S – Text display for underrange.
- Register T – Text display for channel 1.
- Register U – Text display for channel 2.
- Register V – Text display for channel 3.
- Register W – Text display for channel 4.

For 5-digit meters the text string displayed by the meter can be 5 ASCII characters long. For 6-digit meters the text string displayed by the meter can be 6 ASCII characters long.

If a text string is read in the usual manner. For example, **SRT\$**, where:

- **S** for the start character.
- **R** for the read character.
- **T** for the text display for Channel 1.
- **\$** for the message terminator.

The meter responds by displaying the stored string: **CH_1**.

To customize the text string of the text display for Channel 1, from **CH_1** to **Hello**, issue the following command:

SWT Hello\$

When the text display for Channel 1 is displayed on the meter, instead of **CH_1** being displayed, **Hello** is now displayed.

Register X – Print String

The print mode allows the meter to print data from any meter register directly to a serial printer, or to a PC where it can be imported into a spreadsheet.

Register X is a special register that allows you to specify the text and data stored in specific registers to be printed out when a print command is issued by the meter while in the print mode. Through the serial port, register X can be either written to or read from using a terminal program on a PC.

Writing To Register X

Writing to register X tells the meter to print the data stored in one or more of the meter's registers when the print command is issued. To get the meter to print, the printer must be connected to the meter through the serial port and the meter must be programmed to [XX3] in Code 3. The data to be printed depends on how the meter has been programmed, for example, to display a flow rate and total.

The total length of a write string can be up to 30 ASCII characters long

See Printing Restrictions on Page 13.

Reading From Register X

Reading from register X allows you to check your settings prior to removing the PC from the serial port and connecting to a printer. Register X can be read in the normal manner (i.e. SRX\$).

Example of Writing To Register X

The following example shows a write to register X with the meter set to display flow rate and total flow of channel 1 in Code 2.

swx Rate = ~2 (add carriage return and line feed)

Total = ~16\$

The above write to register X means the following:

swx: Start writing to register X.

Rate =: Tells the meter to print the word Rate =.

~2: Tells the meter to print the current flow rate (display data), held in register 2, after the word Rate =.

Total =: Tells the meter to print the word Total =.

~16: Tells the meter to print the current total flow (stored data), held in register 16, after the word Flow =.

The printer would then print, for example, the following:

Rate = 2000
Total = 25000

This means that the current flow rate is 2000 and the total flow at this point is 25000.

Example of Reading From Register X

Having written the above example to the meter, to check the contents of register X using the terminal program through the PC, type the following:

srx\$

The following is shown on the PC screen:

Rate = ~2
Total = ~16\$

Printing Restrictions

When printing, any alphanumeric ASCII character can be used within the following restrictions:

- The \$ and * characters are reserved for the terminating character at the end of the string and cannot be used as part of the text string.
- The total string length must be no greater than 30 bytes long. This includes spaces, tabs, carriage returns, line feeds, and the terminating character. There must be a separator space between the register address X and the start of the string. This separator space does not have to be included in text string length calculations.
- Any number following a ~ character will be interpreted as a register address. During a print-out the register's current value will be printed out in this position.
- The ASCII character \ is treated as a special character in the print string. When a \ is encountered, a * is printed in its place (* is reserved as a terminating character and normally can not appear anywhere in the text string). This allows the print output of one meter to be connected to another meter that is operating in the ASCII mode.

See Meter to Meter Communication on Page 24.

For example, if the print string reads:

swx sw3 ~5\ sw4 ~12\ sw6 ~2\ \$

The printer prints the following:

sw3 (current register value)* **sw4** (current register value)*
sw6 (current register value)*



Note:

As a new line is usually represented by a carriage return and a line feed, two bytes should be added for each new line in text string length calculations.

Up to seven different registers can be specified in one text string, provided that the total string length is no greater than 30 bytes long and the total length of the resulting printout is less than 100 bytes long (including time stamp if selected).

For example, the following tab delimited output could be specified to input display data, processed result, processed channel 1, processed channel 2, peak, valley, and total, directly into a spreadsheet:

swx ~2(tab)~3(tab)~4(tab)~5(tab)~12(tab)~13(tab)~p\$

When calculating the length of the printout, an allowance of 7 bytes for each register address should be used, plus any extra text or separating characters such as tabs or spaces.

Serial Output Module Settings

Setting the 1st digit to 2 and the 2nd digit to 0 [CAL] [20X] accesses the serial communications output module properties: baud rate, parity, transmit time delay, and address settings.

Baud Rate

The baud rate range is selectable from 600 to 38400 baud. The default baud rate is 9600.

- 600.
- 1200.
- 2400.
- 4800.
- 9600.
- 19200.
- 38400.

Parity

The default parity setting is [oFF]. Parity [odd] or [EVEN] can also be selected.

Transmit Time Delay

The transmit time delay restricts the meter from transmitting a reply to a slow or busy master device (PC, PLC, etc.) by providing time delays of 2, 20, 50, or 100 milliseconds for all serial modes except ASCII (Code 3 set to XX0).

The ASCII Mode uses message terminating characters:

- * = 2 milliseconds.
- \$ = 50 milliseconds.

Address

For RS-485 serial communications the default address setting is 1, but can be set to anywhere between 1 and 255.

RS-232 Interconnections

Hardware Requirements

The following hardware is required to set the meter up for simple RS-232 communications (see Figure 6):

- Tiger 320 Series meter with RS-232 serial output module option installed.
- RJ-11 to DB-25 interface connector (and possibly a DB-25 to DB-9 interface connector depending on PC serial port).
- Standard 4-wire cable with male RJ-11 connectors (see Figure 8 and 9, and Tables 7 and 8 for a wiring diagram and pin descriptions).
- PC running a terminal program.

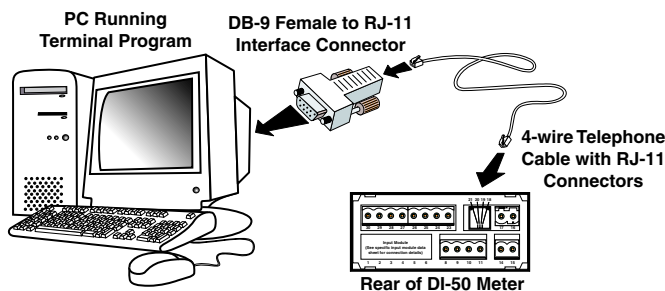

Figure 6 shows a simple RS-232 connection between a Tiger 320 Series meter and a PC.

This setup could be used for remote programming of the meter using the Texmate Meter Configuration Program.

Figure 6 – RS-232 Hardware Connections

RS-485 Interconnections

Hardware Requirements

The following hardware is required to set the meter up for simple RS-485 communications (see Figure 7):

- A number of Tiger 320 Series meters with an RS-485 serial output module option installed (this can be up to 64 meters).
- A number of RJ-11 dual outlet adapters to connect the meters in series (amount depends on the number of meters installed).
- RJ-11 to DB-25 interface connector.
- Texmate isolated converter (RS-485 to RS-232)
- Possibly a DB-25 to DB-9 interface connector depending on PC serial port.
- Lengths of standard 2-wire telephone cable with male RJ-11 connectors (enough to connect the meters in series and connect to the RJ-11 to DB-25 interface connector). See Figure 9 and Table 8 for a wiring diagram and pin descriptions.
- PC running a terminal program.

Figure 7 shows a number of Tiger 320 Series meters with the hardware required to connect directly to a PC using RS-485. This setup could be used for remote programming of each meter using the Texmate Meter Configuration Program from a single PC.

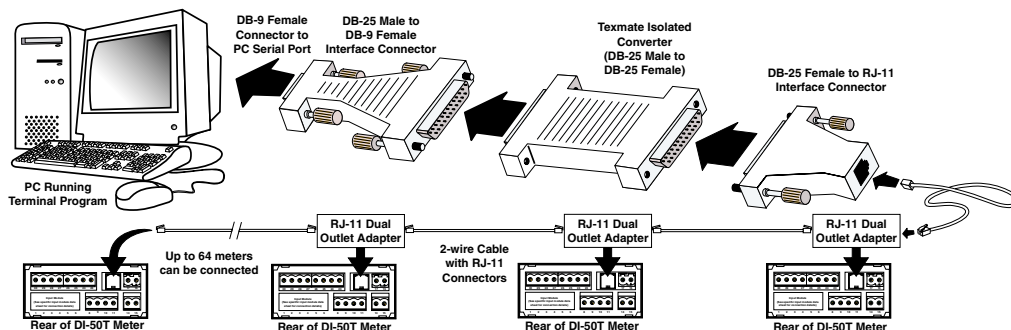

Figure 7 – RS-485 Hardware Connections



Note:

In theory, up to 64 meters can be connected together. The meters can be connected together in series or parallel using RJ-11 type connectors or hardwiring (each meter can only be hardwired if it has a screw terminal instead of an RJ-11 connector). Figure 7 has the meters connected in series using RJ-11 type connectors.

Table 7 lists the pinouts for an RS-232 or RS-485 to RJ-11 socket configuration for Terminal 5 on Tiger 320 Series DI and GI meter case configurations and Terminal 6 on FI meter configurations.

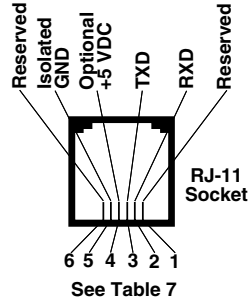
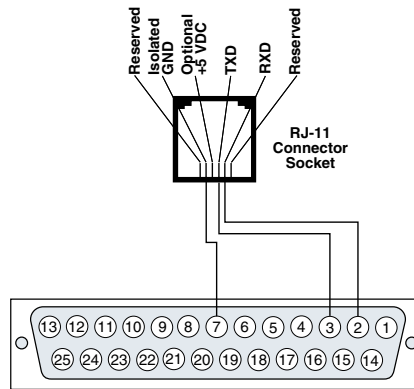

Figure 8 – RJ-11 Connections

Table 7 Serial Communication Pinouts (RJ-11 Socket)		
TERMINAL PINS	RS-232	RS-485
1	Reserved for future use	Reserved for future use
2	RXD. Received Serial	B (Low)
3	TXD. Transmitted Serial	A (High)
4	Optional +5 VDC to power external converters (jumper on RS-232 or RS-485 boards must be soldered)	Optional +5 VDC to power external converters (jumper on RS-232 or RS-485 boards must be soldered)
5	Isolated Ground	Isolated Ground
6	Reserved for future use	Reserved for future use

Table 8 lists the pinouts for an RS-232 to 9-pin or 25-pin D connector.



25-Pin D Connector
(See Table 8 for pin descriptions)
(Viewed from the pin side of a female connector)

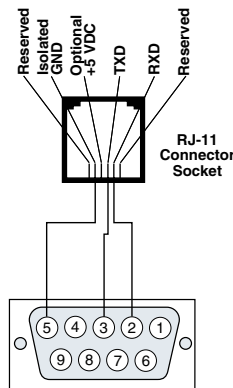

9-Pin D Connector
(See Table 8 for pin descriptions)
(Viewed from the pin side of a female connector)

Figure 9 – RJ-11 to 9-pin and 25-pin D Connectors

Table 8 RS-232 to 25-Pin & 9-Pin D Connectors		
25-Pin	Pin Name	9-Pin
1	Frame Ground	-
2	Receive Data	3
3	Transmit Data	2
4	Request to Send	7
5	Clear to Send	8
6	Data Set Ready	6
7	Signal Ground	5
8	Data Carrier Detect	1
9	Reserved	-
10	Reserved	-
11	Unassigned	-
12	Sec. Carrier Detect	-
13	Sec. Carrier Send	-
14	Sec. Transmit Data	-
15	Transmitter Clock	-
16	Sec. Receive Data	-
17	Receiver Clock	-
18	Local Loopback	-
19	Sec. Request to Send	-
20	Data Terminal Ready	4
21	Remote Loopback/Signal Quality Detect	-
22	Ring Indicator	9
23	Data Rate Select	-
24	Transmitter Clock	-
25	Test Mode	-

With a standard serial output module installed, the meter can be configured for various data transfer and data capture functions:

- Programming the meter via a PC using a Texmate developed interface program or a terminal emulation program. *See Meter Programming via Serial Port.*
- Data logging of up to 4000 data samples. *See Data Logging.*
- Printing data directly to a serial printer for archiving or downloading data to a PC for further processing. *See Data Printing via Print Mode.*
- Meter to meter communication to combine two isolated inputs, to control a process, or to provide a second display. *See Meter to Meter Communication.*
- Providing manual control over the meter's inputs and outputs through the computer to meter control mode. *See Computer to Meter Control Mode.*
- Control over macro functionality using the master mode. *See Master Mode on Page 27.*

Meter Programming via Serial Port

With a serial output module installed, the meter can be fully configured using a PC and either:

- The Meter Configuration Utility Program.
- Or a terminal emulation program such as HyperTerminal.

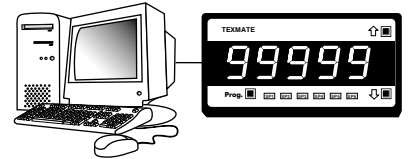

Figure 10 – Programming via Serial Port

Meter Configuration Utility Program

The **meter configuration utility program** is a Texmate developed, intuitive, user oriented Windows based interface between the PC and the meter. In addition to all application function settings, the configuration program also provides access to the following additional features.

Code Blanking

Code blanking is used to blank out any codes not used by an application. This makes them operator tamper-proof, but leaves selected codes open for operator adjustment.

Display Text Editing

Display text editing allows you to edit the display text of a number of display windows to suit the specifics of your application. For example, a setpoint could be edited to read [TNK_Lo] for tank level low, or [brKoF] for brake off.

Configuration Data Copying

This function allows the current meter configuration settings to be copied and saved for later referral or for restoration.

Macros

Texmate has a growing library of macros to suit a wide range of standard customer applications. Macros can be installed in the meter, via the macro compiler, known as the Texmate Development System (TDS), or the configuration utility program and run automatically when the meter is powered up.



The Meter Configuration Utility Program programming software is available with the purchase of a standard serial output module.

For further information, see the Meter Utility Configuration Program Supplement (NZ212).

Terminal Emulation Program

A terminal emulation program, such as HyperTerminal, provides another interface between a PC and the meter. The terminal program allows you to read from or write to any register in the meter using an ASCII character command string.

Macro Compiler Program

In addition to our library of factory installed macros, customers can write and run their own unique set of powerful macros to suit their individual OEM applications.

Texmate's Tiger Development System (TDS) allows customers to write, compile, and download their own macros. These macros can be easily written in BASIC to utilize any combination of the hundreds of functions embedded into the Tiger 320 Operating System.

This enables customers to use a standard meter for a number of unique applications by simply writing and downloading their application specific macro.

Data Logging

Data logging function settings are configured in Code 8.

More than 4000 samples (data records) can be stored (logged) in non-volatile memory for before and after analysis of any process condition. Up to 512 kilobits (64 kilobytes) of on-board memory is available for continuous loop recording.

Data logging can be triggered (activated) from a set-point, the program button, or from an external switch. With a real-time clock installed, date and time stamps can be included.

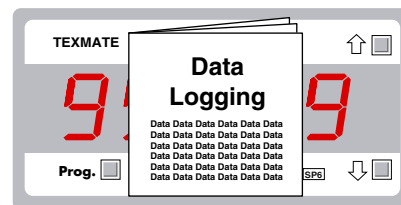

Figure 11 – Logging and Printing

Data Logging Concepts

The data logging function uses the concept of pointers to control where a sample is to be written to and where one is to be read from. These pointers are referred to as the log write pointer and the log read pointer.

Register 720 – Log Write Pointer

Register 720 is a 16-bit register that points to the most recent log sample written by the meter. It counts up from 0 each time a new sample is logged, with the maximum number of samples being limited by the size of non-volatile memory installed in the meter. Before a new sample is written, the meter first checks to make sure that it is not overwriting a sample that has not been read. It does this by comparing the write pointer with the read pointer. If they are the same, data logging is halted until a read is actioned. If this occurs, new samples are lost. When the sample number reaches the maximum count it either wraps around to zero or stops logging, depending on what type of buffer has been selected in Code 8: Cyclic or Linear.

Register 720 can be read from or written to. Make sure that any values written to this pointer are within the allowable range for the size of the installed memory.

Register 721 – Log Read Pointer

Register 721 is a 16-bit register that points to the most recent log sample read from the meter. It counts up from 0 each time log data is read from the meter, with the maximum number of samples being limited by the size of non-volatile memory installed in the meter. When it reaches the maximum count it either wraps around to zero or stops logging, depending on what type of buffer has been selected in Code 8: Cyclic or Linear.

Register 721 can be read from or written to. Make sure that any values written to this pointer are within the allowable range for the size of the installed memory.

Buffer Types

The 1st digit of Code 8 **activates** the data logging feature by selecting a data log buffer type. The meter has two types of buffer.

Cyclic Buffer

Setting Code 8 to 1XX selects the **cyclic** buffer. In this mode the log write pointer (register 720) increments each time a sample is taken until the number of samples exceed the maximum sample number – determined by the amount of non-volatile memory installed.

When the cyclic buffer is full, the logged data is replaced on a first on first off basis. This means that when the buffer is full, the first logged sample is discarded to make way for a new sample at the end of the logged data string. It then wraps around to sample number 1 again.

*See description **Register 720 – Log Read Pointer** for information about not overwriting old samples that have not been read.*

Linear Buffer

Setting Code 8 to 2XX selects the **linear** buffer. In this mode the log write pointer is incremented each time a sample is taken until the sample number reaches the maximum sample number – determined by the amount of non-volatile memory installed. When the linear buffer is full the meter stops logging data. The buffer must be reset to 0.

See **Reset Buffer**.

Reset Buffer

If Code 8 is set to 3XX the **log write** and **log read** pointers are reset to zero when the PROGRAM button is pressed. Code 8 then reverts back to the same setting it had before the reset function was executed. Note that when the reset function is executed, the contents of the buffer is not destroyed, only the pointers are changed.

Register 723 to 726

Registers 723 to 726 are used to specify which registers are to be logged. Register 723 specifies the first register to be logged, 724 the second, 725 the third, and 726 the fourth. The exact number of registers logged by the data logger depends on the setting of Code 8 and the size of the registers being logged.

If a full time stamp (i.e. date & time) is selected, registers 723 and 724 both point to 32-bit registers, then only the two registers specified by 723 and 724 are logged. If no date or time stamp is selected then more registers can be logged. If a value of zero is written to one of the registers specified by 723 and 724, the log sample is terminated from that register onwards. This can be used for applications that only require one register to be logged.

Registers 723 to 726 can be read from and written to as normal registers. Only register numbers 1 to 256 can be used by the data logger, so registers 723 to 726 must contain a value within this range. Any value over 256 produces incorrect results. Registers 723 to 726 can only be configured via the serial port and are not accessible from the front panel buttons.

Non-volatile Memory Options

Up to 512 kilobits of non-volatile on-board memory (EEPROM) can be installed. The number of samples logged depends on the size of the installed memory:

- 32 kilobits (1 x 32 kb EEPROM):176 samples.
- 512 kilobits (2 x 256 kb EEPROM):4016 samples.

Each sample is stored in 15 bytes of memory:

- 1 byte required for trigger source.
- 3 bytes required for date stamp if used.
- 3 bytes required for time stamp if used.

The number of registers logged depends on the size of the registers:

- 8-bit registers use:2 bytes (1 reference, 1 data).
- 16-bit registers use:3 bytes (1 reference, 2 data).
- 32-bit registers use:4 bytes (1 reference, 3 data).

Note, data is only stored as a 24-bit number not a 32-bit number.

For example:

- 4 x 8-bit registers plus date and time stamp use 15 bytes.
- 3 x 16-bit registers plus time stamp use 13 bytes.
- 2 x 32-bit registers plus date and time stamp use 15 bytes.
- 3 x 32-bit registers use 13 bytes.

Data Output Format

The second digit of Code 8 configures the data logging and print mode result data with a time stamp format.

Time Stamp Options

Four different time stamp options are available:

- Time stamp format 0:No time stamp.
- Time stamp format 1:[Month-Date-Year, Hours:Minutes:Seconds].
- Time stamp format 2:[Date-Month-Year, Hours:Minutes:Seconds].
- Time stamp format 3:[Hours:Minutes:Seconds].

Printer/Spreadsheet Format

Code 8 also allows the time stamp format the selection of a print or spreadsheet style output. The print style output is designed for printers with a narrow roll of paper. Parameters are printed down the page with each parameter on a new line using a carriage return and line feed. The spreadsheet style output is designed for inputting data directly into a computer. Each sample is printed on a single line with a tab delimiter placed between parameters.

The number of channels that can be logged depends on the use of time stamps and the amount of non-volatile memory installed:

- Log up to 4 channels:No time stamp.
- Log up to 3 channels:Plus time stamp format 3: Hours:Minutes:Seconds.
- Log up to 2 channels:Plus time stamp format 1: Month-Date-Year. Hrs:Mins:Secs.
- Log up to 2 channels:Plus time stamp format 2: Date-Month-Year. Hrs:Mins:Secs.



Note:

Printer style date and time stamps have a carriage return and line feed. Spreadsheet style time and date stamps are continuous on a single line. All date and time stamps are generated from the optional real-time clock.

On Demand Log or Print Data Triggers

The 3rd digit of Code 8 provides a feature for logging or printing on demand using one of the following rear pins or pushbuttons as a trigger source:

- PROGRAM button.
- F1 button (DI-60A5C or DI-802X6C meters only).
- F2 button (DI-60A5C or DI-802X6C meters only).
- HOLD pin (external switch connected to the HOLD and COMMON pin).
- LOCK pin (external switch connected to the LOCK and COMMON pin).

Retrieving Logged Data

Once data has been logged, it can be retrieved using the ASCII Mode or PRINT Mode via a serial port command.

The ASCII Mode provides greater control of the logged data to be retrieved by reading the logged data from register 722 and register 727. The log write pointer (register 720) and the log read pointer (register 721) can also be modified in the ASCII Mode and the most recent logged data sample in either pointer can be read using a terminal program. See Figure 12.

Table 9 shows the methods available for retrieving logged data.

Table 9 Retrieving Logged Data	
Retrieve Data	Modify Log Pointers
ASCII Mode (Code 3 – XX0)	
Register 722 Read from register 722 to download a single sample of logged data.	Log Read Pointer (register 720) <i>See Data Logging on Page 18.</i>
Register 727 Read from register 727 to download the whole buffer of logged data.	Log Write Pointer (register 721) <i>See Data Logging on Page 18.</i>
PRINT Mode (Code 3 – XX3)	
L – Log Print The meter responds to sending an upper or lower case ASCII character L to the meter, by printing the next sample of logged data, pointed to by the data log read pointer (register 721). <i>See Print Mode Commands on Page 24.</i>	! – Clear Log Data The meter responds to sending an ASCII character ! to the meter, by clearing both the log write pointer (register 720) and the log read pointer (register 721). <i>See Print Mode Commands on Page 234</i>

Retrieving Data

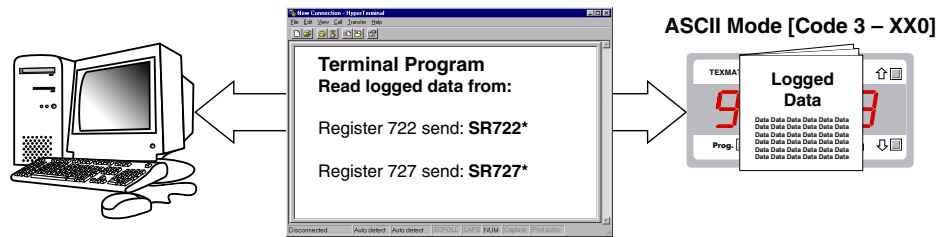

Modifying Log Pointers

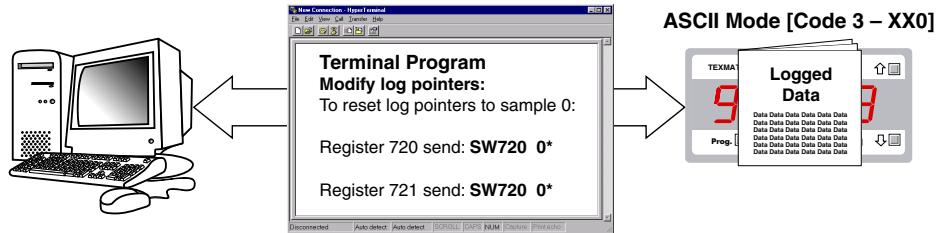

Log Print

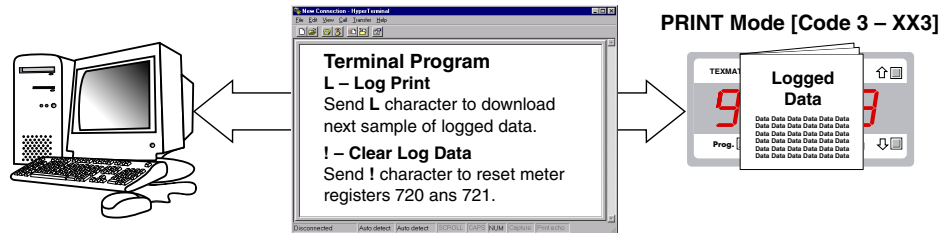

Figure 12 – Retrieving Logged Data

Register 722 – Read Log Data at Log Read Pointer

Register 722 is used to read the next sample of log data. It does this by comparing the **log read pointer** (register 721) with the **log write pointer** (register 720). If they are equal then there has been no new samples logged since the last read and the message **No New Log Data** is sent as a response. If they are not equal, the log read pointer (register 721) is incremented to point to the new sample, and the new log data is transmitted. Registers 720 and 721 can be used to control the data logger. To reset the data logger, both registers 720 and 721 should be set to 0 (or any other value in the allowable range of memory).

A write to register 722 causes a new log sample to be taken. The value written to the register is ignored and registers 723 to 726 are logged as normal. This allows a log sample to be taken on demand via the serial port or from the control of the macro. Data logging (either cyclic or linear) must be enabled in Code 8 for this feature to function.

Register 727 – Read Log Data at Log Read Pointer

Register 727 is a read only register similar to register 722, except that it is used to read multiple log samples with a single command. A read of register 727 outputs log data starting at the sample pointed to by the read pointer, and continues to output log samples up to the latest sample pointed to by the write pointer. Each time it outputs a log sample the read pointer is automatically incremented. At the end of the sequence the read pointer is equal to the write pointer. This command can also be used to read a selected block of log samples by modifying the read pointer (register 721) and the write pointer (register 720) prior to reading register 727.

Data Error!

When a log sample is stored, a checksum is also stored to verify that the data is correct when it is read. If the contents of a sample becomes corrupted, or if the read pointer is set to an address that does not contain a valid sample, the following text is printed:

Log # (sample no.)

Data Error!

Error 1

If the checksum of a sample is correct but the register number that has been logged is not a valid register number, the following text is printed:

Log # (sample no.)

Trig:SP1

Reg #0=Error 1



See Example Application Procedures – Data Logging, for a set of data logging procedures.
See Data Printing via Print Mode for further information on the PRINT Mode function.

Data Printing via Print Mode

The PRINT Mode is a simple method of accessing data results stored in the meter. The PRINT mode is primarily designed for applications that require a paper printout of data results printed directly to a serial printer. A powerful print string can be programmed to send descriptive text of 31 characters and data directly to a serial printer or PC. See Figures 13 and 14.

Data results can be printed at regular time intervals in response to a button press on the meter, or when a setpoint is activated. When any of these pre-selected events occurs, the meter transmits a user defined ASCII string of data from its serial port. The contents of the text string can contain date and time stamp information and can also include current register data for any register in the meter. The print string can be customized by setting the meter into the ASCII mode and writing to register X.

See Register X – Print String on Page 12 for more details.

Table 10 shows the methods available for printing data.

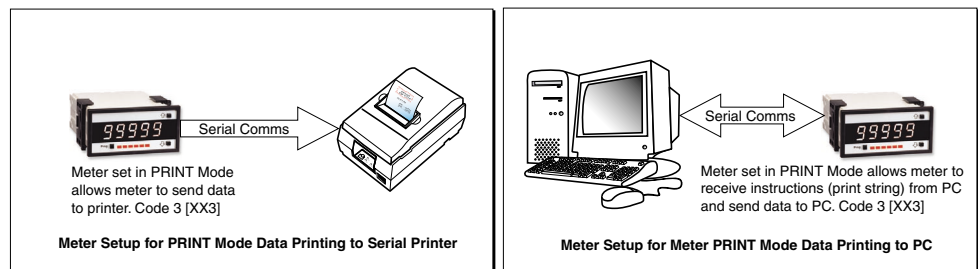
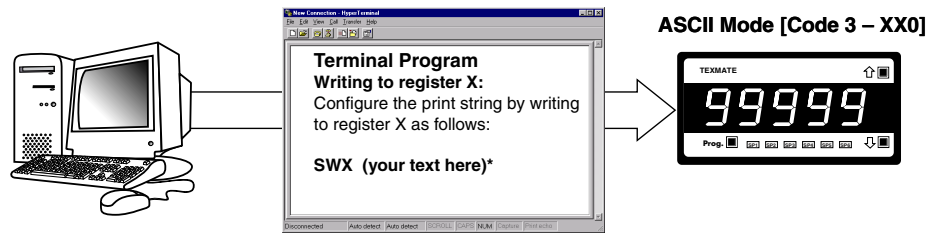

Figure 13 – Meter Modes for Communication using Print Mode

Table 10		Printing Data	
ASCII Mode (Code 3 – XX0)		PRINT Mode (Code 3 – XX3)	
<p>Configure Print String: With the meter set up in the ASCII Mode and using a terminal program, configure the print string by writing to register X.</p> <p><i>See Register X – Print String on Page 12.</i></p>		<p>Automatic Print Trigger: A register or setpoint is defined as the print trigger and automatically activates the meter to print selected data to the serial port.</p> <p><i>See Data Printing via Print Mode on Page 22.</i></p>	
		<p>PRINT Mode Command: Send one of the following commands to meter via a terminal program:</p> <p>P – Demand Print: Prints user defined print string.</p> <p><i>See Print Mode Commands on Page 24.</i></p>	
		<p>Automatic ON DEMAND Trigger: Pushbutton or switch activates the meter to print selected data to the serial port.</p> <p><i>See On Demand Log or Print Data Triggers on Page 20.</i></p>	

Configure Print String



Automatic Print Trigger

PRINT Mode [Code 3 – XX3]

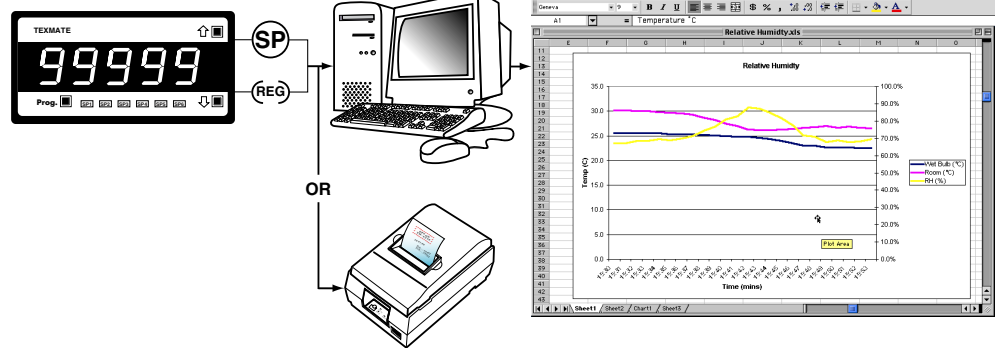

PRINT Mode Commands

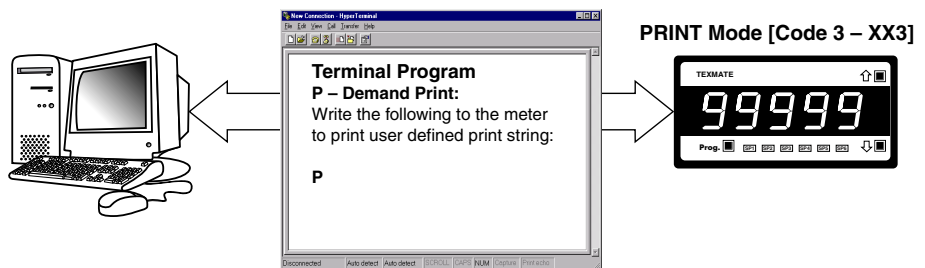

Automatic ON DEMAND Trigger

PRINT Mode [Code 3 – XX3]

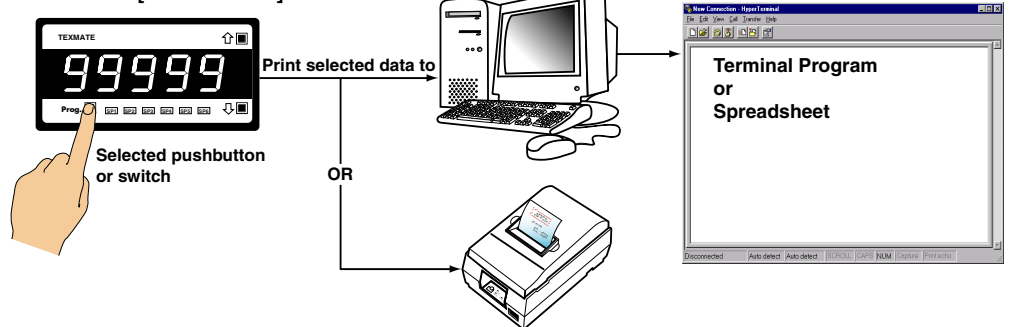

Figure 14 – Printing Data

Data Printing Direct to Serial Printer

Data can be printed directly from the meter to a serial printer using the meter's serial communications port. A total print string length of 30 bytes can be printed.

Note:

May require a Null Modem Adaptor. See your printer manual for further information.

Data Printing Direct to PC

The print mode can also be used to print data to a PC where it is captured in a Windows terminal program. The data can be printed with or without a Day: Month: Year date stamp or Hours: Minutes: Seconds time stamp.

Print Mode Commands

When the meter is set up in the print mode it normally sends data without any prompting from any other device based on the trigger conditions configured in the meter. However, in some cases the meter may be required to print on demand by another device such as another Tiger 320 Series meter or a PC. To accommodate this there are several commands that the meter responds to when set in the print mode.

P – Demand Print

If the meter is set up in the print mode and it receives an upper or lower case ASCII character **P**, it responds by printing the user defined print string in the same way that it would do from any other trigger condition.

L – Log Print

If the meter is set in print mode and it receives an upper or lower case ASCII character **L**, it responds by printing the next sample of logged data, pointed to by the data log read pointer (register 721). It then increments the data log read pointer to the next location to be read in preparation for the next read. If a log print is requested but there is no new sample data to be read, the meter responds with the text: **End Of Log Data**.

! – Clear Log Data

If the meter is set up in the print mode and it receives an ASCII character **!**, it resets both the data log read and write pointers to zero and responds with the text: **Clear Log Data**.



Note:

The ! character does not actually delete any logged sample data. It merely resets the log read & write pointers back to the beginning of the buffer. If the ! character is unintentionally sent, then provided no new data is logged, the old data can be retrieved by resetting the log write pointer back to it's original position.

Esc – Force ASCII Mode

If the meter is set up in the print mode and it receives an ASCII escape character 27 (0x1B hex), the meter is forced out of the print mode and into the ASCII communications mode (Code 3 XX0). This allows the Texmate Meter Configuration Program to access and configure a meter that is set in print mode.



Example – See Data Printing via the PRINT Mode on Page 35 for an example set of step-by-step procedures to configure the meter for Data Printing activated by the PRINT Mode.

Meter to Meter Communication

All Tiger 320 Series meters are capable of meter to meter communication by connection through the serial port and downloading data in an ASCII format. This allows for data and resource sharing. Two Tiger meters are connected together allowing data to be transferred from the master meter (sender) to the slave meter (receiver).

The master meter is programmed to operate in the print mode, while the slave meter is programmed to operate in the ASCII mode. The print mode allows the master meter to send data in an ASCII format through the serial port to the slave meter. The slave meter's ASCII mode then writes the data to the meter's pre-programmed registers. The print and ASCII modes are configured in Code 3.

Meter to meter communication has a number of useful applications, such as:

- Combining two isolated inputs for further processing and display (see Figure 15).
- Combining two meters to control a process (see Figure 16).
- Providing an accurate second display of the master meter's data at a remote location (see Figure 17).

Combining Two Isolated Inputs

Although all Tiger 320 Series meters can have up to four analog input signals, the signals are not isolated from each other. For some applications this can be a problem. To process two isolated inputs requires two separate meters. By connecting two Tiger meters through the serial port the processed result data of each isolated signal can be combined and further processed in one of the meters.

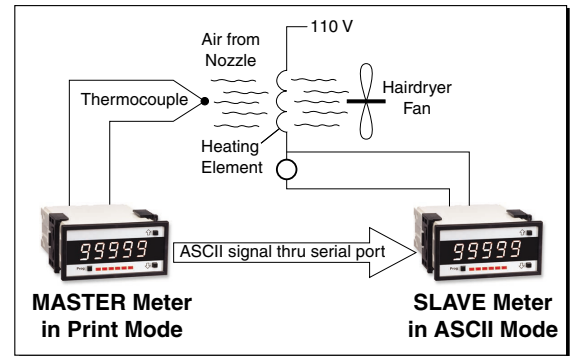

Figure 15 – Combining Two Isolated Inputs

For example, a Tiger 320 Series meter is used to measure the current in the heating element of a hair dryer. A second Tiger meter is used to measure the temperature of the air in the nozzle when the fan and heater are operating. This is to see if the air in the nozzle responds in a predictable manner during the different stages of the hair dryer operation. In practice the tip of the thermocouple sometimes shorts on the heating element. This is why the input signal from each sensor must be isolated (see Figure 15).

The meters are configured as master and slave with the master set up in the print mode [XX3] and the slave meter set up in the ASCII mode [XX0] in Code 3. This means that when the master receives an input signal the data is processed by the meter and the result converted to ASCII format. Through the print mode, the ASCII format data is sent to the slave where it is received and combined with the result of the slave meter's own processed input signal. Both signals are further processed by the slave and the result displayed on the meter.

Combining Two Meters to Control a Process

It is also possible to combine two Tiger 320 Series meters through the serial port to increase the control over a process application.

For example, a Tiger meter is used to control the temperature of the liquid in a tank. Another Tiger meter is used to monitor the flow of the liquid leaving the tank.

It was found that the flow rate was not measured as accurately as was desired. This was due mainly to the temperature variation of the liquid.

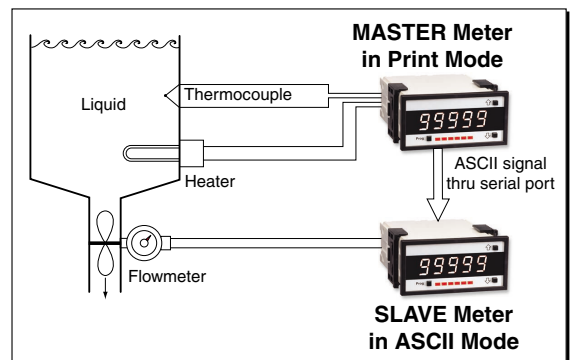

Figure 16 – Controlling a Process with Two Meters

To overcome this the two Tiger meters were connected through their serial ports and the temperature data sent to the flow rate meter (slave). The temperature data meter (master) converts the data to ASCII format. The flow rate meter then uses the temperature and the flow rate data to compensate for the differences in the liquid temperature. This improves the accuracy of the system to the desired level (see Figure 16).

The temperature data meter is the master meter and is configured in the Print Mode in Code 3 [XX3]. This means that instead of sending the data in ASCII format to a printer, it is sent to the flow rate meter. The flow rate meter is the slave meter and is set up in the ASCII Mode in Code 3 [XX0]. This means that it can receive the ASCII formatted data sent from the master meter (temperature data meter) and use it to compensate out any differences in the liquid temperature and provide improved flow rate accuracy.

Providing an Accurate Second Display

Most intelligent meters use an analog output to send a digital data signal from one meter to another meter. This method can result in a slight loss of accuracy due to the drift in the analog circuit. To maintain the accuracy of the digital data signal while sending between two Tiger meters, the signal is converted to ASCII format and sent through the serial port.

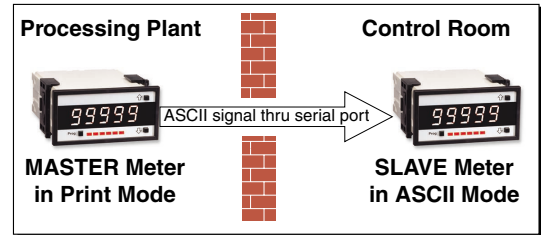

Figure 17 – Providing a Second Display

Two Tiger meters can be connected through their serial ports. The data, converted to ASCII format, is transferred directly from the master (sending) meter to the slave (receiving) meter with no loss in accuracy. The master meter is configured in the Print Mode in Code 3 [XX3]. This means that instead of sending the data in ASCII format to a printer, it is sent to the slave meter. The slave meter is configured in the ASCII Mode in Code 3 [XX0]. This means that it can receive the ASCII formatted data sent from the master meter and translate this into an instruction to display the data (see Figure 17).



See Example – Providing an Accurate Second Display on Page 37 for a set of detailed step-by-step configuration procedures.

Computer to Meter Control Mode

The computer to meter control mode suspends the meter's automatic control over its inputs and outputs. Through the meter's serial port, ASCII mode serial communications provides manual control of the inputs and outputs by writing to and reading from the meter's registers using a PC running a test program.

Example – Heater Testing Station

For example, in order to gather statistical information for further analysis, a manufacturer of heating elements wants to test each element to make sure they conform to the specifications. This is done by setting the element up in a test jig and checking the resistance of the elements at one operating point on the heater. The test jig is connected to a meter, which in turn is connected to a PC. Each test jig and meter is a single test station. See Figure 18.

To speed up the testing process, the user can connect up to 64 testing stations (meter and test jig) to one host PC using RS-485 communications. Each testing station is given a unique ID number so that it can be individually addressed.

For simplicity, we have described the testing process of only one testing station. Figure 18 shows the set up of the testing station and the read/write processes between the PC and the meter.



See Computer to Meter Control Mode Configuration Procedures on Page 38 for a set of step-by-step procedures for this example

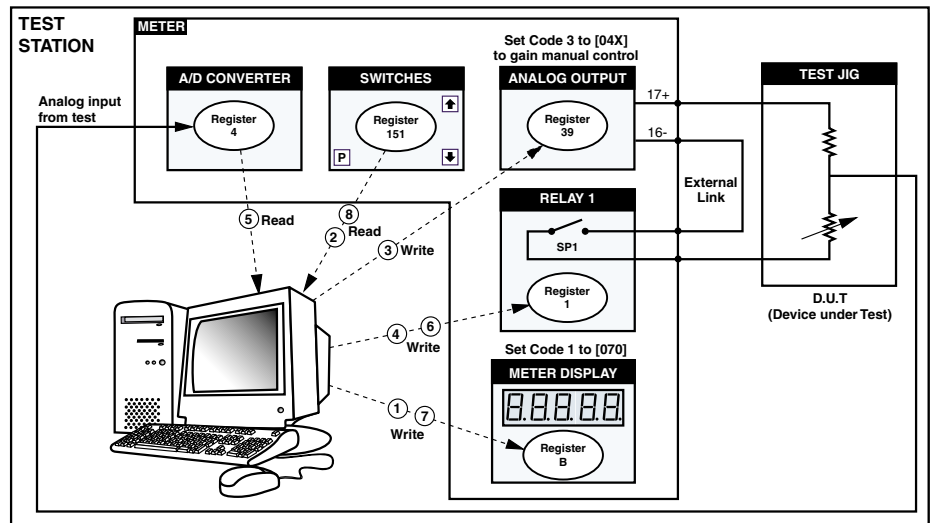

Figure 18 – Computer to Meter Control Mode Example

Master Mode

The master mode serial communications protocol is designed specifically for use with the macro features of Tiger 320 Series meters. The functionality and protocol of the master mode is largely defined by the user in the way in which a specific macro is written.

There are many different serial protocols in use and each have different string formats. Some strings include a special start character to signal the beginning of a new string while others use a special character to terminate the end of a string. Still others use a start character with a fixed string length.

The master mode is primarily designed for ASCII data, although any 8-bit data can be transmitted and received. As the name suggests, the meter normally assumes the role of **master** in this mode, but it can be used as a **slave** in certain circumstances.

To allow for maximum flexibility in as many applications as possible, the fixed functions of this mode are few but quite complex. It is therefore recommended that this mode is only used by persons who have a good working knowledge of serial communications in general and who are familiar with simple programming techniques.

Because this mode is only for use with a macro and because it involves specific macro commands, a full explanation of this mode is included in the Texmate's Tiger Development System Tutorial (NZ212).

Meter Programming Codes

The meter's programming codes are divided into two modes (see Figure 19):

- Main Programming Mode.
- Setpoint Programming Mode.

Each mode is accessible from the operational display. The meter is in the operational display when it is displaying a processed input signal.

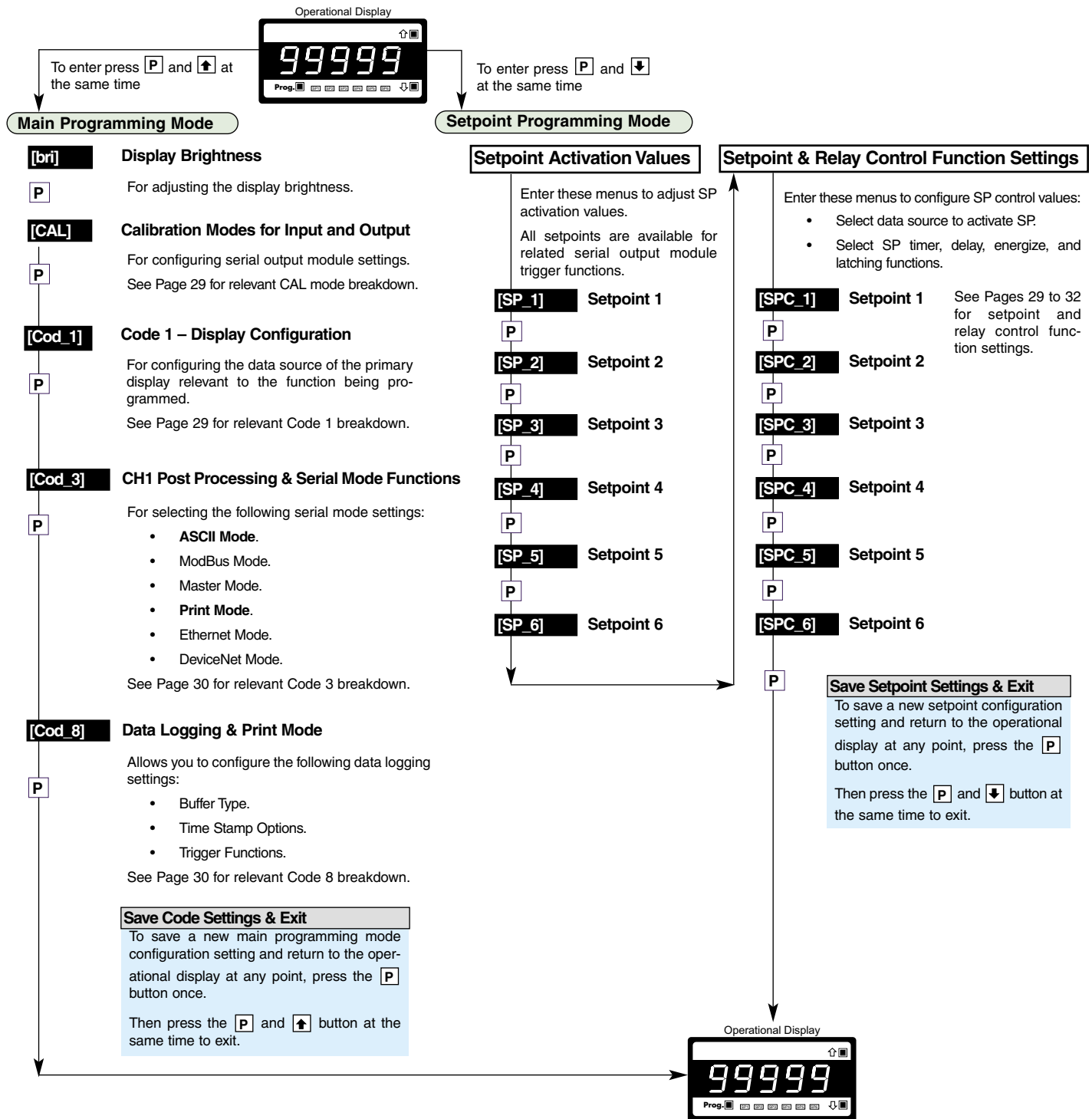

 The remaining codes (Codes 2, 4, 5, 6, 7, 9, and 10 if the meter is a bargraph display version) are still available but are not relevant to serial output programming.

Figure 19 – Programming Code List

Serial Output Configuration Programming Codes

Serial output module functions are configured in the following codes:

- Calibration Mode.
- Code 1.
- Code 3.
- Code 8.
- Setpoint Programming Mode.

Pressing the **P** and **↑** buttons at the same time enters the **main programming mode** which allows you to access Code 3 and Code 8.

To save a new configuration setting and return to the operational display, press the **P** button once and then press the **P** and **↑** buttons at the same time.

Pressing the **P** and **↓** buttons at the same time enters the **setpoint programming mode**. To save a new setpoint configuration setting and return to the operational display, press the **P** button once and then press the **P** and **↓** buttons at the same time.

CALIBRATION MODES FOR INPUT AND OUTPUT

FIRST DIGIT	SECOND DIGIT	THIRD DIGIT	
Functions Activated by Pressing the PROGRAM Button 1 Calibration Procedures 2 Related Calibration Functions 3 -	0 No function 1 On Demand TARE from the PROGRAM button 2 On Demand Single-point Calibration from the PROGRAM button (requires single input source) 3 On Demand Two-point Calibration from the PROGRAM button (requires dual input source) 4 On Demand Primary Input Compensation Mode from the PROGRAM button 5 On Demand Manual Loader Mode (no increase/decrease with HOLD active) 6 - 7 -	OBJECT FOR 2nd DIGIT 0 Result 1 Channel 1 2 Channel 2 3 Channel 3 4 Channel 4 5 - 6 - 7 -	
	0 Manual Calibration (requires NO input source) 1 Two-point Calibration (requires dual input source) 2 Calibrate Thermocouple (requires K type thermocouple input source) 3 Calibrate RTD (requires RTD 385 input source) 4 Calibrate Smart Input Module. <i>Note: This function is not available on all input modules</i> 5 Calibrate Analog Output mA/V Output Signal (requires multimeter connected to pins 16 and 17) 6 - 7 -		
	0 Serial Communications Properties 1 Set Auto Zero Maintenance for 3rd digit 2 Set Averaging Samples & Averaging Window for 3rd digit 3 Set K Factor & Cutoff for Totalizer 4 Setup 32-point Linearization Tables 5 Scale Analog Output LOW/HIGH (zero/span) Display Readings 6 - 7 -		

Programming Tip

The time delay settings are applicable to all serial modes except the ASCII Mode (See Code 3).

The ASCII Mode uses message terminating characters with the following time delays:

* = 2 milliseconds.
 \$ = 50 milliseconds.

CODE 1 – DISPLAY CONFIGURATION: SELECT DATA SOURCE FOR SERIAL OUTPUT

FIRST DIGIT	SECOND DIGIT	THIRD DIGIT
FRONT PANEL ANNUCIATORS 0 ON when Setpoints are ON (relay energized) 1 ON when Setpoints are OFF (relay de-energized) 2 Always OFF. 3 LED SP1 ON indicates RISING signal trend. LED SP2 ON indicates FALLING signal trend.	DATA DISPLAY SOURCE 0 Normal Display Mode (i.e. operational display shows selected register) updates every 0.5 seconds 1 Manual Loader Mode (Direct Display). See Note 1 2 Update at sample rate selected in Code 2 3 - 4 - 5 Select data source as per 3rd digit 6 Select display format as per 3rd digit 7 Select text character as per 3rd digit	SELECT DATA SOURCE FOR 0 Primary Display 1 Second Display. See Note 2 2 Third Display. See Note 2 3 Peak/Valley 4 Analog Output 1 5 Analog Output 2 6 Totalizer 1 7 Totalizer 2

Select Data Source

The **↓** button takes you forward through the Destination and Source registers, the **↑** button takes you back to [oFF].

Constant pressure on the **↓** button moves through the Registers Menu one register at a time until you get to ten, then it jumps in multiples of 10, until you reach 100, then it jumps in multiples of 100. Stopping and starting again resumes single steps forward.

Note 1:
Upper and lower limits can be set in SP5 and SP6 of the setpoint programming mode.

Note 2:
These options are only for use with meters that have more than one display. With bargraph meters the PRIMARY display is the digital display, and the SECONDARY display is the bargraph display.

Select Data Source

P Sourc [oFF]

[rESL] [diSP] [1 to 239] [AUx_5] [AUx_4] [AUx_3] [AUx_2] [AUx_1] [Ch1] [Ch2] [Ch3] [Ch4] [tot_1] [tot_2] [PEAK] [VALEY] [tArE]

CODE 3 – CHANNEL 1 FUNCTIONS (POST PROCESSING & SERIAL MODE)

FIRST DIGIT
CHANNEL 1 POST PROCESSING
0 Direct Display of Input (no processing)
1 Square Root of Channel 1
2 Inverse of Channel 1
3 -

SECOND DIGIT
32-POINT LINEARIZATION FOR CHANNEL 1
0 No Linearization on CH1
1 32-point Linearization on CH1 using Table 1
2 32-point Linearization on CH1 using Table 2. See Note 5
3 32-point Linearization on CH1 using Table 3. See Note 5
4 32-point Linearization on CH1 using Table 4. See Note 5
5 125-point Linearization on CH1 (Tables 1 to 4 cascaded). See Note 5
6 32-point Linearization on CH1 (Tables 1 to 4 selected from the rear pins of selected input modules). The selected table is not available if CH2, CH3, or CH4 is operating in the analog output mode. CH1 must be set to Voltage, Current in Code 2 [X0X]. See Note 5
7 -

Note:
All linearization tables are set up in the Calibration Mode [24X].

THIRD DIGIT
SERIAL MODE
0 ASCII Mode
1 Modbus Mode
2 Master mode (used to customize print mode protocols via macro)
3 Print Mode
4 Ethernet Mode. See Note 6
5 Devicenet Mode (requires Devicenet hardware module). See Note 6

Note 5:
If only 4 kB memory installed, functions 2 to 6 are not available in:

- Code 3 second digit.
- Code 4 third digit.
- Code 7 second digit.

Note 6:
These functions are not available on all models and in some cases require additional hardware.

CODE 8 – DATA LOGGING AND PRINT MODE OPTIONS

FIRST DIGIT
DATA LOG BUFFER TYPE
0 No Data Logging
1 Cyclic Buffer
2 Linear FIFO Buffer.
3 Reset Buffer Number to 0.

Note:
Setting Code 8 to [3XX] resets the data log buffer to 0. Once reset, Code 8 must be set back to the required data log buffer setting.

SECOND DIGIT
DATE & TIME STAMP OPTIONS
0 Printer Format – No time stamp with print/log
1 Printer Format – Time stamp format 1 [Mth-Day-Yr Hrs:Min:Sec] (with <CR><LF>)
2 Printer Format – Time stamp format 2 [Day-Mth-Yr Hrs:Min:Sec] (with <CR><LF>)
3 Printer Format – Time stamp format 3 [Hrs:Min:Sec] (with <CR><LF>)
4 Spreadsheet Format – No time stamp with print/log
5 Spreadsheet Format – Time stamp format 1 [Mth-Day-Yr Hrs:Min:Sec]
6 Spreadsheet Format – Time stamp format 2 [Day-Mth-Yr Hrs:Min:Sec]
7 Spreadsheet Format – Time stamp format 3 [Hrs:Min:Sec]

ALL ABOVE ARE REAL-TIME CLOCK OPTIONS

THIRD DIGIT
LOG OR PRINT TRIGGER
0 No trigger
1 Trigger on Demand from PROGRAM Button
2 Trigger on Demand from F1 Button
3 Trigger on Demand from F2 Button
4 Trigger on Demand from HOLD Pin
5 Trigger on Demand from LOCK Pin
6 -
7 -

Note:
Log and/or Print will only trigger if enabled.

SETPOINT PROGRAMMING MODE – SETPOINT CONTROL SETTINGS

FIRST DIGIT
Relay Energize Function
0 Energized ABOVE setpoint value.
1 Energized BELOW setpoint value.
2 Energized ABOVE setpoint value with FALLING INPUT SIGNAL INITIAL START-UP INHIBIT.
3 Energized BELOW setpoint value with RISING INPUT SIGNAL INITIAL START-UP INHIBIT.

SECOND DIGIT
SP Activation Source
0 Activate Setpoint Source from Selected Register
1 Select Source for Setpoint

Note:
[X1X] is a register selection procedure only. To finish, reset to [X0X] to activate the selection, or reset to 2-7 as required for digital input selection.

2 Digital Input – Capture Pin
3 Digital Input – D1
4 Digital Input – D2
5 Digital Input – D3
6 HOLD Pin
7 LOCK Pin

THIRD DIGIT
SP Delay & Timing Functions
0 No Latching
1 Relay Latched
2 Manual Relay Reset
3 Relay Latched with Manual Relay Reset
4 Relay Latched Off
5 Hysteresis, Deviation & PID Mode
6 Timer Modes: • Normal Delay. • Repeat ON. • Pulse ON. • 1-Shot ON. • Repeat OFF. • Pulse OFF. • 1-Shot OFF.
7 Advanced Functions Mode: • Reset Trigger. • Reset Destination. • Reset Mode. • Reset Constant. • Trigger Print from SP. • Trigger Log from SP. • Annunciator Flashing & SP Tracking.

Note:
With PID active, all SP1 functions set in [XX6] are not functional.

Note:
[XX5], [XX6], and [XX7] are set up procedure settings only. To finish, reset to 0-4 as required for setpoint latching and relay reset modes.

See Set Up Hysteresis, Deviation, and PID Mode Settings on Page 31

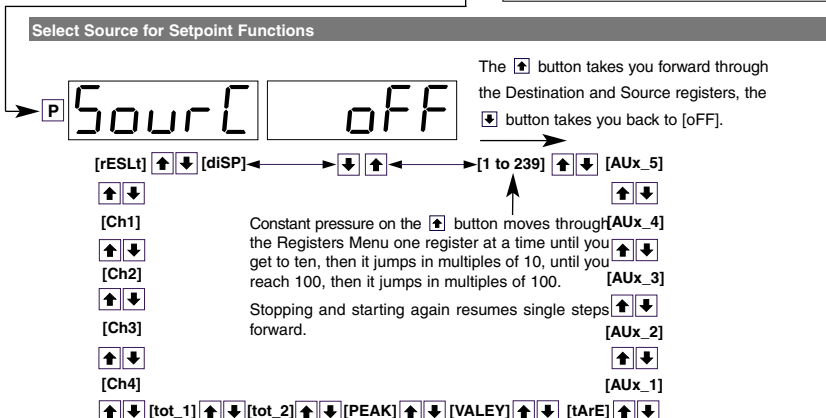

Setpoint & Relay Control Settings Diagram (Continued)

Set Up Hysteresis, Deviation, and PID Mode Settings



Programming Tip

If you do not require any of the functions in this mode, ensure it is set to:

Mode OFF

Basic Level

Select: Mode/OFF

Intermediate or Advanced Level

Select Hysteresis, Deviation or PID Mode and adjust to required setting.

SPC_1 or SPC_2, third digit set to [XX5]

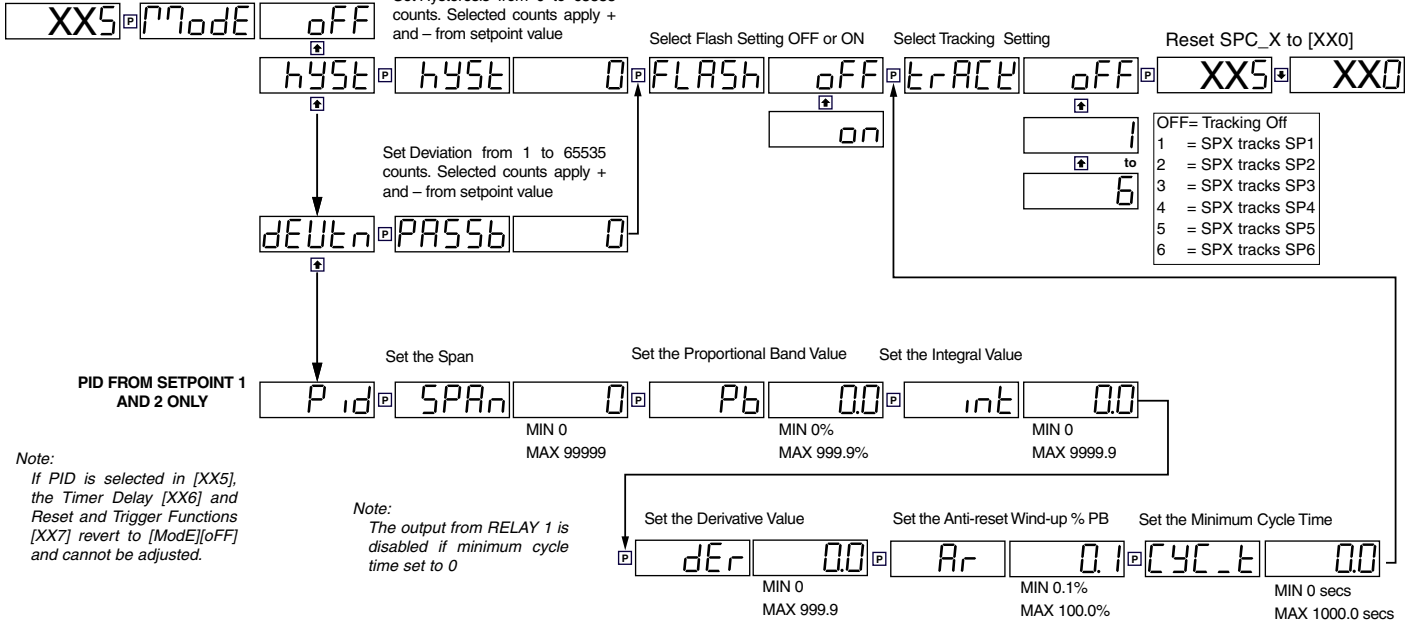

Set Up Timer Mode Settings



Programming Tip

If you do not require any of the functions in this mode, ensure it is set to:

Timer OFF

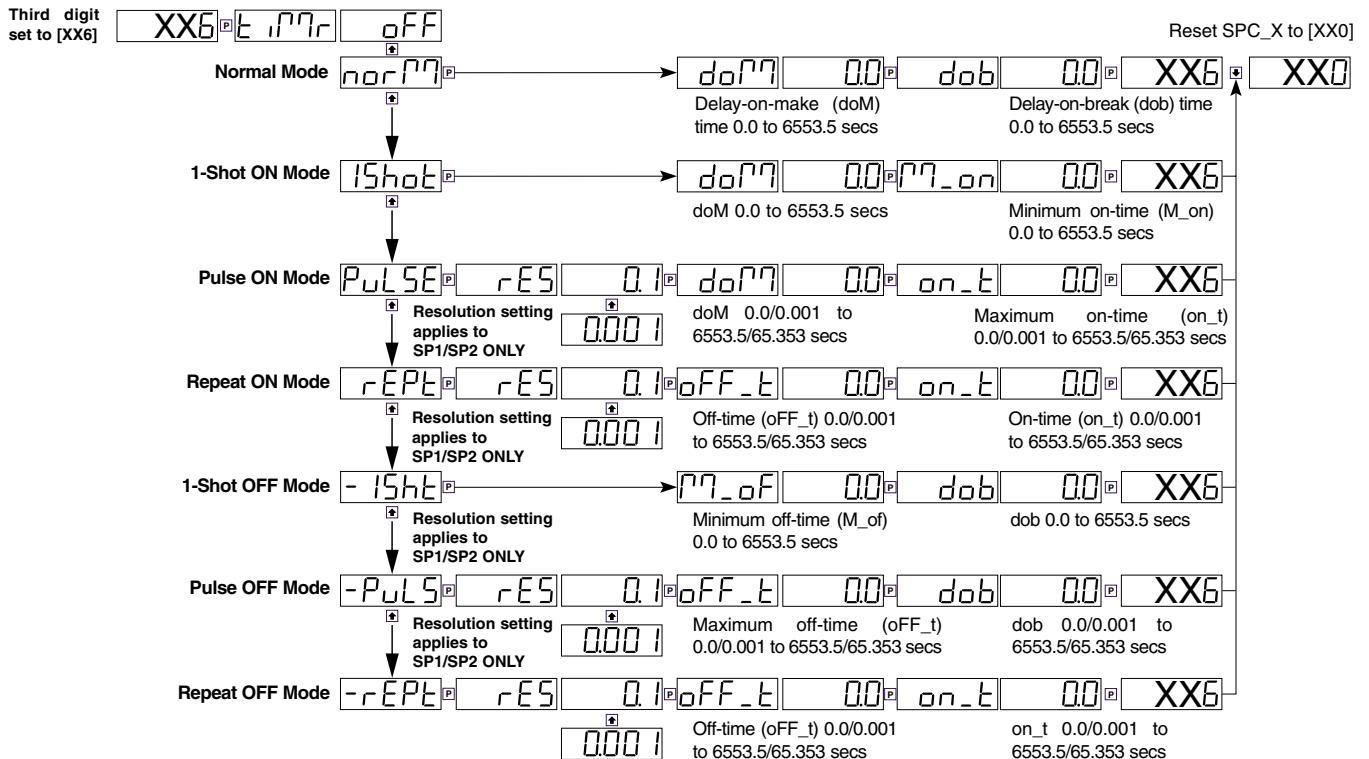

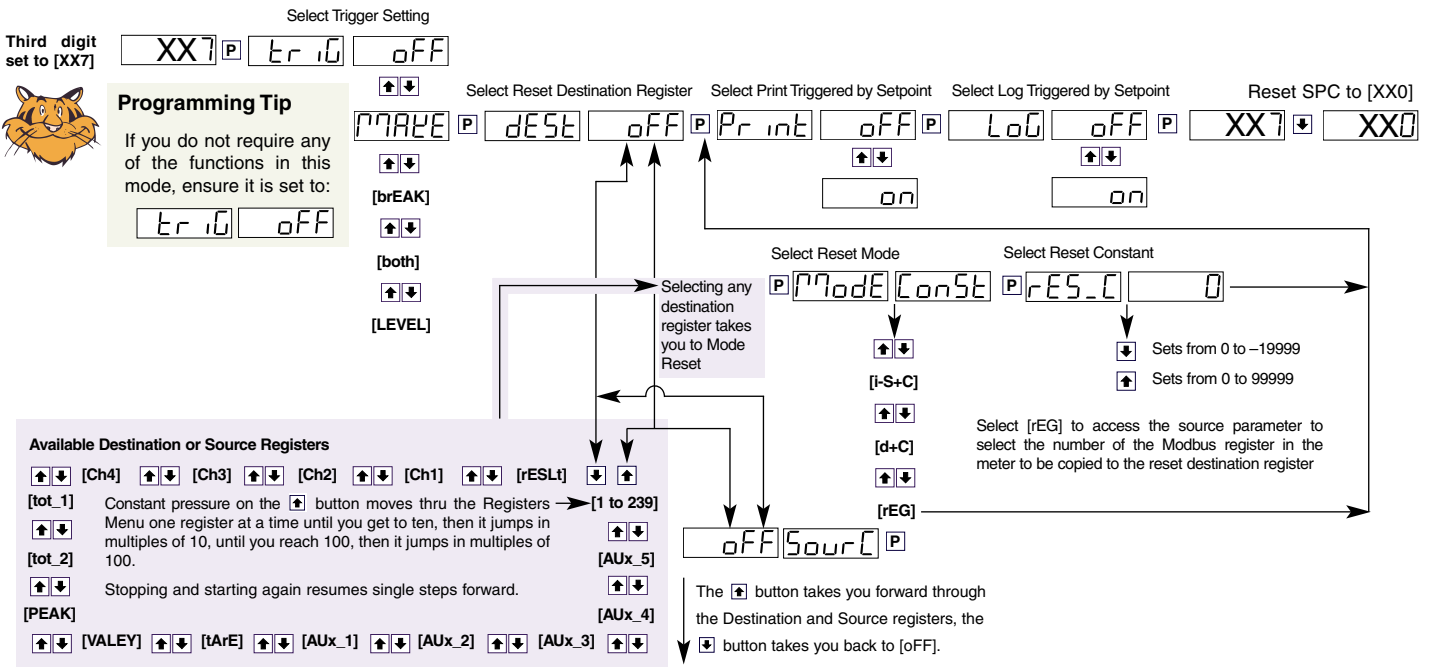

Component Layout

Figure 20 shows all circuit boards in an exploded assembly view of a standard DI case size Tiger 320 Series meter without the meter case.

The serial output module is mounted on the component side of the output carrier board.

The Ethernet output carrier board has an RJ-45 socket using 10/100 Base-T.

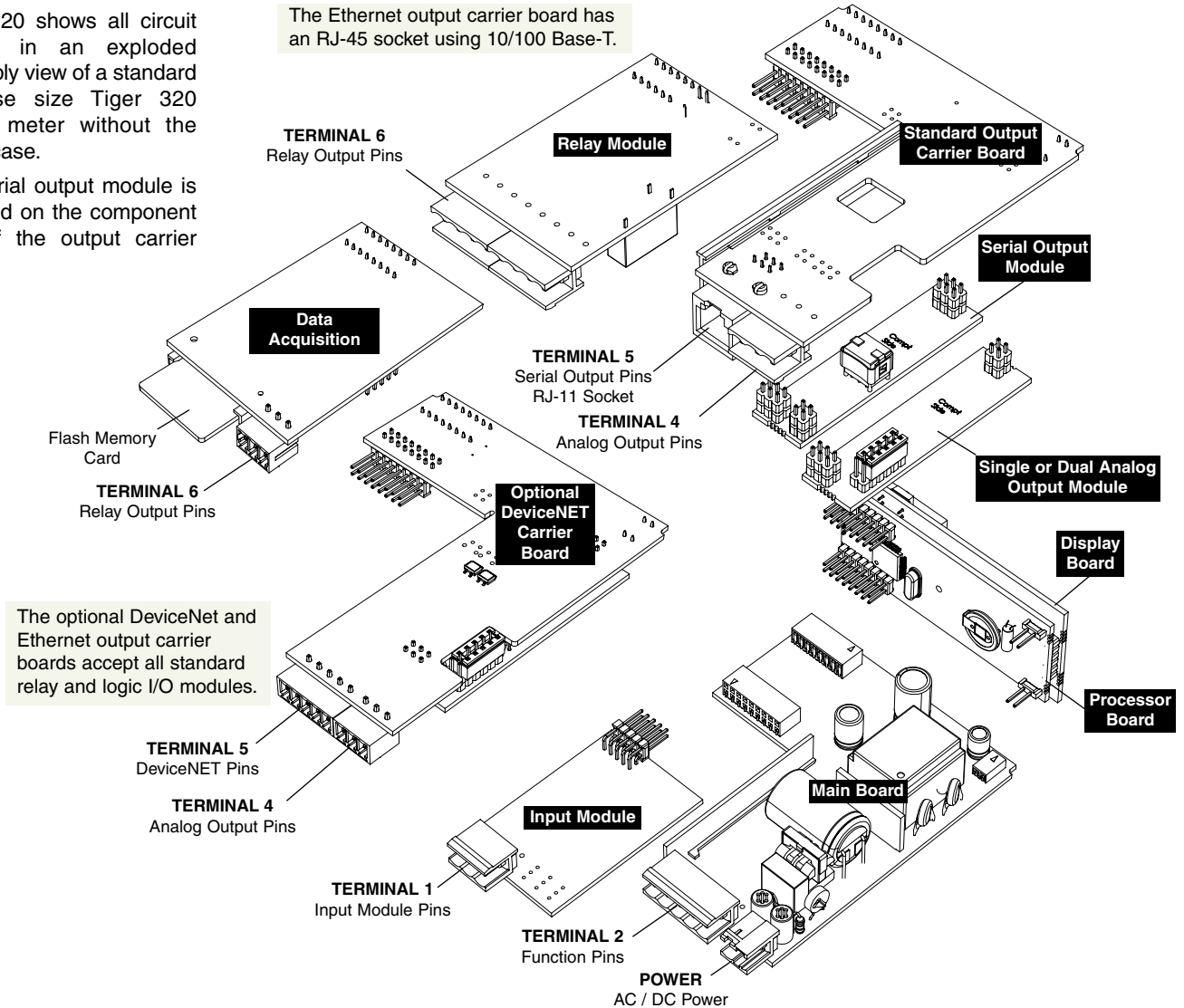

Figure 20 – Exploded View of Meter Modular Boards

Standard Procedures

Following are the standard procedures required to configure the meter to perform the various related serial output communications functions.

1 SERIAL COMMUNICATIONS INTERFACE SETUP PROCEDURES

- 1) Connect the meter for RS-232 interface.
OR
- 2) Connect the meter for RS-485 interface.

See Serial Communications Interface Setup Procedures on Pages 39 and 40 for examples on connecting to RS-232 or RS-485 interface.

2 SERIAL COMMUNICATIONS SETTINGS CONFIGURATION PROCEDURES

Set Serial Communications Properties (CALIBRATION MODE)

- 1) Set the meter's serial communications properties.

See Serial Communications Settings Configuration Procedures on Pages 41 and 42 for an example of how to set these properties.

Select a Serial Mode (CODE 3)

- 1) Set the meter to the ASCII Mode (Code 3 – XX0).
- 2) Set the meter to the MODBUS Mode (Code 3 – XX1).
- 3) Set the meter to the PRINT Mode (Code 3 – XX3).

See Serial Communications Settings Configuration Procedures on Page 42 for an example on setting these modes.



Note:

The meter can only be set to one of these modes at any time.

3 DATA LOGGING SETTINGS CONFIGURATION PROCEDURES

Configure Data Logging Settings (CODE 8)

- 1) Select data log buffer type (1st digit in Code 8).
- 2) Select time stamp (2nd digit in Code 8).
- 3) Select ON DEMAND trigger functions for log or print (3rd digit in Code 8).

See Data Logging Settings Configuration Procedures on Page 43 for examples on setting these modes.

4 TERMINAL PROGRAM CONFIGURATION & USE PROCEDURES

Writing to and reading from meter registers can be done using any terminal emulation program. We have chosen Microsoft HyperTerminal as an example because it is widely available.

EXAMPLE – Microsoft HyperTerminal

- ➔ 1) Configure the HyperTerminal properties.
- ➔ 2) Check communication between the meter and the PC.
- ➔ 3) Configure the print string by writing to register X.
- ➔ 4) Set the meter to the PRINT Mode.
- ➔ 5) Type **P** to download data.
- ➔ 6) Capture the measurement data onto the PC.
- ➔ 7) Process the measurement data on the PC in a spreadsheet.

See Terminal Program Configuration & Use Procedures on Pages 44 to 47 for an example on how to configure the HyperTerminal program properties, as well as writing to and reading from meter registers using the program.

5 AUTOMATIC TRIGGER SOURCE CONFIGURATION PROCEDURES

Configure an Automatic Trigger Source (Setpoint Programming Mode)

- ➔ 1) Select a trigger source.
Enter the setpoint programming mode and select the setpoint source trigger (SPC_X set to **X1X**) from the available registers.
- ➔ 2) Configure the source trigger control settings.
 - Set setpoint activation value.
 - Configure timer modes (SPC_X set to **XX6**).
 - Configure automatic trigger settings (SPC_X set to **XX7**).

See Automatic Trigger Source Configuration Procedures on Pages 47 to 49 for an example on configuring trigger source settings using a setpoint.

Example Application Procedures

The following procedures are examples of the functions available to the meter when a serial output module (and in some cases other hardware) is installed in the meter.

Each example generally uses one or more of the standard procedures previously described.

1 DATA LOGGING

Log data in the meter in the following steps:

- ➔ 1) Configure the meter's serial communications properties (Calibration Mode).
See Serial Communications Settings Configuration Procedures on Pages 401 and 42 for an example of how to set these properties.
- ➔ 2) Configure the data logging settings (Code 8):
 - Select the data log buffer type.
 - Select the time stamp.
 - Select the trigger source.*See Data Logging Settings Configuration Procedures on Page 43 for examples on setting these modes.*
- ➔ 3) Set the meter in the ASCII Mode (Code 3 – XX0).
See Serial Communications Settings Configuration Procedures on Pages 41 and 42 for examples on setting these modes.
- ➔ 4) Configure trigger source settings:
 - Select a trigger source
 - Configure the trigger source control settings (if a setpoint has been used).*See Automatic Trigger Source Configuration Procedures on Pages 47 to 49 for an example on configuring trigger source settings using a setpoint.*

Retrieving Logged Data via ASCII MODE using HyperTerminal

Retrieve logged data via a terminal program in the following steps:

- ➔ 1) Configure the meter's serial communications properties.
Set the Calibration Mode to [20X].
See Serial Communications Settings Configuration Procedures on Pages 41 and 42.
- ➔ 2) Configure the meter to the ASCII mode so that it can communicate with the PC.
Set Code 3 to [XX0] in the meter's main programming mode.
See Serial Communications Settings Configuration Procedures on Pages 41 and 42.
- ➔ 3) Configure the meter's time stamp format if required.
Select a date and time stamp option in the 2nd digit of Code 8.
See Data Logging Settings Configuration Procedures on Page 43.
- ➔ 4) Set the terminal program's properties.
This is done in the terminal program.
See Terminal Program Properties Configuration Procedures on Pages 44 to 47.
- ➔ 5) Check that communication is established between the meter and the PC.
Write **SR*** in the terminal program.
The screen displays the current meter reading.
- ➔ 6) Write **SR722*** to read the next sample of logged data.
OR
Write **SR727*** to read the whole buffer of logged data.
The data from the selected register is captured in the terminal program.

Example – Data Printing via PRINT MODE

The following example describes a simple method of printing data using the meter's PRINT Mode.

In this example the meter is used to measure and record the breaking point of a cable using a strain gage. The meter is programmed to record the display value data from register 2 and the peak value data from register 12. Setpoint 1 is set to a specific amount of tension (50 counts on the meter display) as the starting point for the meter to begin recording the measurement data. The meter is configured to send the measurement data at one second intervals. As the cable is stretched and the tension increases, the meter sends the current display value and peak value every second until the cable snaps, dropping the tension below the 50 counts set for SP1.

Hardware Requirements and Setup

The data printing operation must be set up and carried out in the following basic steps. The procedure requires the following equipment:

- Tiger 320 Series meter.
- PC running terminal program (HyperTerminal in our example) connected to the meter through the serial port.
See Serial Communications Settings Configuration Procedures on Pages 41 and 42.
- Printer connected to the meter through the serial port (optional).

**Note:**

The printer and the PC cannot be connected to the meter at the same time. If the measurement data is to be recorded by the printer, the meter is connected to the PC and the meter and Terminal program properties set up. After the meter and Terminal program properties are set up, the PC can then be disconnected from the meter and the printer connected.

Example – Data Printing via PRINT MODEcontinued

Print data from the meter to a serial printer in the following steps:

- ➔ 1) Configure the meter's serial communications properties.
Set the Calibration Mode to [20X].
See Serial Communications Settings Configuration Procedures on Pages 41 and 42.
- ➔ 2) Configure the meter to the ASCII mode so that it can communicate with the PC.
Set Code 3 to [XX0] in the meter's main programming mode.
See Serial Communications Settings Configuration Procedures on Pages 41 and 42.
- ➔ 3) Configure the meter's time stamp format with an HRS:MIN:SEC printer format time stamp with no trigger.
Set Code 8 to [030] in the meter's main programming mode.
See Data Logging Settings Configuration Procedures on Page 43.
- ➔ 4) Choose a setpoint and set the trigger value to 50 counts (for example SP1).
Set [SP_1] in the Setpoint Activation Values Mode to [50].
See Automatic Trigger Source Configuration Procedures on Pages 47 to 49.
- ➔ 5) Select an activation source for SP1.
Set [SPC_1] to [X1X] and select [Ch3].
See Automatic Trigger Source Configuration Procedures on Pages 47 to 49.
- ➔ 6) Set a 1 second repeat delay for SP1.
Set [SPC_1] to [XX6] and select the repeat delay timer [rEPT]. Set the repeat delay timer to 0 sec OFF time and 1 sec ON time.
See Automatic Trigger Source Configuration Procedures on Pages 47 to 49.
- ➔ 7) Set the terminal program's properties.
This is done in the terminal program.
See Terminal Program Configuration and Use Procedures on Pages 44 to 47.
- ➔ 8) Check that communication is established between the meter and the PC.
Write **SR*** in the terminal program.
The screen displays the current meter reading.
- ➔ 9) Select registers 2 and 12 to download the measurement data from the meter to the terminal program.
Write **SWX ~2 ~12*** in the terminal program.
- ➔ 10) Set the meter to the PRINT Mode to allow the meter to send the measurement data to the PC.
Set Code 3 to [XX3] in the meter's main programming mode.
The measurement data is now automatically sent directly to a serial printer.
See Serial Communications Settings Configuration Procedures on Pages 41 and 42.



Note:

The data results can also be captured through the terminal program on a PC, where the captured text can be imported into a spreadsheet such as Microsoft Excel and used to build graphs.

3 METER TO METER COMMUNICATION CONFIGURATION PROCEDURES

Example – Configuring an Accurate Second Display

The following procedures are a guide to setting up communication between two Tiger 320 Series meters. The example describes how to configure the meters to display the data measured and displayed by a meter in a process environment at another meter in a remote location, such as a plant control room.

Both meters are configured in the following main steps:

- ➔ 1) Calibrate both meters.
See Calibration Mode Procedures Supplement for calibration details.
- ➔ 2) Configure the **master** meter to display the processed data result:
 - Set Code 1 to [X50] to enter the Select Data Source Mode for the Primary Display.
 - Set the Select Data Source Mode to [Ch1].
- ➔ 3) Configure the **slave** meter to display the processed data from the master meter:
 - Set Code 1 to [X50] to enter the Select Data Source Mode for the Primary Display.
 - Set the Select Data Source Mode to [rESLt].
- ➔ 4) Connect the **master** meter to a PC through the serial port.
See Serial Communications Interface Configuration Procedures on Pages 39 and 40.
- ➔ 5) Write to the **master** meter's register X to print the processed data channel 1 to the **slave** meter's result register.
Write: **SWX SW2 ~3*** in the terminal program.

This means that the **master** meter writes the processed data result to its register X. With the **master** meter set up in the print mode, it will print the data stored in register X to the **slave** meter. The **slave** meter must be set up in the ASCII mode to receive the ASCII formatted data from the **master** meter.
- ➔ 6) Connect both meters through the serial port (See Figure 21).
- ➔ 7) Configure the **master** meter in the **print** mode. Set Code 3 to [XX3].
See Serial Communications Settings Configuration Procedures on Pages 41 and 42.
- ➔ 8) Configure the **slave** meter in the **ASCII** mode. Set Code 3 to [XX0].
See Serial Communications Settings Configuration Procedures on Pages 41 and 42.

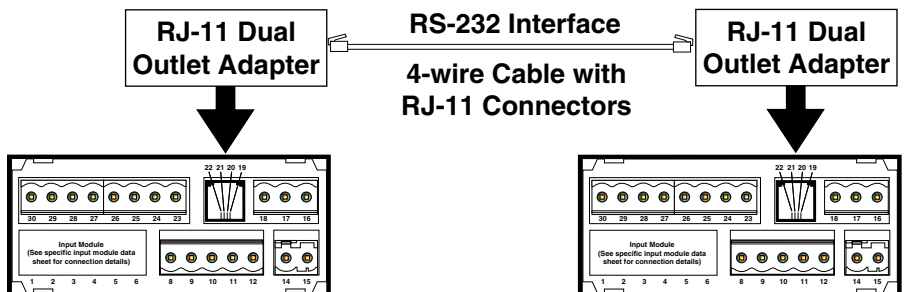

Figure 21 – Meter to Meter Connection through Serial Ports

Example – Heater Testing Station

Hardware Requirements

To carry out the heater testing station example, the procedure requires the following equipment:

- Tiger 320 Series meter.
- PC running a customer supplied test program (similar to a Terminal emulation program) connected to the meter through the serial port.

See *Serial Communications Interface Configuration Procedures on Pages 39 and 40*.



Note:

The example application also requires a test jig to be connected to each meter to make up individual testing stations.

Heater Testing Station Setup

The test is controlled by the PC running a suitable test program. Each Tiger 320 Series meter is used as an interface between the PC and the test jig.

In our example application, the PC uses the meter functions and the test program to manually control the meter's inputs and outputs by writing to or reading from the meter's registers.

Testing Process

Meter Configuration

To gain manual control of the meter's functions through the PC, the following settings must be programmed into each meter before starting the test process (see the diagrams on Page 27 and 28 for a breakdown of these settings):

- 1) Set Code 1 to [X54].

Enter the Select Data Source Mode and select register 39 as the source of data for Analog Output 1.

- 2) Set Code 1 to [010].

This provides direct control over analog output 1.

Test Process

The following procedure describes the steps performed during a test on a heating element in test station 1. All read or write instructions are carried out by the PC using a test program. Steps 3 to 7 can be repeated for further test stations. The numbered steps correspond to the circled numbers in Figure 22.

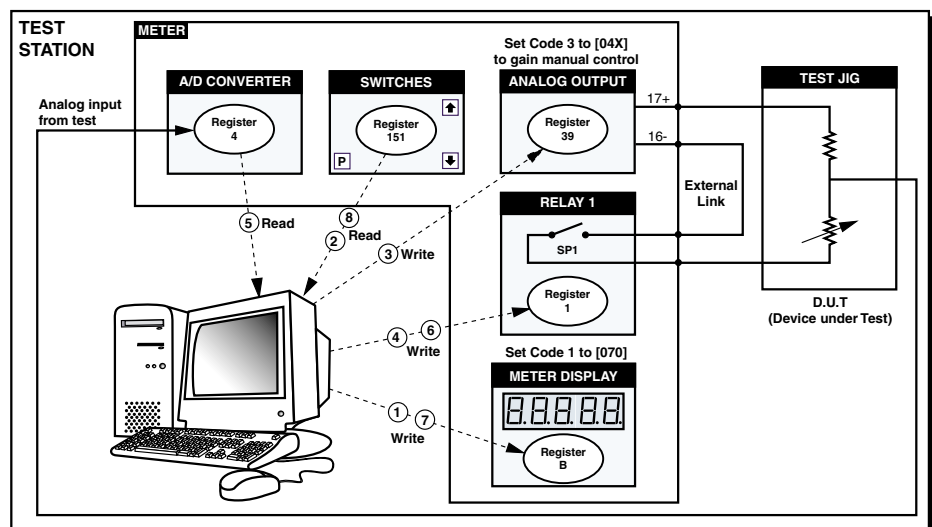

Figure 22 – Computer to Meter Control Mode Example

Example – Heater Testing Station continued

- 1) After the testing station has been set up and the the heating element has been installed into its jig (testing stations), start the test program on the PC.
As a starting point we will assume that the test program writes **start** to register B in the test station meter. The meter displays [StArt] for 3 seconds.
- 2) Press the PROGRAM button on the meter.
The PC reads register 151 in the meter, letting the PC know that it is safe to start the test.
- 3) The PC writes **5.000** to register 39 in the meter.
This sends a 5 V signal to the analog output. The 5 V output signal is now at the meter's connector pin 17 (analog output 1).
- 4) The PC writes **257** to register 1 to turn relay 1 ON. The 5 V signal now passes through the test.
The output voltage of the test and its value appears in register 4.
- 5) The PC reads the output voltage from register 4 to see if the output voltage from the test is within the PASS or FAIL limits.
- 6) The PC writes **256** to register 1 to turn relay 1 OFF.
- 7) If register 4 is in the PASS region, the PC writes **pass** to the meter's display through register B. If the voltage at register 4 is not in the PASS region, the PC writes **fail** to the meter's display through register B.
With the results of the first test, take action accordingly.
- 8) To continue testing on a second test station, press the PROGRAM button on the second meter to initiate the test at test station 2.

Serial Communications Interface Setup Procedures

RS-232 Interface Setup Procedures

Carry out the following procedures to establish communications between the meter and a PC using RS-232 interface. See Figures 6, 8, 9 and Tables 7 and 8):

STEP A Connect the Meter to the PC

- 1) Connect one end of the standard 4-wire telephone cable to the RJ-11 serial output port on the meter.
- 2) Connect the other end of the standard 4-wire telephone cable to the RJ-11 to DB-25 interface connector.
- 3) Connect the DB-25 interface connector to the serial port of the PC.

STEP B Make Sure the PC and Meter are Powered Up

- 1) Make sure the meter is powered up.
- 2) Make sure the PC is powered up.

STEP C Check Communication Between the PC and the Meter

- 1) Make sure the terminal program is running.
- 2) Check that communication is established between the meter and the PC:
Write **SR*** in the terminal program.
The screen displays the current meter reading.

RS-485 Interface Setup Procedures

Carry out the following procedures to establish communications between a number of meters and a PC using RS-485 interface. See Figures 7, 8, 9 and Tables 7 and 8):

STEP A Connect the Meters Together

- 1) Connect the meters together using the 2-wire telephone cables as shown in Figure 7.



Note:

Up to 64 meters can be connected together. The meters can be connected together in series or parallel using RJ-11 type connectors or hardwiring (can only be hardwired if each meter has a screw terminal instead of an RJ-11 connector). Figure 7 has the meters connected in series using RJ-11 type connectors.

STEP B Connect the Meter to the Texmate Isolated Converter

- 1) Connect one end of the standard 2-wire telephone cable to the RJ-11 serial output port on the first meter.
- 2) Connect the other end of the standard 2-wire telephone cable to the RJ-11 to female DB-25 interface connector.
- 3) Connect the RJ-11 to female DB-25 interface connector to the end of the Texmate isolated converter marked: **LOGIC OUTPUT FROM METER**.
- 4) Connect the Texmate isolated converter to the DB-25 to DB-9 interface connector.
- 5) Connect the DB-9 end of the DB-25 to DB-9 interface connector to the serial port of the PC.

STEP C Check Communication Between the PC and the Meter

- 1) Make sure the terminal program is running.
- 2) Check that communication is established between the meter and the PC:

Write **SR*** in the terminal program.

The screen displays the current meter reading.

Serial Communications Settings Configuration Procedures

Configure Serial Communications Properties

START HERE

Configure Serial Communications Properties

Step 1

Enter the Brightness Mode

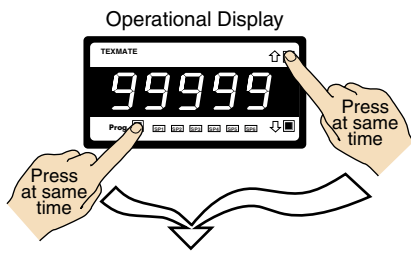

Step 2

Pass the Brightness Mode, enter the Calibration Mode

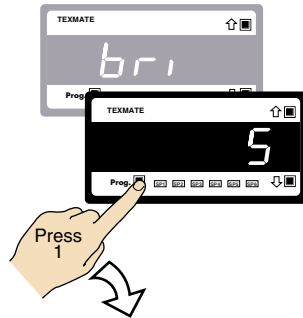

Step 3

Set Calibration Mode to [20X]:
1st Digit = 2 Selects Related Calibration Functions
2nd Digit = 0 Selects Serial Comms. Properties
3rd Digit = X Not relevant

Example
Enter CAL and select channel CH1.

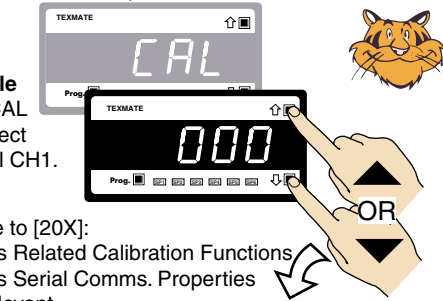

Step 4

Enter the Baud Rate setting menu

Baud Rates:
600
1200
2400
4800
9600
19200
38400

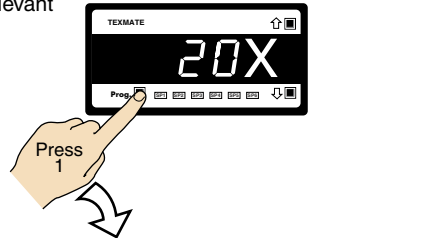

Step 5

Set the baud rate to [2400]



Step 6

Save the baud rate. Enter the Parity setting menu



From Step 6

Step 7

Select parity setting

Parity Settings:
OFF
ODD
EVEN

Example

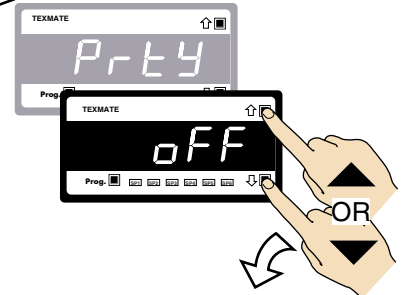

Step 8

Save the parity setting

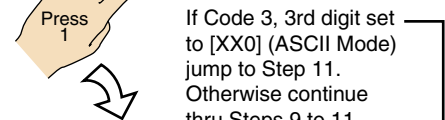

If Code 3, 3rd digit set to [XX0] (ASCII Mode) jump to Step 11. Otherwise continue thru Steps 9 to 11

Programming Tip

The ASCII Mode uses the following terminating characters with built-in time delay:

\$ = 50 milliseconds
* = 2 milliseconds

Step 9

Set Time Delay

Time Delay Settings:
2 ms
20 ms
50 ms
100 ms

Example
Set Time Delay to 50 msec

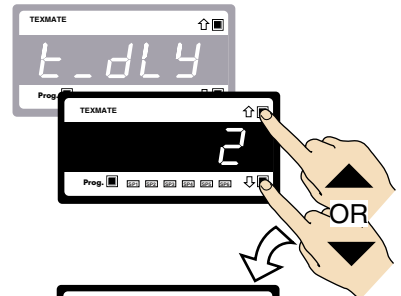

Step 10

Save the time delay setting. Enter Address setting menu



Step 11

Save the address setting. Return to the Calibration Mode [CAL]

Address Settings:
1 to 255

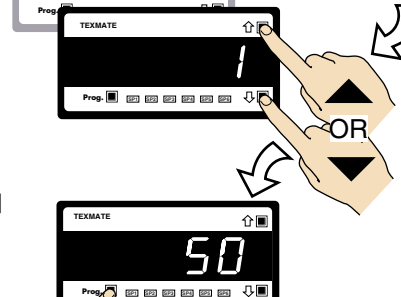

Step 12

Save the address setting. Return to the Calibration Mode [CAL]



Serial Output Module Settings Procedure

continued on next page (Step 13).

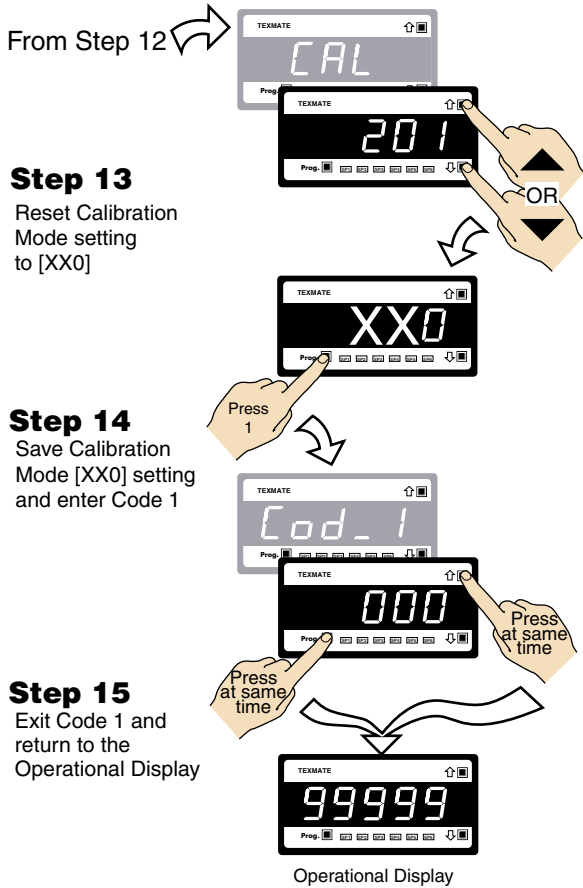

Operational Display

START HERE

Select a Serial Mode

Step 1
Enter the Brightness Mode

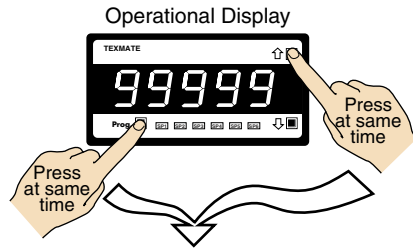

Step 2
Pass the Brightness Mode thru to Code 2 and enter Code 3

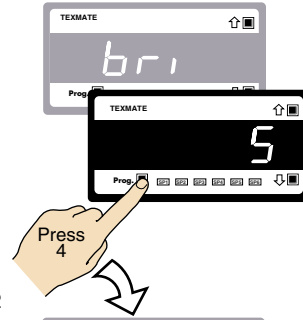

Example
Enter Code 3 and select a Serial Mode, e.g. ASCII.

Step 3

Set Code 3 to [XX0]:
1st Digit = X Not relevant
2nd Digit = X Not relevant
3rd Digit = 0 Selects ASCII Mode

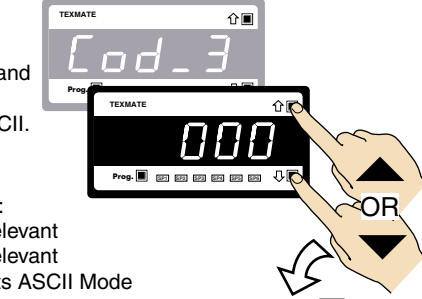

- 0 ASCII Mode
- 1 Modbus Mode
- 2 Master Mode
- 3 PRINT Mode
- 4 Ethernet Mode
- 5 DeviceNet Mode

Step 4
Save Code 3 settings

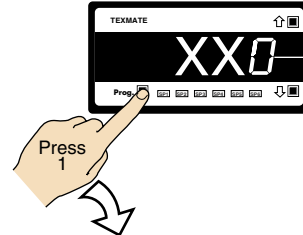

Step 5
Exit Code 4 and return to the Operational Display

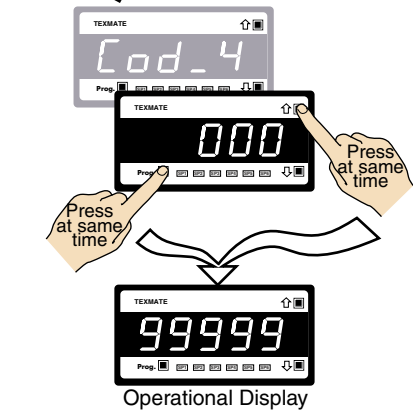

Data Logging Settings Configuration Procedures

Example

The following example procedures describe how to configure the data logging functions: buffer type, time stamp, and ON DEMAND trigger:

- 1st digit = Buffer Type: Cyclic.
- 2nd digit = Time Stamp: Spreadsheet Format – Time Stamp Format 1 [Day:Mth:Yr,Hrs:Min:Sec].
- 3rd digit = ON DEMAND Trigger: Trigger ON DEMAND from PROGRAM button.

FIRST DIGIT	SECOND DIGIT	THIRD DIGIT
CODE 8 – DATA LOGGING AND PRINT MODE OPTIONS		
DATA LOG BUFFER TYPE	DATE & TIME STAMP OPTIONS	LOG OR PRINT TRIGGER
0 No Data Logging 1 Cyclic Buffer 2 Linear FIFO Buffer. 3 Reset Buffer Number to 0. <i>Note:</i> Setting Code 8 to [3XX] resets the data log buffer to 0. Once reset, Code 8 must be set back to the required data log buffer setting.	0 Printer Format – No time stamp with print/log 1 Printer Format – Time stamp format 1 [Mth-Day-Yr Hrs:Min:Sec] (with <CR><LF>) 2 Printer Format – Time stamp format 2 [Day-Mth-Yr Hrs:Min:Sec] (with <CR><LF>) 3 Printer Format – Time stamp format 3 [Hrs:Min:Sec] (with <CR><LF>) 4 Spreadsheet Format – No time stamp with print/log 5 Spreadsheet Format – Time stamp format 1 [Mth-Day-Yr Hrs:Min:Sec] 6 Spreadsheet Format – Time stamp format 2 [Day-Mth-Yr Hrs:Min:Sec] 7 Spreadsheet Format – Time stamp format 3 [Hrs:Min:Sec] ALL ABOVE ARE REAL-TIME CLOCK OPTIONS	0 No trigger 1 Trigger on Demand from PROGRAM Button 2 Trigger on Demand from F1 Button 3 Trigger on Demand from F2 Button 4 Trigger on Demand from HOLD Pin 5 Trigger on Demand from LOCK Pin 6 - 7 - <i>Note:</i> Log and/or Print will only trigger if enabled.

START HERE

Configure Data Logging Settings

Step 1

Enter the Brightness Mode

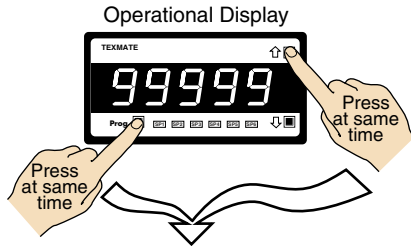

Step 2

Pass the Brightness mode, enter the Calibration Mode

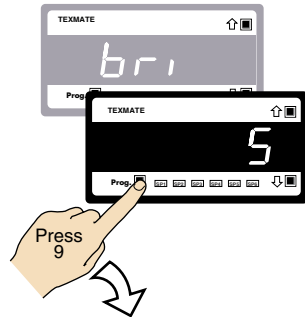

Step 3

Set the data logging settings

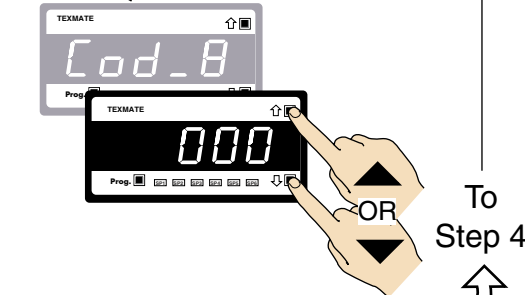

Example

Select the following data logging settings. Set Code 8 to [151]:
 1st Digit = 1 Cyclic Buffer
 2nd Digit = 5 Spreadsheet format – Time Stamp Format 1
 3rd Digit = 1 Selects Trigger ON DEMAND from PROGRAM button.

From Step 3

Step 4

Save Code 8 settings



Step 5

Exit Code 9 and return to the Operational Display

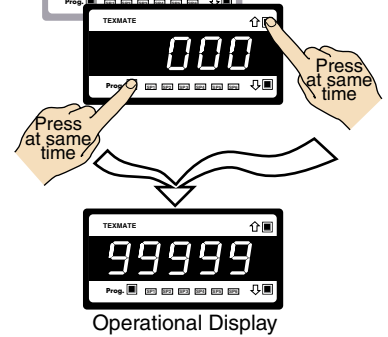

Terminal Program Configuration & Use Procedures

The following procedures describe how to set the Microsoft HyperTerminal properties, as well as using HyperTerminal to write to and read from the meter:

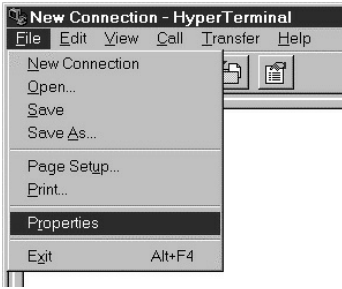

STEP A Set the HyperTerminal Program Properties

- 1) Start the Microsoft HyperTerminal program on the PC.
- 2) On the **File** menu, click **Properties**.

The **New Connection Properties** dialog box opens.

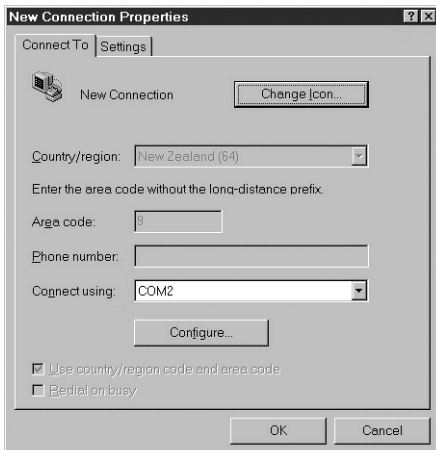

- 3) In the **Connect To** dialog click the arrow on the **Connect using** window and click a COM port (usually COM2).
- 4) Click the **Configure** button.

The **COM2 Properties** dialog opens.

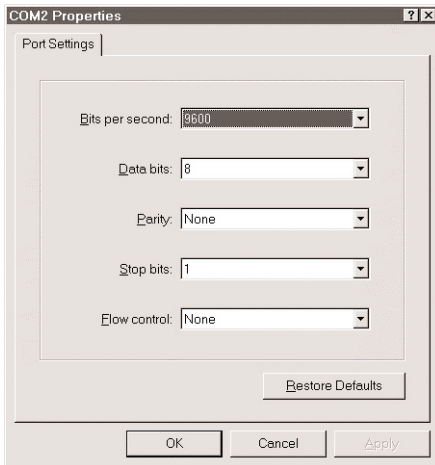

- 5) In the **Port Settings** dialog click the arrow on the **Bits per second** window and click 9600.
- 6) Click the arrow on the **Data bits** window and click 8.
- 7) Click the arrow on the **Parity** window and click **None**.
- 8) Click the arrow on the **Stop bits** window and click 1.
- 9) Click the arrow on the **Flow control** window and click **None**.
- 10) Click OK.

The **HyperTerminal Properties** dialog appears.

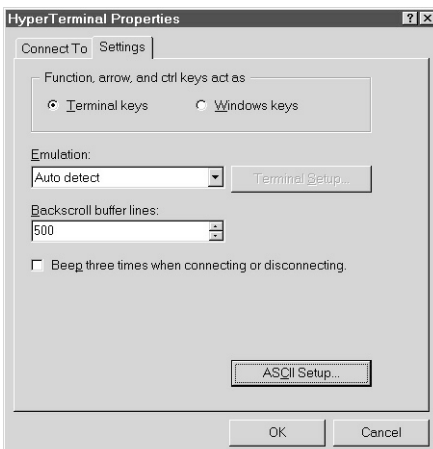

- 11) Click the **Settings** tab.
- 12) In the **Emulation** list box, click **Auto detect**.

The other settings are not relevant to this procedure and can be left as they are.

- 13) Click on the **ASCII Setup** button.

The **ASCII Setup** dialog opens.

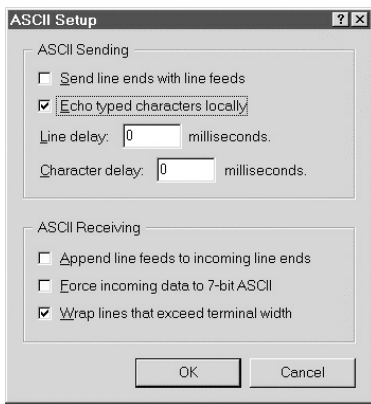

- 14) In the **ASCII Sending** group box, click the **Echo typed characters locally** check box.

The other settings are not relevant to this procedure and can be left as they are.

- 15) In the ASCII receiving group box, make sure the **Append line feeds to incoming line ends** check box is **not** checked.
- 16) Click OK.

The **ASCII Setup** dialog closes.

- 17) Click OK on the **New Connection Properties** dialog.

The **New Connection Properties** dialog closes.

STEP B Check Communications Between the Meter and the PC

- 1) Type the following in the terminal program: **SR***

The current meter reading is displayed on the PC screen.

STEP C Configure the Print String by Writing to Register X

- 1) Set the print string by selecting the register data to be downloaded by writing to register X. For example, to set the print string to download the current display value (from display register 2) and peak value (from peak register 12), type the following:

SWX ~2 ~12* (the spaces must be included).

This means that the data from the meter will display on the PC screen when the PRINT trigger is activated.

STEP D Set the Meter to the PRINT Mode

- 1) Set Code 3 to [XX3] in the meter's main programming mode.

This allows the meter to send the measurement data to the PC.

STEP E Download the Data from the Meter to the PC

- 1) Type the following in the terminal program: **P**

The P requests the meter to download the configured print string.

STEP F Capture the Meter Measurement Data on the PC

- 1) On the **Transfer** menu, click **Capture Text**.

The **Capture Text** dialog opens.

- 2) In the **File** window, type the destination for the capture text file, or click the **Browse** button and select the destination.

- 3) Name the file with **.txt** file extension, or leave it as CAPTURE.TXT.

- 4) Click the **Start** button.

This opens the file.

- 5) Type the following in the terminal program: **SR727***

The data saves to a text file in the destination you selected. It can be opened and printed, or loaded into a word processing or spreadsheet program for further processing.

- 6) When the download is complete, on the **Transfer** menu, click the **Capture Text** menu, and then click **Stop**.

- 7) When the data logging operation is complete, exit the HyperTerminal program.

STEP G To Open the Captured Text in Microsoft Excel

- 1) Open Microsoft Excel.
- 2) Select **Open** in the **File** menu.

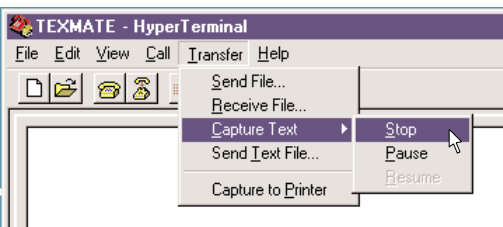
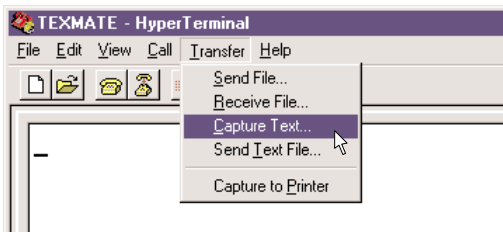

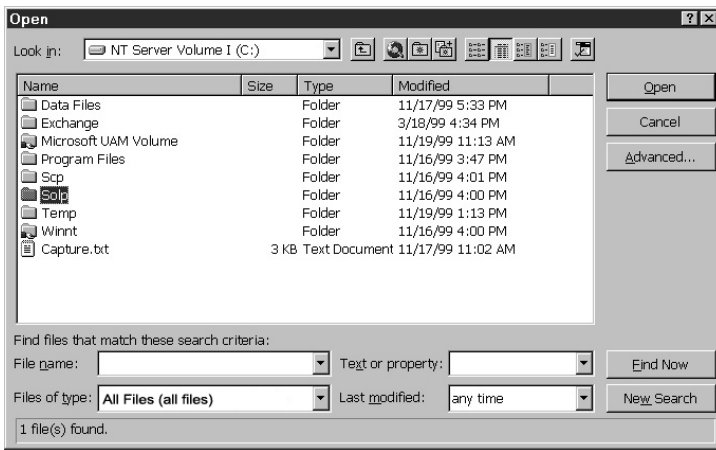

The **Open** dialog opens.



Note:

When loading the text file into a spreadsheet like MS Excel, it should be opened as a **space delimited file**.

- 3) In the **Open** dialog, click on the arrow in the **Files of type** window and select the **All Files (all files)** file type.
- 4) Find your captured text file and click the **Open** button.

The **Text Import Wizard – Step 1 of 3** dialog opens.

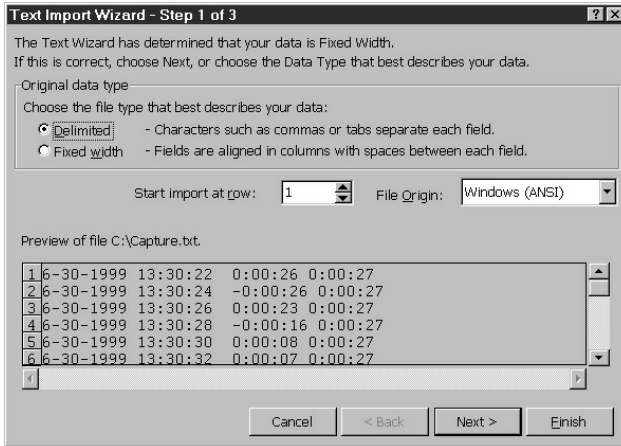

- 5) Click the **Delimited** radio button in the **Original data type** section.
- 6) Select the row you wish to start from in the **Start import at row** window.
- 7) Click the **Next** button.

The **Text Import Wizard – Step 2 of 3** dialog opens.

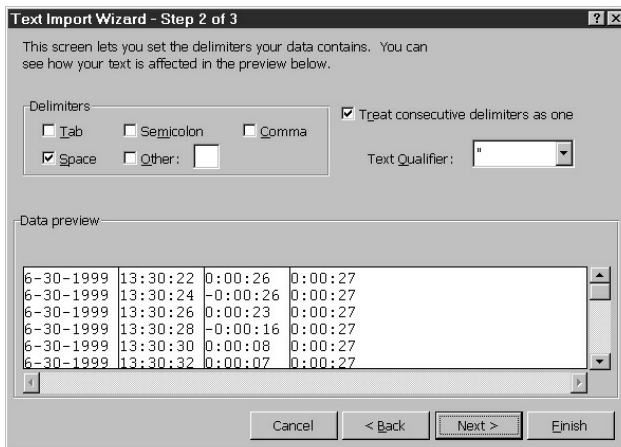

- 8) Check the **Space** check box in the **Delimiters** section.
- 9) Check the **Treat consecutive delimiters as one** check box.

- 10) Click the **Finish** button.

Excel will import your data and display it in four columns:

Column A: Date.

Column B: Time.

Column C: Register #2 – Rate.

Column D: Register #12 – Total.

You can now use your text file data to compile graphs, etc.

Figure 23 is an example of a graph constructed from captured text in Microsoft Excel.

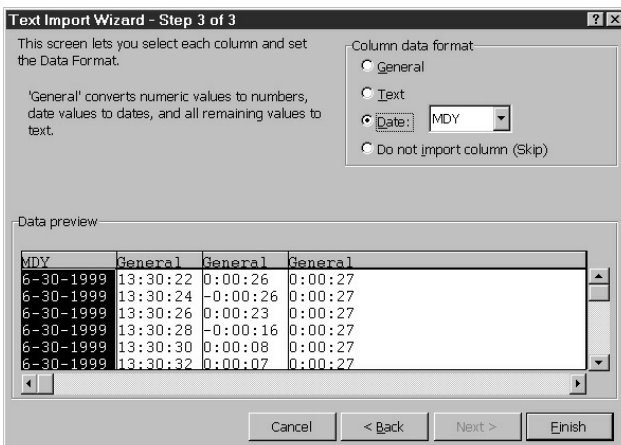

Note:

If you want, you can also set the format of the data in the columns in **Text Import Wizard – Step 3 of 3**.

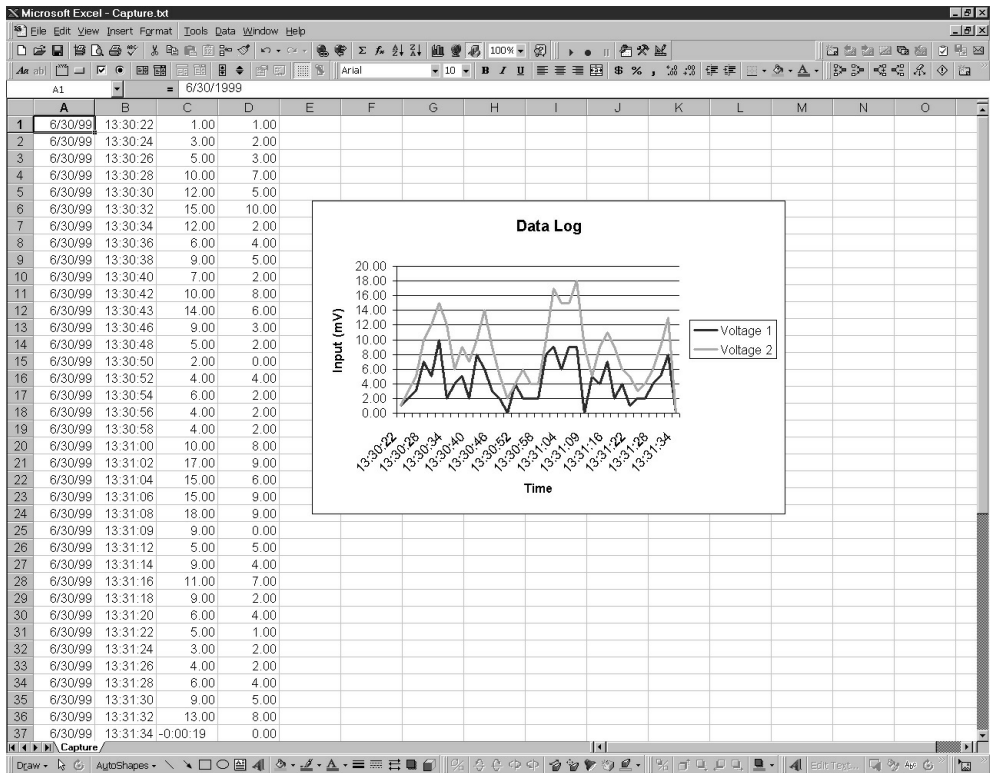

Figure 23 – Example Graph in Microsoft Excel

Automatic Trigger Source Configuration Procedures

The following procedures describe how to configure the meter to data log automatically from a setpoint. The procedure is written using setpoint 1 as the trigger, but any available setpoint can be used. The following example settings have been used:

- Setpoint Activation Value: 10 000 counts.
- Setpoint Activation Source: Display Register [diSP].
- Timer Mode: Normal [norM].
- Delay-on-make (DOM) Setting: 1 second [1.0].
- Delay-on-break (DOB) Setting: 1 second [1.0].
- Trigger Operating Edge: Level [LEvEL].



See *Setpoints & Relays Supplement* for full details on trigger modes and settings.

Select Source for Setpoint Functions

P
SourC
off

Use the ↑ ↓ buttons to cycle through the options

[diSP]
↑
↓
[rESLt]
↑
↓
[Ch1]
↑
↓
[Ch2]
↑
↓
[Ch3]
↑
↓
[Ch4]
↑
↓
[tot_1]

Use the ↑ ↓ buttons to select register as data source for selected setpoint.

START HERE

Configure Automatic Trigger Source

Step 1

Enter the Setpoint Programming Mode

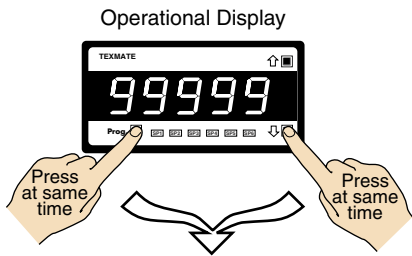

Setpoint Activation Values Mode

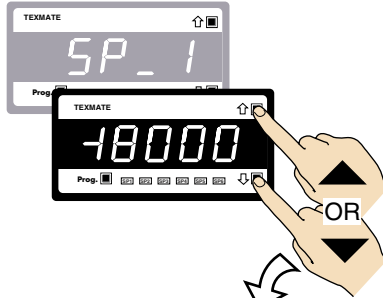

Step 2

Adjust the setpoint to the required activation value

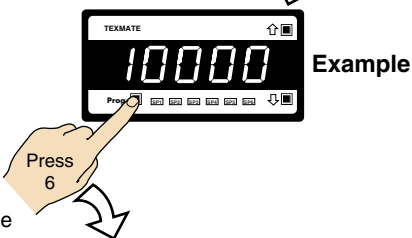

Step 3

Save the settings and enter the Setpoint & Relays Control Settings Mode

Setpoint & Relay Control Settings Mode

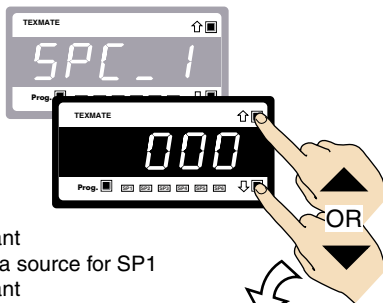

Step 4

Set SPC_1 to [X1X]:
1st Digit = X Not relevant
2nd Digit = 1 Select data source for SP1
3rd Digit = X Not relevant

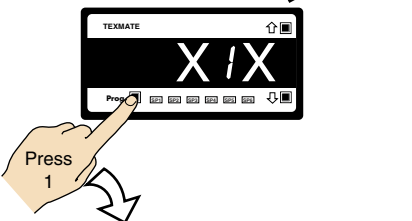

Step 5

Enter the Setpoint Activation Source Menu

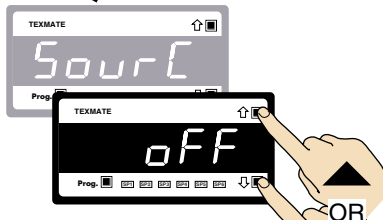

Step 6

Select a register as the activation source for SP1. See **Select Source for Setpoint Functions** diagram on Page 47

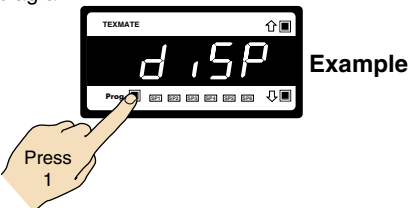

Step 7

Save SP1 activation source setting



From Step 7

Step 8

Enter the Timer Mode. Set SPC_1 to [XX6]:
1st Digit = X Not relevant to TIMER mode
2nd Digit = X Not relevant to TIMER mode
3rd Digit = 6 Selects TIMER mode

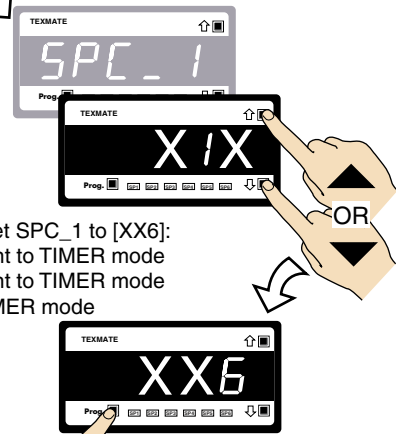

Step 9

Enter the Timer Mode

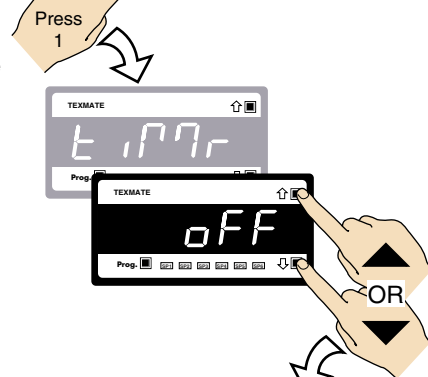

Step 10

Select a Timer Mode

TIMER Modes:

- Normal
- 1-Shot ON
- Pulse ON
- Repeat ON
- 1-Shot OFF
- Pulse OFF
- Repeat OFF

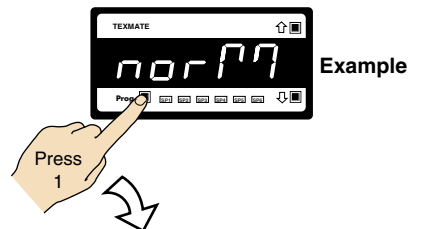

Step 11

Enter Timer Mode settings menu

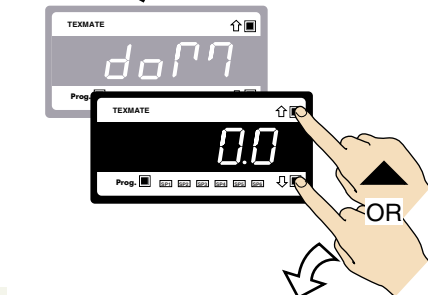

Step 12

Set delay-on-make (DOM) to 1 sec

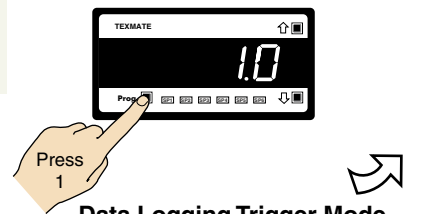

Programming Tip
The TIMER resolution is 0.1 seconds

Step 13

Save SP1 DOM setting

Data Logging Trigger Mode Configuration Procedure continued on next page



To Step 8



Data Logging Trigger Configuration Procedure
continued from bottom of previous page

Step 14
Set delay-on-break (DOB) to 1 sec

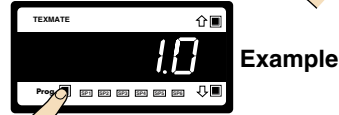
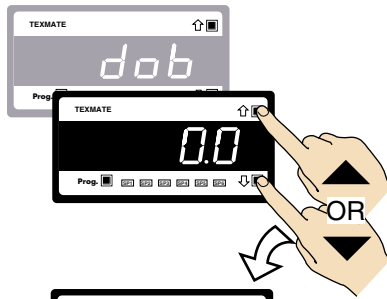

Step 15
Save DOB setting

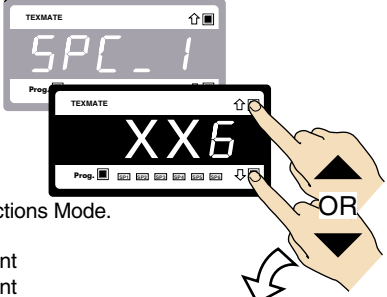

Step 16
Enter the Advanced Functions Mode.
Set SPC_1 to [XX7]:
1st Digit = X Not relevant
2nd Digit = X Not relevant
3rd Digit = 7 Selects Advanced Functions Mode

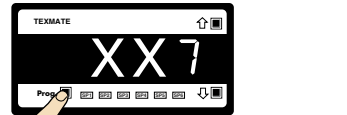

Step 17
Enter the Advanced Functions Mode

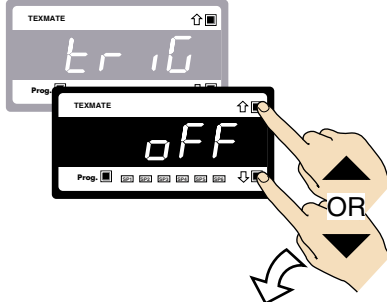

Step 18
Select which edge of the relay operation the trigger will activate on

- Relay Operation Edge:
- Make
 - Break
 - Both
 - Level



Step 19
Save the setting

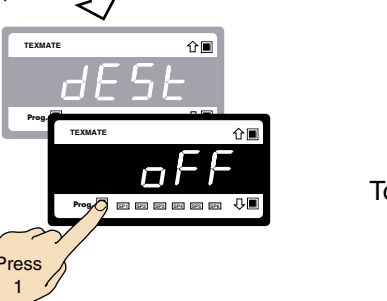

Step 20
Pass thru the Reset Destination Register Mode



From Step 20



Step 21
Pass thru the Printer Trigger Mode and enter the Log Trigger Mode

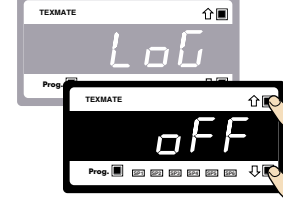
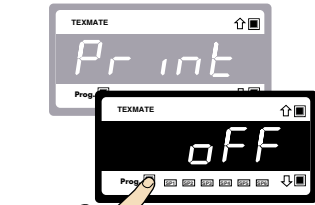

Step 22
Set Log Trigger to ON to activate the Log Trigger Mode



Example

Step 23
Save the Log Trigger settings

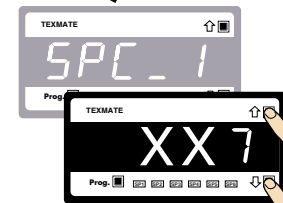

Step 24
Reset SPC_1 to [XX0]



Step 25



Step 25
Exit SPC_2 and return to the operational display



To Step 21

This page intentionally left blank

This page intentionally left blank

WARRANTY

Texmate warrants that its products are free from defects in material and workmanship under normal use and service for a period of one year from date of shipment. Texmate's obligations under this warranty are limited to replacement or repair, at its option, at its factory, of any of the products which shall, within the applicable period after shipment, be returned to Texmate's facility, transportation charges pre-paid, and which are, after examination, disclosed to the satisfaction of Texmate to be thus defective. The warranty shall not apply to any equipment which shall have been repaired or altered, except by Texmate, or which shall have been subjected to misuse, negligence, or accident. In no case shall Texmate's liability exceed the original purchase price. The aforementioned provisions do not extend the original warranty period of any product which has been either repaired or replaced by Texmate.

USER'S RESPONSIBILITY

We are pleased to offer suggestions on the use of our various products either by way of printed matter or through direct contact with our sales/application engineering staff. However, since we have no control over the use of our products once they are shipped, NO WARRANTY WHETHER OF MERCHANTABILITY, FITNESS FOR PURPOSE, OR OTHERWISE is made beyond the repair, replacement, or refund of purchase price at the sole discretion of Texmate. Users shall determine the suitability of the product for the intended application before using, and the users assume all risk and liability whatsoever in connection therewith, regardless of any of our suggestions or statements as to application or construction. In no event shall Texmate's liability, in law or otherwise, be in excess of the purchase price of the product.

Texmate cannot assume responsibility for any circuitry described. No circuit patent or software licenses are implied. Texmate reserves the right to change circuitry, operating software, specifications, and prices without notice at any time.



995 Park Center Drive • Vista, CA 92081-8397

Tel: 1-760-598-9899 • USA 1-800-839-6283 • That's 1-800-TEXMATE

Fax: 1-760-598-9828 • Email: sales@texmate.com • Web: www.texmate.com

Texmate has facilities in Japan, New Zealand, Taiwan, and Thailand. We also have authorized distributors throughout the USA and in 28 other countries.

For product details visit www.texmate.com

Local Distributor Address