



TM-35XJC, TM-35XJF, TM-35XKC & TM-35XKF

Panel Temperature Meters
3 1/2 Digit 0.48" LCD
in a Slim Bezel Case



A low cost LCD temperature meter for 'J' or 'K' thermocouples, °C or °F, 5V DC powered with screw terminal or edge connector inputs.

General Features

Texmate's popular TM-35 Series of 5V DC powered temperature meters are available with an LED or LCD display.

The meters are supplied factory-configured either for 'J' or 'K' thermocouples, and scaled for °C or °F. On site re-scaling for °C or °F is possible. A selectable °C/°F descriptor is included with every meter. The unique differential input configuration facilitates operation with both grounded and ungrounded probes and allows several meters, operating with grounded thermocouples, to be powered by the same non-isolated 5VDC supply.

The standard meter is provided with TB-KIT screw terminal blocks and insulated quick-disconnects. For the greatest convenience and ease of use, order the optional preconfigured Push-On screw terminal connectors. (see Push-On Screw Terminals and Ordering Information on pages 3 & 4)

Typical Application Connections

Single-Ended Input

For optimum noise reduction, either the + or - lead of the thermocouple should be connected to power supply ground.

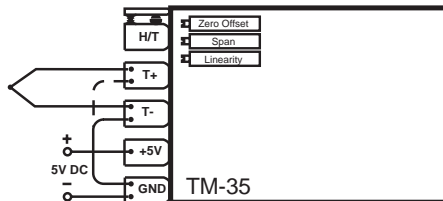

Differential Input with Grounded Thermocouples

The unique differential input of the TM-35 Series enables the use of grounded thermocouples by several meters powered from the same 5V DC supply.

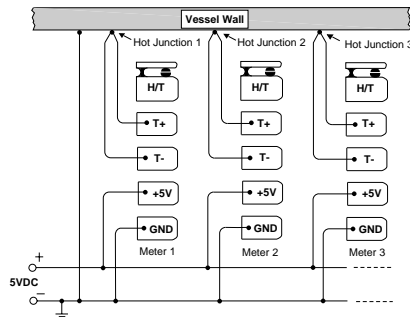

For additional connection information see page 3.

Compatibility

The TM-Series is shipped in a standard Slim Bezel case. The Slim Bezel case is compatible with the CM, SM, PM, & SP Series of meters. The TM-Series can be ordered in End Mount cases for twin mounting or combinations of multiple center mount cases and two end mount cases for stack mounting.

SLIM



BEZEL

Specifications

Input Configuration:.....True differential and single-ended.

Thermocouple Ranges:.....0 to 760°C 'J' Thermocouple
0 to 1400°F

0 to 1260°C 'K' Thermocouple
0 to 1999°F

(consult factory for other types)

Resistance Effect:20µV per 10Ω of lead resistance.

Compensation (RJC):Automatic, ±0.1°C/°C

Input Protection:25V AC/DC

Normal Mode Rejection: ..>40dB above 50Hz

Common Mode Rejection:...±4V referred to power supply ground.

Conformity Error:.....±(2°C + 1 Digit) typical

±(4°C + 1 Digit) maximum

±(3°F + 1 Digit) typical

±(5°F + 1 Digit) maximum

Resolution:1°C or 1°F

Warm-up Time:One minute to specified accuracy.

Conversion Rate:3 readings per second

Display:0.48" Liquid Crystal Display (LCD)

"Display Hold" & °C/°F descriptor.

Over-range Indication:.....Most significant "1" digit and polarity symbol are displayed with all other digits blank.

Power Supply:+4.75 to +5.25V DC at 40mA

Operating Temperature:.....-20°C to +50°C

Storage Temperature:-20°C to +70°C

Relative Humidity:95% (non-condensing)

Case Dimensions:Bezel 2.76" X 1.17" (69.75 X 29.7mm)

Depth behind Bezel 3.32" (84mm) plus

0.68" (17.27mm) for connector

Weight:156 gms (5.5 oz) when packed

TM-35 Series LED Displays

TM-35JC3.5 digit LED-Type J °C Thermocouple, 5VDC Pwr

TM-35JF3.5 digit LED-Type J °F Thermocouple, 5VDC Pwr

TM-35KC3.5 digit LED-Type K °C Thermocouple, 5VDC Pwr

TM-35KF3.5 digit LED-Type K °F Thermocouple, 5VDC Pwr

TM-35 Series LCD Displays

TM-35XJC3.5 digit LCD-Type J °C Thermocouple, 5VDC Pwr

TM-35XJF3.5 digit LCD-Type J °F Thermocouple, 5VDC Pwr

TM-35XKC3.5 digit LCD-Type K °C Thermocouple, 5VDC Pwr

TM-35XKF3.5 digit LCD-Type K °F Thermocouple, 5VDC Pwr

Functional Diagram

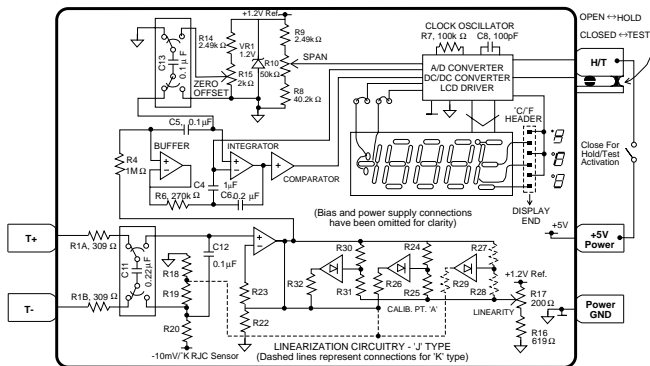

Connector Pinouts

The Texmate TM-35X interconnects using the screw terminal blocks supplied with the meter. Alternatively a standard PC board edge connector may be used, having two rows of 10 pins each, spaced on 0.156" centers. Connectors are available from Texmate or from almost any connector manufacturer.

CAUTION: This meter employs high impedance CMOS inputs. Although internal protection has been provided for several hundred volt overloads, the meter will be destroyed if subjected to the high kilovolts of static discharge that can be produced in low humidity environments. Always handle the meter with ground protection.

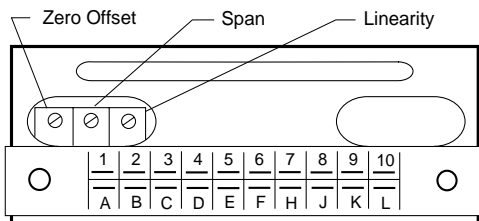

METER REAR WITH PCB EDGE CONNECTOR MOUNTED

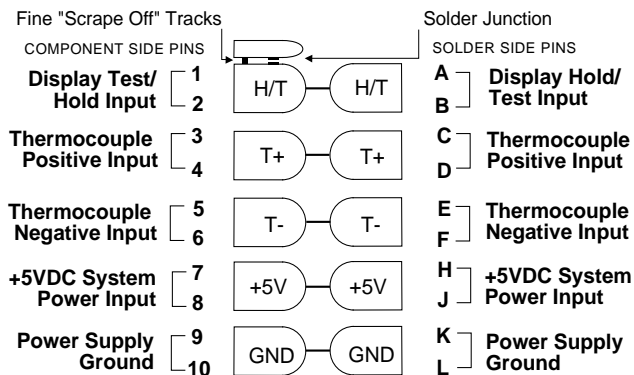

Pins (A,B) & (1,2) - Display Test/Display Hold Input: All numeric display segments will operate when Pins (A,B) & (1,2) are connected to +5VDC System Power Input Pins (H,J) & (7,8).

CAUTION: This Display Test function is only intended for momentary operation. Continuous operation of Display Test will in time damage the display.

The function of this input may be re-configured to operate as Display Hold by scraping off the fine track adjacent to Pin 1 (re-bridge, if required, at the solder junction). To initiate Display Hold, connect Pins (A,B) & (1,2) to +5VDC Power Supply Input Pins (H,J) & (7,8) and the meter will latch up; A/D conversions will continue but the display will not be updated until Pins (A,B) & (1,2) are released.

Pins (C,D) & (3,4) - Thermocouple Positive Input: The thermocouple positive output is applied to these pins (refer to Table 2 for color codes). Maximum overvoltage protection is 25V AC/DC.

Pins (E,F) & (5,6) - Thermocouple Negative Input: The thermocouple negative output is applied to these pins (refer to Table 2 for color codes). Maximum overvoltage protection is 25V AC/DC.

Pins (H,J) & (7,8) - +5VDC System Power Input: The meter requires a regulated low-ripple 5VDC power supply applied to these pins.

Pins (K,L) & (9,10) - Power Supply Ground: Power supply ground return.

Component Layout

'J' Thermocouple Shown Below

Additional Components for 'K' Thermocouple Are Shown Shaded

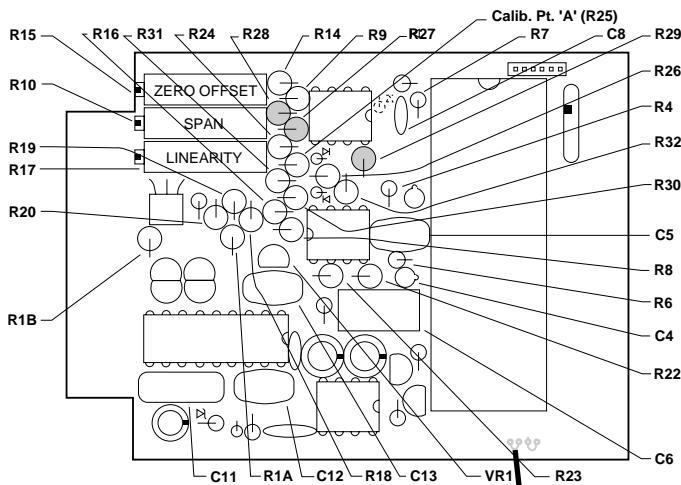

Cut to disable "+" polarity indication

Signal Conditioning Components

ZERO ZERO Potentiometer (Pot)

To the Left Front The ZERO pot is on the left (as viewed from the back of the meter). Typically it enables the input signal to be offset $\pm 5\%$ of full scale. Turn Clockwise to Increase Reading

SPAN SPAN Potentiometer (Pot)

To the Right Front The 15 turn SPAN pot is middle pot (as viewed from the back of the meter). Typical adjustment is 20% of the input signal range. Turn Clockwise to Increase Reading

LINEARITY Linearity Potentiometer (Pot)

To the Right Front The Linearity pot is used to set the voltage at the calibration Point "A" and is located on the right (as viewed from the back of the meter). Use to set voltage at Calibration Point "A" The Linearity Pot is adjusted at the factory and does not normally need to be re-adjusted by the user.

Polarity Display Header

This header allows the Polarity indication to be displayed normally, displayed reversed or to be disabled completely.

Calibration Instructions

POINTS TO NOTE

The TM-35X has been factory calibrated for optimum performance and should not normally require further calibration or adjustment. If the need for on-site re-calibration is determined, follow the procedure below and verify that the voltage and meter display are incorrect before disturbing potentiometer settings.

Note: The potentiometer settings are sealed at the factory. Any user modification of these settings may, at the discretion of Texmate, void the warranty.

Re-calibration requires either a thermocouple simulator or a precision

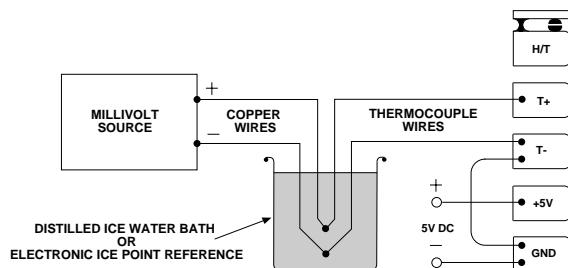

Calibration Instructions Continued

millivolt source, thermocouple reference junction, and an ice point reference. A digital voltmeter is also required. The calibration arrangement used should completely simulate normal thermocouple connections to the meter. The drawing below illustrates the connection details when using a millivolt source and an ice point reference.

Before calibration, determine the values for linearity, zero offset, and span adjustment from the table. As an example, the values appropriate for a TM-35XJC ('J' thermocouple, °C scaling) are: 760° (linearity), 0° (zero offset), and 760° (span). Having determined these values, follow the steps described below:

NOTE: For re-scaling between °C/°F, linearity re-calibrated (Step 1) may be omitted.

1. Calibrate the LINEARITY

Apply the linearity calibration voltage to the TM-35X. Connect the voltmeter to calibration point 'A' (shown on the component layout). Adjust the LINEARITY potentiometer (R17) until the voltage at point 'A' is exactly 1.000V.

2. Calibrate the ZERO OFFSET

Apply the zero offset calibration voltage to the TM-35X. Adjust the zero offset potentiometer (R15) to make the meter display zero. The optimal setting is achieved when the polarity sign alternates between '+' and '-'.

3. Check the Calibration

Apply the span calibration voltage to the TM-35X. Adjust the span potentiometer (R10) until the meter display matches the value shown in table one.

4. Program the °C/°F Descriptor

Refer to the "Descriptor Re-Programming" procedure below. This should only be necessary if the meter is re-scaled between °C and °F.

CALIBRATION

Separate potentiometers are provided for adjustment of linearity, zero offset, and span. Calibration involves the application of various voltages representing temperatures according to the thermocouple type and meter scaling. These values are summarized in the table below in terms of temperature and equivalent thermocouple voltage output.

		'J' Type		'K' Type	
		°C	°F	°C	°F
Linearity (R17) <i>Calib. Pt. 'A' = 1.000V</i>	T/C Simulator	760	1400	1260	2300
	Millivolt Source	42.922mV	42.922mV	50.990mV	50.990mV
Zero Offset (R15) <i>Zero Adjustment</i>	T/C Simulator	0	0	0	0
	Millivolt Source	0.000mV	-0.885mV	0.000mV	-0.701mV
Span (R10) <i>Full Scale Adjustment</i>	T/C Simulator	760	1400	1260	1990
	Millivolt Source	42.922mV	42.922mV	50.990mV	44.645mV

Differential-Input Meter

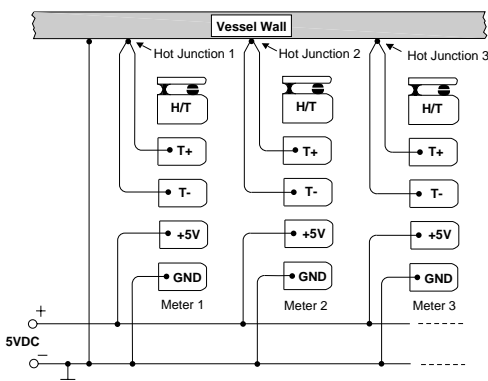

The differential input feature of the TM-35X facilitates temperature measurement using grounded thermocouples. In this configuration, an indirect ground return path is still required to prevent the common mode range of the inputs from being exceeded, but the circuit differs from the single-ended configuration in that the power supply ground is connected to the thermocouple junction common point, rather than to the thermocouple positive or negative input on the meter. This avoids the introduction of circulating currents in the thermocouple wires arising from ground loops, which may otherwise result in erroneous or noisy readings. Several meters may be cascaded in this configuration all powered by the same 5V DC supply, as shown above.

Thermocouple Color Codes

		GB BRITAIN BS 1843	F FRANCE NF C42-323	D GERMANY DIN 43714	USA U.S.A. ANSI/ MC964	JPN JAPAN JIS C 1610- 1981
'J'	Positive	Yellow	Yellow	Red	White	Red
	Negative	Blue	Black	Blue	Red	White Yellow Sheath
'K'	Positive	Brown	Yellow	Red	Yellow	Red
	Negative	Blue	Purple	Green	Red	White Blue Sheath

Single-Ended Meter

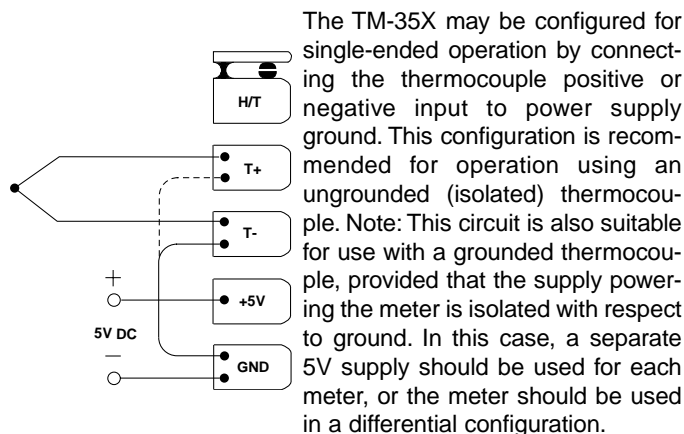

The TM-35X may be configured for single-ended operation by connecting the thermocouple positive or negative input to power supply ground. This configuration is recommended for operation using an ungrounded (isolated) thermocouple. Note: This circuit is also suitable for use with a grounded thermocouple, provided that the supply powering the meter is isolated with respect to ground. In this case, a separate 5V supply should be used for each meter, or the meter should be used in a differential configuration.

TB-Kit Screw Connectors

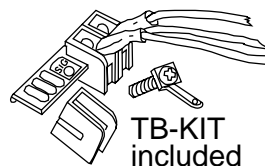

TB-KIT
included

Texmate's individual screw terminal blocks offer a convenient alternative to edge connectors for many applications, allowing complete installation, configuration and calibration without the need for soldering.

Slide each terminal block over the PCB until the hole aligns. Insert the retaining screw to secure. Each kit includes: 3 plastic blocks with metal contacts, 4 screws with spade connectors, 1 metal contact and 3 quick disconnects.

Push-On Screw Terminals

They provide the greatest convenience and ease of use

Texmate's exclusive optional Push-On Connectors combine an edge card connector and a 10 position screw terminal block. Push-On Connectors are ordered preconfigured for each specific power supply voltage and each optional power supply available for the TM-Series.



Part Number: CN-PUSH/TM

TM Case Dimensions and Panel Cutouts

The Slim Bezel Case is supplied as standard. If specified at time of ordering, any combination of Twin Mounting and Multiple Array Cases may be substituted at no additional cost. Extra cases may be ordered separately.

STANDARD SLIM BEZEL CASE

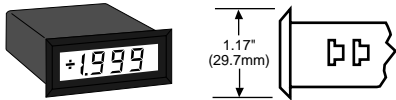

SLIM BEZEL CASE
Standard Black ABS case with matte finish bezel for single unit mounting.

Part No. **SL-CASERED** for LED's
SL-CASECLR for LCD's

OPTIONAL TWIN MOUNTING OR MULTIPLE ARRAY CASES

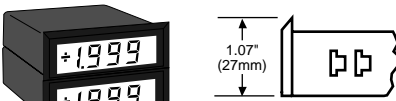

END MOUNT CASE
Same styling as Slim Bezel case but with bottom edge of bezel removed. Two End Mount cases can be twin mounted in a single cutout.

Part No. **EM-CASERED** for LED's
EM-CASECLR for LCD's



CENTER MOUNT CASE
Any number of Center Mount cases may be fitted between two End Mount cases for multiple arrays.

Part No. **CM-CASERED** for LED's
CM-CASECLR for LCD's

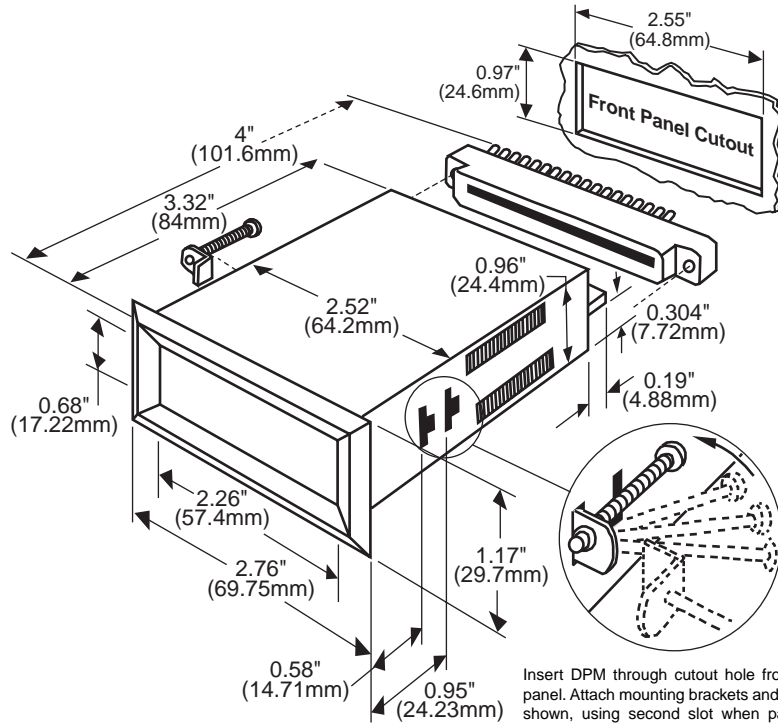

Insert DPM through cutout hole from front of panel. Attach mounting brackets and screws as shown, using second slot when panel thickness is greater than 1/4 inch. Tighten screws against rear of panel.

Optional PCB Edge Connector

PCB Edge Connector

A standard 20-pin edge connector (two rows of 10 pins on 0.156" centers) is used to connect all TM-35X meters. Order part no. CN-L10.

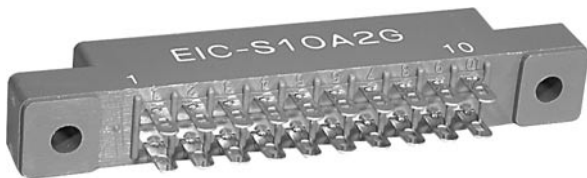

Ordering Information

Standard Options for this Model Number

Part Number	Description	List
► BASIC MODEL NUMBER Includes plug in type screw terminals, standard display and standard power supply.		
TM-35XJC	3.5 digit LCD-Type J °C Thermocouple, 5VDC Pwr	\$104
TM-35XJF	3.5 digit LCD-Type J °F Thermocouple, 5VDC Pwr	\$104
TM-35XKC	3.5 digit LCD-Type K °C Thermocouple, 5VDC Pwr	\$104
TM-35XKF	3.5 digit LCD-Type K °F Thermocouple, 5VDC Pwr	\$104

Special Options and Accessories

Part Number	Description	List
► ACCESSORIES		
CN-L10	Edge Connector with Solder eyelet, 10 Pin Dual	\$3
TB-KIT	Replacement Terminal Block Connector Kit (3)	\$1
SL.CASECLR	Slim Bezel Case, Clear Faceplate w/Mtg Hrdwre	\$6
CM.CASECLR	Cr. Mount Case, Clear Faceplate w/Mtg Hrdwre	\$6.50
EM.CASECLR	End Mount Case, Clear Faceplate w/Mtg Hrdwre	\$6.50

Prices subject to change without notice.

WARRANTY

Texmate warrants that its products are free from defects in material and workmanship under normal use and service for a period of one year from date of shipment. Texmate's obligations under this warranty are limited to replacement or repair, at its option, at its factory, of any of the products which shall, within the applicable period after shipment, be returned to Texmate's facility, transportation charges pre-paid, and which are, after examination, disclosed to the satisfaction of Texmate to be thus defective. The warranty shall not apply to any equipment which shall have been repaired or altered, except by Texmate, or which shall have been subjected to misuse, negligence, or accident. In no case shall Texmate's liability exceed the original purchase price. The aforementioned provisions do not extend the original warranty period of any product which has been either repaired or replaced by Texmate.

USER'S RESPONSIBILITY

We are pleased to offer suggestions on the use of our various products either by way of printed matter or through direct contact with our sales/application engineering staff. However, since we have no control over the use of our products once they are shipped, NO WARRANTY WHETHER OF MERCHANTABILITY, FITNESS FOR PURPOSE, OR OTHERWISE is made beyond the repair, replacement, or refund of purchase price at the sole discretion of Texmate. Users shall determine the suitability of the product for the intended application before using, and the users assume all risk and liability whatsoever in connection therewith, regardless of any of our suggestions or statements as to application or construction. In no event shall Texmate's liability, in law or otherwise, be in excess of the purchase price of the product.

Texmate cannot assume responsibility for any circuitry described. No circuit patent or software licenses are implied. Texmate reserves the right to change circuitry, operating software, specifications, and prices without notice at any time.

TEXMATE INC

995 Park Center Drive • Vista, CA 92081-8397

Tel: 1-760-598-9899 • USA 1-800-839-6283 • That's 1-800-TEXMATE

Fax: 1-760-598-9828 • Email: sales@texmate.com • Web: www.texmate.com

Texmate has facilities in Japan, New Zealand, Taiwan, and Thailand. We also have authorized distributors throughout the USA and in 28 other countries.

For product details visit www.texmate.com

Local Distributor Address

Copyright © 2003 Texmate Inc. All Rights Reserved.