

## UM-35J & UM-35K

Thermocouple Temperature Meters  
3 1/2 Digit with 0.56" or 0.8" LEDs  
in a Traditional NEMA Style Case

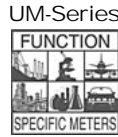

Low cost utility, J or K thermocouple temperature meters with 1° resolution pre-calibrated in °F or °C.

### General Features

The UM-35J and UM-35K are economical thermocouple input temperature meters with a resolution of 1°. The meters are ordered factory calibrated for either a °F or °C indication. Automatic cold junction compensation, Thermocouple Break Detection, Display Hold and Display Test functions are provided as standard features.

The standard meter is provided with TB-KIT screw terminal blocks and insulated quick-disconnects. For the greatest convenience and ease of use, order the optional preconfigured Push-On screw terminal connectors. (see Push-On Screw Terminals and Ordering Information)

### Typical Application Connections

#### Temperature Measurement with J Thermocouple

1°C or 1°F Resolution

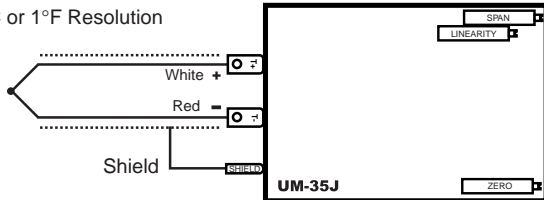

Grounded or Ungrounded thermocouples may be used.

#### Temperature Measurement with K Thermocouple

1°C or 1°F Resolution

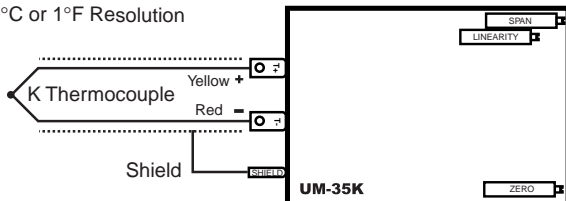

Grounded or Ungrounded thermocouples may be used.

### Compatibility

The UM-Series NEMA case style is complementary to Texmate's Classic RP-Series. For economy, each UM model is dedicated to a specific application. UMs are ideal for upgrading or replacing the traditional USA NEMA case panel meters presently in use.

Traditional  
**NEMA**  
STYLE USA  
**CASE**

### UM-Series low cost utility meters for switchboard and process indication

- UM-35AC11/5 AC amps, Scaled RMS, (1 or 5 Amp internal shunt), 3.5 digit
- UM-35AC .....AC volts, Scaled RMS. 199.9V AC/500V AC Header Selectable Ranges, 3.5 digit
- UM-40AC .....AC volts, Scaled RMS. 500.0V AC full scale, high resolution 4 digit
- UM-35HZ .....15Hz to 199.9Hz or optionally 40Hz to 500Hz up to 500V AC input, 3.5 digit
- UM-35 .....DC Volts ±2/20V DC Header selectable or optionally ±2/200V DC, 3.5 digit
- UM-35MV .....DC mV ±50mV and ±100mV select inputs to suit DC current shunts, 3.5 digit
- UM-45 .....DC Volts ±2V/±20V/±200V DC Header selectable ranges 4.5 digit
- UM-45MV .....DC mV ±50 mV, ±100mV, or ±200mV selectable inputs to suit DC current shunts, 4.5 digit

### Specifications

- Input Configuration: .....Differential
- Full Scale Ranges:.....UM-35JC 0 to 760°C  
UM-35JF 0 to 1400°F  
UM-35KC 0 to 1260°C  
UM-35KF 0 to 1999°F
- Lead Resistance Effects: ..20µV per 10Ω of lead resistance
- Cold Junction Compensation:.....Automatic ±0.1°C/°C (Cal. @25°C)
- Input Protection: .....25V AC/DC
- A/D Converter: .....12 Bit Dual Slope
- Conformity Error (at 25°C): .....UM-35JC ±(2°C + 1 digit) typical  
UM-35JF ±(4°F + 1 digit) maximum  
UM-35KC ±(3°C + 1 digit) typical  
UM-35KF ±(5°F + 1 digit) maximum

- Temperature Coefficient: ..100ppm/°C (Typical)
- Warm Up Time: .....Two minutes to specified accuracy
- Conversion Rate: .....3 readings per second
- Display: .....0.56" hi efficiency Red or optional Green LEDs. Display Hold & Display Test are provided.
- Polarity:.....Bipolar. Assumed positive, displays negative
- Overrange/ Open Thermocouple Indication: ..Most significant "1" digit is displayed with all other digits blank
- Power Supply (std): .....120/240V AC, 50/60/400 Hz. approx 1.5W.

- (Optn) VO-DC/ISO .....Isolated Switcher 9 to 36V DC/12 to 24V AC
- (Optn) VO-24V .....Isolated Transformer 24V AC ±10%
- (Optn) VO-5V DC .....Non-isolated 5V DC ±10%
- Operating Temperature: ..-10 to 50 °C
- Storage Temperature: .....-20 to 70 °C.
- Relative Humidity: .....95% (non condensing)
- Case Dimensions: .....Bezel 4.06"Wx1.89"H (102.7Wx47.9Hmm)  
Depth behind bezel 3.64" (92.22 mm) Plus 0.5 to .9" (12.7 to 22.8mm) depending on connector used.
- Weight:.....10 oz., 13 oz when packed.

## Functional Diagram

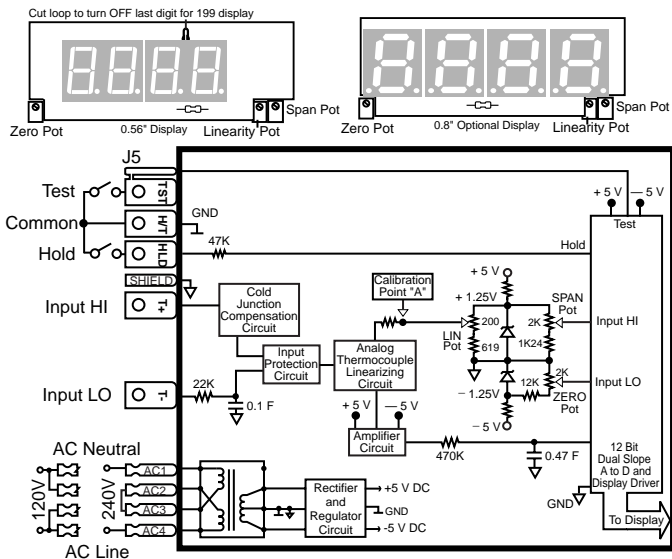

## Connector Pinouts

The UM-35JK can be connected, except for the shield Pins 5-E, using the TB-KIT screw terminal blocks provided with the meter. For greatest convenience, order a Push-On screw terminal connector that provides a shield output (see Push-On Screw Terminals). Alternatively, a pcb edge connector can be used. (see connector options)

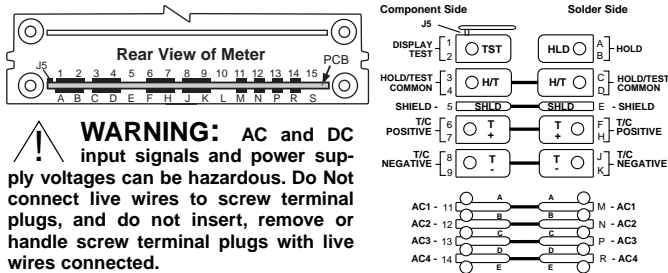

**WARNING:** AC and DC input signals and power supply voltages can be hazardous. Do Not connect live wires to screw terminal plugs, and do not insert, remove or handle screw terminal plugs with live wires connected.

**Pins 1 & 2 - Display Test:** All numeric display segments will light up when this pin is connected to the H/T Common Pin. A Texmate TB-KIT Screw Terminal Clip can be used to access the Display Test function.

**Pins 3, 4, C & D - H/T Common Pin:** The Hold and Display Test pins have to be connected to this pin to activate their respective functions.

**Pins A & B - Hold Reading:** When these pins are connected to the H/T Common pin, A/D conversions will continue, but the display will hold and not be updated until Pins A & B are disconnected. When using a Texmate TB-KIT Screw Terminal, J5 has to be opened to disconnect the Test function and enable the Hold function. If both hold and test functions need to be accessed, a Push-On Screw Terminal can be used.

**Pin 5 - Shield:** This pin is internally connected to the ground of the internal power supply.

**Pins 6, 7, F & H - Thermocouple Positive Input:** The thermocouple positive output is applied to these pins. Maximum overvoltage protection is 25V AC/DC.

**Pins 8, 9, J & K - Thermocouple Negative Input:** The thermocouple negative output is applied to these pins. Maximum overvoltage protection is 25V AC/DC.

**Pins 11 & M - AC1 - Live AC Power Input:**

**Pins 12 & N - AC2 - 110/220V AC Power Select:** See below for connections

**Pins 13 & P - AC3 - 110/220V AC Power Select:**

**Pins 14 & R - AC4 - Neutral AC Power Input:**

100 to 120V AC      200 to 240V AC & Optional 24V      Optional VO-DISO 9-26V DC/12-24V AC

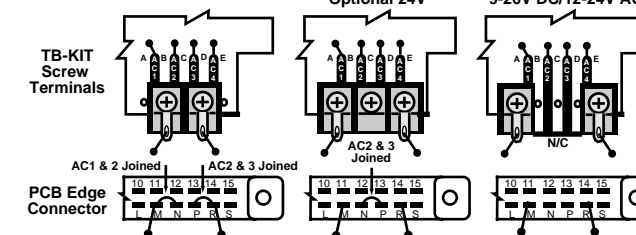

## Component Layout

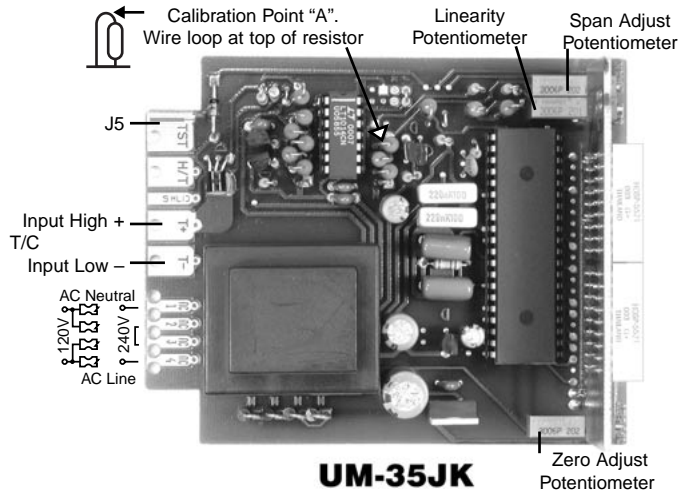

## Signal Conditioning Components

**SPAN** **SPAN Potentiometer (Pot)**  
To the Right Front The 15 turn SPAN pot is always on the right side (as viewed from the front of the meter). Typical adjustment is 20% of the input signal range.  
Turn Clockwise to Increase Reading

**ZERO** **ZERO Potentiometer (Pot)**  
To the Left Front The ZERO pot is to the left of the SPAN pot (as viewed from the front of the meter). Typically it enables the input signal to be offset  $\pm 5\%$  of full scale.  
Turn Clockwise to Increase Reading

**LINEARITY** **LINEARITY Potentiometer (Pot)**  
To the Right Front The Linearity pot is used to set the voltage at the calibration Point "A". The Linearity Pot is adjusted at the factory and does not normally need to be re-adjusted by the user.  
Use to set voltage at Calibration Point "A"

## Calibration Procedure

1. Connect a J or K Thermocouple Simulator to the input of the appropriate model and calibrate according to the Calibration Table. If your simulator does not output the specific values shown in the Table, then set the simulator to the next nearest value and make the calibration adjustments to that value instead of the values in the Table.
2. LINEARITY. The LINEARITY Pot is calibrated at the factory and does not normally need to be re-calibrated by the user. If Linearity must be re-calibrated, connect a voltmeter between the shield and calibration Point "A" (shown on the component layout), then follow step 3.

### Calibration Table

UM - model no.	UM-35JF	UM-35JC	UM-35KF	UM-35KC
<b>Thermocouple Type</b> Can not be changed	J	J	K	K
<b>Temperature Scale</b> Re-calibrate to change °F/°C	°F	°C	°F	°C
3. Adjust Linearity Pot until the voltage at calibration Point "A" is exactly 1.000V with the simulator output set to:	1400°F	760°C	1990°F	1260°F
4. Adjust Zero Pot so display matches TC simulator with output set to:	0°F	0°C	0°F	0°C
5. Adjust Span Pot so display matches TC simulator with output set to:	1400°F	760°C	1990°F	1260°F

6. The J meter is now calibrated and ready for use.

## TB-Kit Screw Connectors

Six Screw Terminals included Free with each UM Series meter

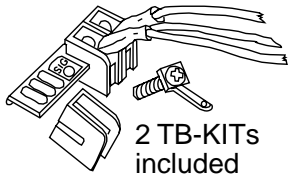

A TB-KIT consists of 3 insulated Quick Connects and 3 of Texmate's patented individual screw terminal blocks which attach directly to PCB inputs. These provide a Quick Connect tab and screw clamp termination. When using the TB-KIT screw terminal blocks, it is possible to

select between 120V AC and 240V AC power, the optional low voltage switching power supply or the 24V AC power supply by connecting the screw terminals as shown in the diagrams below.

## Optional PCB Edge Connector

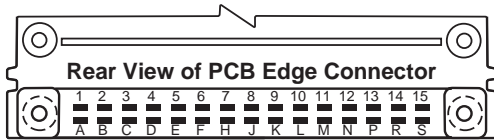

A standard 30 pin edge connector (two rows of 15 pins on 0.156" centers) may also be used to connect the UM-Series. Order part no. CN-L15. For different power supply voltage connection details, see pin connections below.

## Selecting Power Supply Voltages

With TB-KIT Screw Terminals

With Optional PCB Edge Connector

For 100 to 120V AC, 50/60 Hz

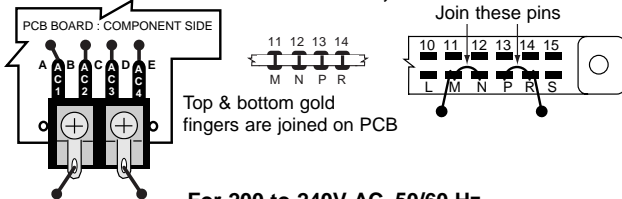

For 200 to 240V AC, 50/60 Hz  
or For Optional 24V AC (P.N.:V0-24V)

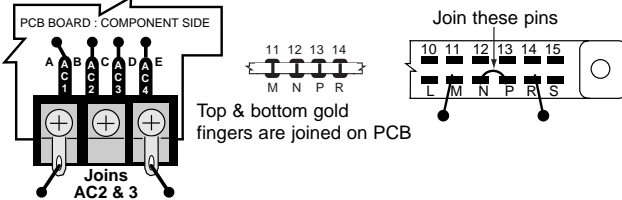

For Isolated 9-36V DC/12-24V AC, 50/60 Hz  
Switching Power Supply

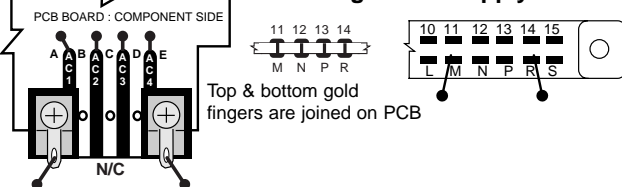

## Push-On Screw Terminals

They provide the greatest convenience and ease of use

Texmate's exclusive optional Push-On Connectors combine an edge card connector and a 10 position screw terminal block. Push-On Connectors are ordered preconfigured for each specific power supply voltage and each optional power supply available for the UM-Series.

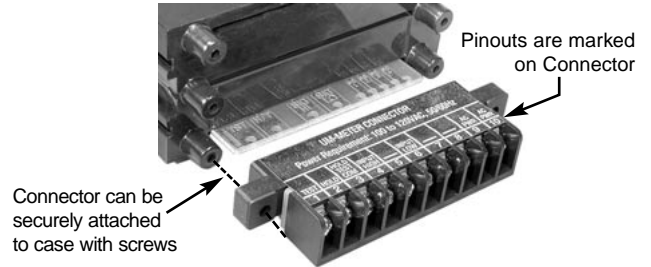

CN-PUSH/JK	.....	100/120V AC
CN-PUSH/JK01	.....	200/240V AC
CN-PUSH/JK03	.....	.24V AC
CN-PUSH/JK04	.....	.9-36V DC/12-24V AC
CN-PUSH/JK05	.....	.5V DC

## Pinout Change-Over Connectors

To replace DPMs in existing panels where matching pinouts are required, Texmate can provide custom pinout Change-over Connectors, either with PCB gold finger terminations, (shown below) or customized versions of Push-On Screw Terminals. (shown above)

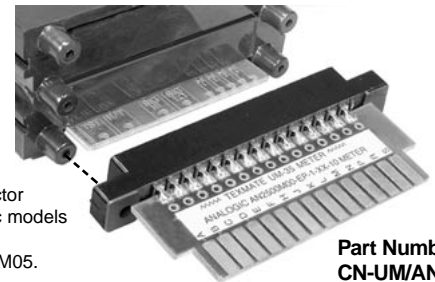

## Face Plate Descriptors

Volts AC	Volts DC	Hz	RPM
Amps AC	Amps DC	DCµA	
Milliamps AC	Milliamps DC	°C	
Millivolts AC	Millivolts DC	°F	
Kilowatts	Watts	% pH	Ω
kg/cm <sup>2</sup>	Kilovolts AC	psi	
kWH	kVAR	Power Factor	
kΩ	CosØ	M/min	m <sup>2</sup> /hr

To customize the face plate, each UM-meter is supplied with a white printed clear adhesive label containing various popular descriptors. Choose the descriptor, peel off the adhesive backing and align the descriptor in the lower right corner of the standard face plate.

## Custom Face Plates

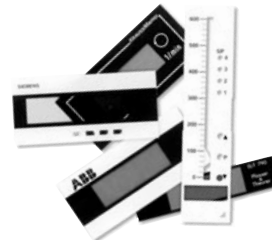

Texmate Produces Thousands of Custom OEM Face Plates

Have Texmate Design and produce a Custom Face Plate for your next project!

- Custom face plates have a non-recurring artwork charge. A serial number is then assigned to each artwork to facilitate reordering.

- Small Run or One-Off custom face plates incur an installation charge, and are generally printed on a special plastic film, which is then laminated to custom faceplate blanks as required.

- Large Run (250 pieces min): custom face plates are production silk screened, issued a part number, and held in stock for free installation as required by customer orders.

- OEMs may also order Custom Meter Labels, Box Labels, Custom Data Sheets and Instruction Manuals.

# UM Case Dimensions and Panel Cutouts

This NEMA Case will fit any existing cutout with dimensions that are between the Snug and Loose Fitting dimensions shown below.

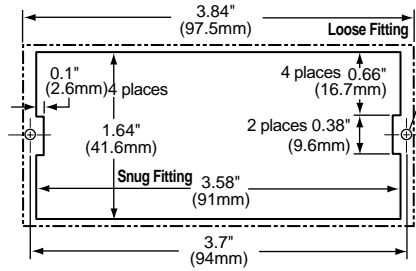

## Panel Cutout for Front Panel Removal

To enable removal of the panel meter from a mounting panel without requiring rear access, make the panel cutout as shown above, using the mounting plate supplied with the meter as a template. The mounting holes should then be tapped to match the mounting screws.

To remove the face plate, carefully insert screwdriver blade at bottom slot to release catch and gently pry outward to release the plate.

For new installations see Optimum Panel Cutout or Panel Cutout for Front Panel Removal

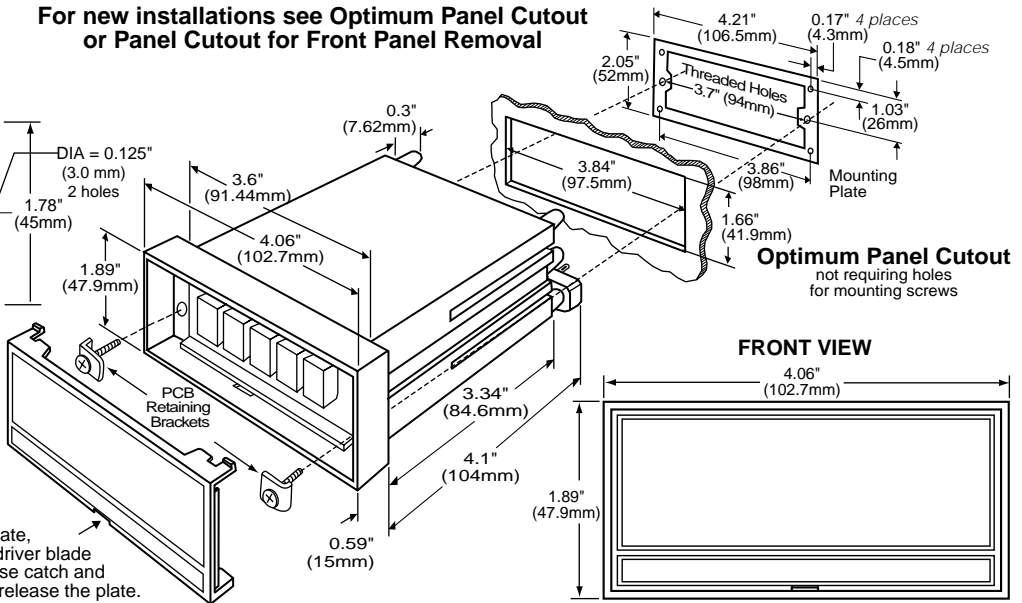

## FRONT VIEW

# Ordering Information

## Standard Options for this Model Number

**Part Number** Description List

► **BASIC MODEL NUMBER** Includes 2 TB-KITs, standard display and standard power supply unless optional versions are ordered.

UM-35JF	.....DPM, J thermocouple in °F	.....\$95
UM-35JC	.....DPM, J thermocouple in °C	.....\$95
UM-35KF	.....DPM, K thermocouple in °F	.....\$95
UM-35KC	.....DPM, K thermocouple in °C	.....\$95

## ► DISPLAY

STANDARD	....0.56" Red LEDs	.....N/C
UM-BRIGHT	.....Super bright Red LEDs, 0.56 inch high	.....\$20
UM-GREEN	.....Green LEDs, 0.56 inch high	.....\$10
UM-GREEN4.5	.....Green LEDs, 0.56 inch high Dummy Zero Option for UM-35s	.....\$25
UM-LARGE/GRN	.....Green LEDs, 0.8 inch high for UM-35 Series	.....\$35
UM-LARGE/RED	.....Red LEDs, 0.8 inch high for UM-35 Series	.....\$25
UM-RED4.5	.....Red LEDs, 0.56 inch high Dummy Zero Option for UM-35s	.....\$25

## ► POWER SUPPLY

STANDARD	....100/120 or 200/240VAC User selectable	.....N/C
V0-DC/ISO	.....Isolated auto-sensing AC/DC 9 to 36V DC/12 to 24V AC	.....\$35
V0-24V	.....Isolated transformer 12V AC or 24V AC user selectable	.....\$15
V0-5V DC	.....Non-isolated 5V DC only	.....\$10

## ► SPECIAL OPTIONS (Specify Inputs or Outputs & Req. Reading)

CB-FS35	.....Non-Std Range and Scale changes for UM-35 meters	.....\$10
---------	---	-----------

## Special Options and Accessories

**Part Number** Description List

### ► ACCESSORIES (Specify Serial # for Custom Artwork Installation)

75-RPCLEAR	.... Replacement Clear Lens for meter	.....\$2
75-RPFILTER	.... Replacement Red Lens for meter	.....\$2
CN-L15	.... Connector: Dual Row, 30 Pin Edge Conn., 0.156" ctr	.....\$4
CN-PUSH/UM	.... Connector: Push-on Terminal Block, 120V AC Pwr	.....\$18
CN-PUSH/UM01	.... Connector: Push-on Terminal Block, 200-240V AC Pwr	.....\$18
CN-PUSH/UM03	.... Connector: Push-on Terminal Block, 24V AC pwr	.....\$18
CN-PUSH/UM04	.... Connector: Push-on Terminal Block, 9 to 36V DC/12 to 24V AC	.....\$18
CN-PUSH/UM05	.... Connector: Push-on Terminal Block, 5V DC	.....\$18
CN-UM/ANLGC	.... Connector: Pinout Changer to match Analogic AN20M02 etc	.....\$30
OP-N4SEAL/UM	.... NEMA 4 lens cover for UM Series meters	.....\$50
RP-CASE	.... Case: Replacement with Mounting Hardware	.....\$10
TB-KIT	.... Connector: Extra Screw Terminal Blocks (3 sets=1 kit)	.....\$1
ART-FS-S/D	.... NRC for Artwork & set-up Custom Faceplate and or Descriptor	.....\$35
ART-FS-S/D/C	.... NRC for Artwork & set-up Custom Faceplate and Custom Logo	.....\$75
ART-FS-001	.... Produce & Install Custom Faceplate per meter - 1 color no-min	.....\$10
ART-FS-002	.... Produce & Install Custom Faceplate per meter - 2 color no-min	.....\$20
ART-FS-003	.... Produce & Install Custom Faceplate per meter - 3 color no-min	.....\$30
ART-FUM-001	.... Custom Faceplate, 100 piece Min. (\$3.00 each) - 1 color	.....\$300
ART-FUM-002	.... Custom Faceplate, 100 piece Min. (\$4.20 each) - 2 color	.....\$420
ART-FUM-003	.... Custom Faceplate, 100 piece Min. (\$5.40 each) - 3 color	.....\$540

Many other options and accessories are available. See full price list for more details. Prices subject to change without notice.

## WARRANTY

Textmate warrants that its products are free from defects in material and workmanship under normal use and service for a period of one year from date of shipment. Textmate's obligations under this warranty are limited to replacement or repair, at its option, at its factory, of any of the products which shall, within the applicable period after shipment, be returned to Textmate's facility, transportation charges pre-paid, and which are, after examination, disclosed to the satisfaction of Textmate to be thus defective. The warranty shall not apply to any equipment which shall have been repaired or altered, except by Textmate, or which shall have been subjected to misuse, negligence, or accident. In no case shall Textmate's liability exceed the original purchase price. The aforementioned provisions do not extend the original warranty period of any product which has been either repaired or replaced by Textmate.

## USER'S RESPONSIBILITY

We are pleased to offer suggestions on the use of our various products either by way of printed matter or through direct contact with our sales/application engineering staff. However, since we have no control over the use of our products once they are shipped, NO WARRANTY WHETHER OF MERCHANTABILITY, FITNESS FOR PURPOSE, OR OTHERWISE is made beyond the repair, replacement, or refund of purchase price at the sole discretion of Textmate. Users shall determine the suitability of the product for the intended application before using, and the users assume all risk and liability whatsoever in connection therewith, regardless of any of our suggestions or statements as to application or construction. In no event shall Textmate's liability, in law or otherwise, be in excess of the purchase price of the product.

Textmate cannot assume responsibility for any circuitry described. No circuit patent or software licenses are implied. Textmate reserves the right to change circuitry, operating software, specifications, and prices without notice at any time.



995 Park Center Drive • Vista, CA 92081-8397

Tel: 1-760-598-9899 • USA 1-800-839-6283 • That's 1-800-TEXMATE

Fax: 1-760-598-9828 • Email: sales@textmate.com • Web: www.textmate.com

Textmate has facilities in Japan, New Zealand, Taiwan, and Thailand. We also have authorized distributors throughout the USA and in 28 other countries.

For product details visit [www.textmate.com](http://www.textmate.com)

Local Distributor Address