



## PM-35U

5 Optional DC Input Ranges  
from 200mV to 1200V  
3 1/2 DIGIT with 0.3" LEDs  
In a Slim Bezel Case

A Low Cost Easy To Use General Purpose Meter.

### General Features

The PM-35U Digital Panel Meter is an economical, high performance instrument incorporating a number of features usually found only on more expensive meters. Utilizing the dual slope method of integration, the unit measures differential and single-ended DC voltages over five user selectable ranges from 199.9mV to 1200V full scale.

Maximum resolution is 100 $\mu$ V over  $\pm$ 1999 counts. Provision is made for user connections to provide various operating modes, including a ratiometric voltmeter, current meter, ratiometric ohmmeter, and a temperature difference meter.

The true differential input capability of the Model PM-35U is particularly useful for making accurate measurements of very small signals in the presence of much larger common mode signals.

Because of its high noise immunity, it is also ideal for measuring various balanced transducers and bridge inputs. When measuring bridge circuits, long term drift of the excitation voltage can be compensated for by using the ratiometric voltmeter mode of operation.

### Typical Application Connections

**SINGLE-ENDED METER- 200mV Range, >2V Range 200mV Range:** 1) Change R6 from 470k to 47k,  $\pm$ 5%; 2) Change R9 from 18.2k to 26.7k,  $\pm$ 1%; 3) Remove R8 (9.53k) and short with a jumper; 4) It is recommended that C4, C5 and C7 be changed to 0.22mF; 5) Adjust R10 until CV1=100mV.

**>2V Range:** Install R1 and R2 as specified under section titled Useful Tables.

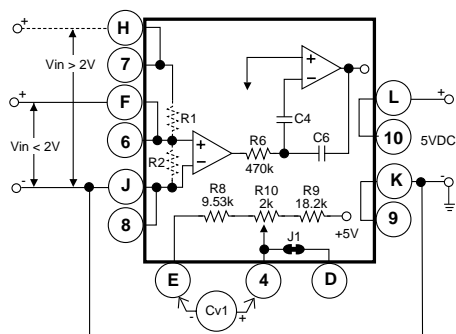

View more application connections and connection instructions on page 3.

### PM-Series, high performance versatility for a wide range of applications

PM-35A.....	3.5 digit Red LED, Precision Preference, 2VDC, 5VDC Power
PM-35AR .....	3.5 digit Red LED, Autoranging, 200mV/2VDC, 5VDC Power
PM-35U .....	3.5 digit Red LED, Low Cost, 2VDC, 5VDC Power
PM-35X.....	3.5 digit LCD, Low Power Consumption 2VDC, 5VDC Power
PM-35XAR .....	3.5 digit LCD, Low Power Autoranging
PM-35XAC110 .....	3.5 digit LCD, 2VDC, 120VAC Power
PM-35XACAR1 .....	3.5 digit LCD, Autoranging, 120VAC Power
PM-45L.....	4.5 digit Red LED, Precision Meter w/Differential Input
PM-45LBCD .....	PM-45L w/Tri-State Parallel BCD Output, 5VDC Power
PM-45LMUXBCD .....	PM-45L w/Multiplexed BCD Output

### Compatibility

The PM-35U is shipped in a standard Slim Bezel case. The Slim Bezel case is compatible with the CM, SM, TM, & SP Series of meters. The PM-35U can be ordered in End Mount cases for twin mounting or combinations of multiple center mount cases and two end mount cases for stack mounting.

#### SLIM



#### BEZEL

### Specifications

**Input Configuration:**.....True differential and single-ended

**Full Scale Ranges:** ..... $\pm$ 199.9mVDC  
 $\pm$ 1.999VDC (standard)  
 $\pm$ 19.99VDC  
 $\pm$ 199.9VDC  
 $\pm$ 1200VDC

**Input Impedance:** .....Exceeds 1000M $\Omega$  on 200mV and 2V ranges; 10M $\Omega$  on all other ranges

**Input Protection:**..... $\pm$ 250VDC or 175VAC maximum on 200mV and 2V ranges;  $\pm$ 1200VDC or 850VAC on all other ranges

**Accuracy:** ..... $\pm$ (0.1% of reading + 1 digit)

**Temperature Coefficient:** ..5PPM/ $^{\circ}$ C in ratiometric operation; 80 to 100PPM/ $^{\circ}$ C using internal reference on 200mV and 2V ranges

**Warm Up Time:** .....2 minutes to specified accuracy

**Conversion Rate:** .....3 readings per second nominal

**Display:** .....0.3" LED

**Decimal Selection:** .....User programmable to 4 positions

**Overrange Indication:** ..When input exceeds full scale on any range being used, most significant "1" digit & polarity symbol are displayed with all other digits blank

**Power Requirements:**.....+4.5 to +5.5VDC at 200mA max.

**Operating Temperature:** .....0 $^{\circ}$  to +60 $^{\circ}$ C

**Storage Temperature:**.....-20 $^{\circ}$  to +70 $^{\circ}$ C

**Relative Humidity** .....95% (non-condensing)

**Case Dimensions:** .....Bezel 2.76" x 1.17" (69.75 x 29.7mm)  
 Depth behind Bezel 3.32"(84mm) plus 0.68" (17.27mm) for connector.

**Weight:** .....88 gms (3.1 oz)

## Functional Diagram

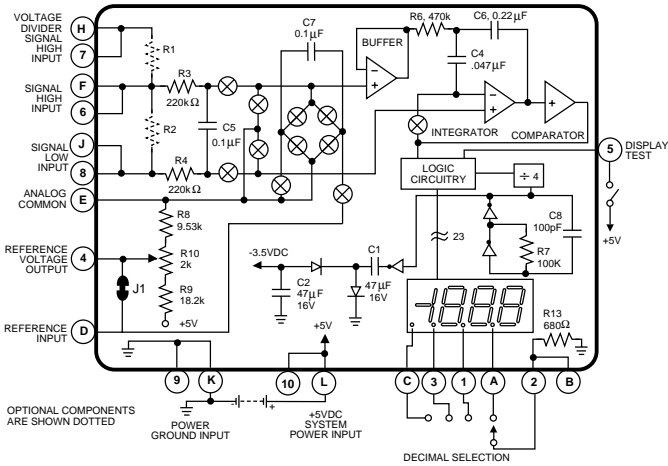

## Connector Pinouts

The Texmate Model PM-35U interconnects by means of a standard PC board edge connector having two rows of 10 pins, spaced on 0.156" centers. Connector are available from Texmate, or from almost any connector manufacturer. Provision has also been made for direct solder termination to the PC board, thus eliminating the need for a connector. Please note that the warranty will be void if there is any damage due to soldering.

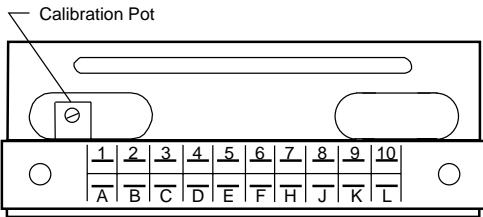

Component Side	Solder Side
DECIMAL SELECT (1X.XX) 1	A DECIMAL SELECT (1XX.X)
DECIMAL SELECT COMMON 2	B DECIMAL DECIMAL SELECT COMMON
DECIMAL SELECT (1.XXX) 3	C DECIMAL SELECT (1XXX)
REFERENCE VOLTAGE OUTPUT 4	D REFERENCE INPUT
DISPLAY TEST 5	E ANALOG COMMON
SIGNAL HIGH INPUT 6	F SIGNAL HIGH INPUT
VOLTAGE DIVIDER SIGNAL HIGH INPUT 7	H VOLTAGE DIVIDER SIGNAL HIGH INPUT
SIGNAL LOW INPUT 8	J SIGNAL LOW INPUT
POWER GROUND INPUT 9	K POWER GROUND INPUT
+5VDC SYSTEM POWER INPUT 10	L +5VDC SYSTEM POWER INPUT

**CAUTION:** This meter employs high impedance CMOS inputs. Although internal protection has been provided for several hundred volt overloads, the meter will be destroyed if subjected to the high kilovolts of static discharge that can be produced in low humidity environments. Always handle the meter with ground protection.

**Pins A, C, 1 and 3- Decimal Select:** Decimal points may be displayed as required by connecting appropriate pin to Decimal Select Common Pins B or 2.

**Pins B and 2- Decimal Select Common:** Decimal points are displayed as required by connecting Pins B or 2 to the appropriate Decimal Select Pins A, C, 1, or 3.

**Pin D- Reference Input:** Reference voltage input for A to D converter. Normally supplied from Reference Voltage Output Pin 4 which is internally jumpered to Pin D by way of Junction J1. Pin D may be used as an input for ratiometric measurements. Minimum usable voltage is .05VDC with +4.0VDC being the maximum.

**Pin E- Analog Common:** 2.8V output referenced to +5V System Power Input L, approximately +2.2V output referenced to Power Ground Input Pin K.

**Pins F and 6- Signal High Input:** Signal high input of A to D converter. Maximum overvoltage protection is 250VDC or 175VAC.

**Pins H and 7- Voltage Divider Signal High Input:** Signal high input for voltages that require attenuation or scaling. Dividing resistors

R1 and R2 may be mounted internally for voltages up to 1200V max. Matched dividing resistors for 2V (1/10), 200V (1/100), and 1200V (1/1000) ranges are available from Texmate. Shunt resistors for current measurements up to 200mA may be internally mounted in the R2 position. The current loop is then applied to Signal High Input Pin F and returned through Pin J or Pin 8.

**Pins J and 8- Signal Low Input:** Signal low input of A to D converter. Maximum overvoltage protection is 250VDC or 175VAC.

**Pins K and 9- Power Ground Input:** Negative terminal of +5VDC power should be connected to Pin 9. All digital signals, decimal points, display test, and overrange should be returned to this ground point.

**Pins L and 10- +5VDC System Power Input:** Meter requires regulated ( $\pm 10\%$ ) 5VDC power at approximately 200mA.

**Pin 4- Reference Voltage Output:** Internal precision voltage reference. Standard output is 1.000V, adjustable to  $\pm 5\%$  by R10 potentiometer. Usable voltages from .05V to 2.8V for special high impedance scaling can be obtained by changing the value of internal dividing resistors R8 and R9.

**Pin 5- Display Test:** All segments will light up when Pin 5 is connected to +5VDC System Power Input Pin L or Pin 10.

## Component Layout

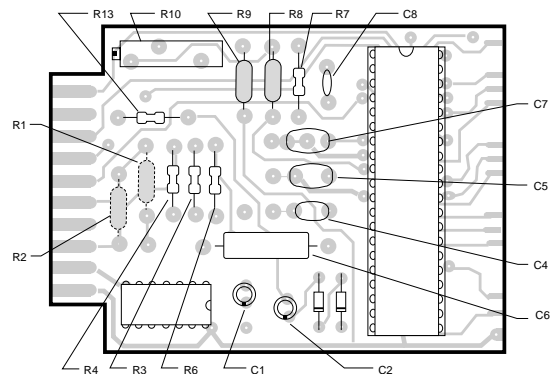

COMPONENT SIDE

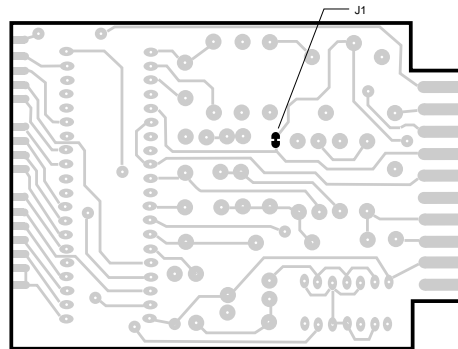

SOLDER SIDE

## Signal Conditioning Components

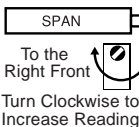

### SPAN Potentiometer (Pot)

The SPAN pot is on the right side of the display. Typical adjustment is 20% of the input signal range.

## Calibration Procedure

Apply power to the meter. Then with a precision DC reference source, apply +1.900VDC between the Signal High Input Pin F and the Signal Low Input Pin J. Adjust R10 potentiometer (on left side as viewed from rear) until the display reads +1.9900V. **Note:** The voltage applied in this case is for a  $\pm 1.999V$  F.S. meter. For other ranges, the voltage applied should be similarly proportionate to the particular full scale voltage.



## PM Case Dimensions and Panel Cutouts

The Slim Bezel Case is supplied as standard. If specified at time of ordering, any combination of Twin Mounting and Multiple Array Cases may be substituted at no additional cost. Extra cases may be ordered separately.

### STANDARD SLIM BEZEL CASE

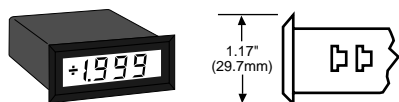

**SLIM BEZEL CASE**  
Standard Black ABS case with matte finish bezel for single unit mounting.

Part No. **SL-CASERED** for LED's  
**SL-CASECLR** for LCD's

### OPTIONAL TWIN MOUNTING OR MULTIPLE ARRAY CASES

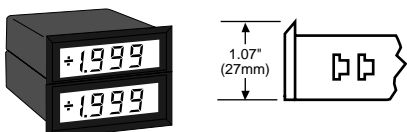

**END MOUNT CASE**  
Same styling as Slim Bezel case but with bottom edge of bezel removed. Two End Mount cases can be twin mounted in a single cutout.

Part No. **EM-CASERED** for LED's  
**EM-CASECLR** for LCD's

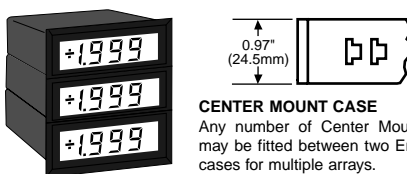

**CENTER MOUNT CASE**  
Any number of Center Mount cases may be fitted between two End Mount cases for multiple arrays.

Part No. **CM-CASERED** for LED's  
**CM-CASECLR** for LCD's

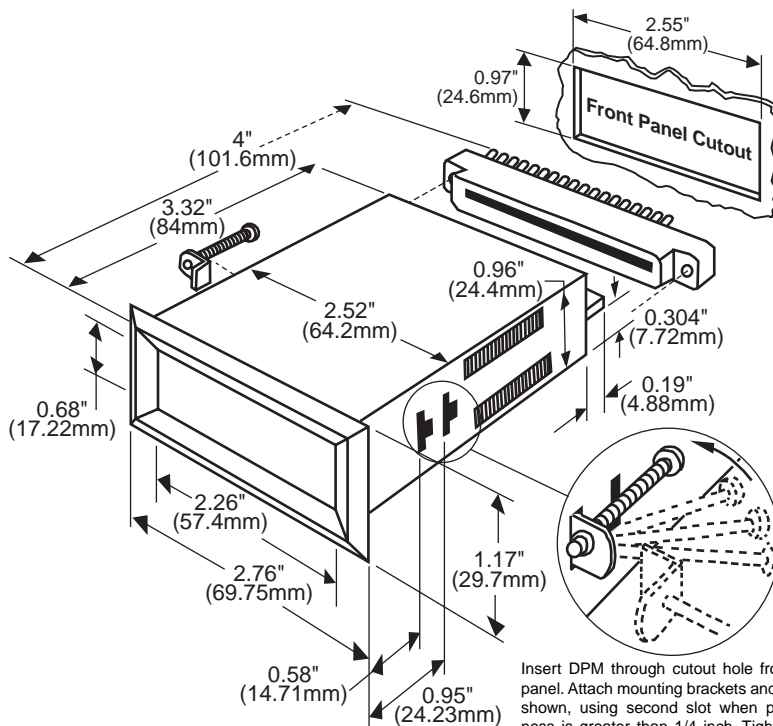

Insert DPM through cutout hole from front of panel. Attach mounting brackets and screws as shown, using second slot when panel thickness is greater than 1/4 inch. Tighten screws against rear of panel.

## Ordering Information

### Standard Options for this Model Number

Part Number .Description

#### ► BASIC MODEL NUMBER

PM-35U . . . . .3.5 digit Red LED, Low Cost, 2VDC, 5VDC pwr

**Note:** For operation, the PM-35U requires a CN-L10 Dual Row 10 Pin PCB edge connector 0.156" center or equivalent (see accessories).

### Special Options and Accessories

Part Number .Description

#### ► SPECIAL OPTIONS (Specify Inputs & Req. Reading)

VA-200MVFI . . . . .200mVDC Range Change

VF-0020V . . . . .20VDC Range Change

VF-0200V . . . . .200VDC Range Change for 3.5 digit PM Series

VF-1200V . . . . .1200VDC Range Change for 3.5 digit PM Series  
VS-3.5 . . . . .Non-Std Range and Scale - 3.5 Digit PM Meters

#### ► ACCESSORIES



CN-L10 . . . . .Dual Row 10 Pin PCB Edge Connector, 0.156" ctr Solder Eyelets

SL.CASERED . . . . .Slim Bezel Case, Red Faceplate w/Mtg Hardware

CL.CASERED . . . . .Center Mount Case, Red Faceplate w/Mtg Hardware

EM.CASERED . . . . .End Mount Case, Red Faceplate w/Mtg Hardware

Prices subject to change without notice.

### WARRANTY

Texmate warrants that its products are free from defects in material and workmanship under normal use and service for a period of one year from date of shipment. Texmate's obligations under this warranty are limited to replacement or repair, at its option, at its factory, of any of the products which shall, within the applicable period after shipment, be returned to Texmate's facility, transportation charges pre-paid, and which are, after examination, disclosed to the satisfaction of Texmate to be thus defective. The warranty shall not apply to any equipment which shall have been repaired or altered, except by Texmate, or which shall have been subjected to misuse, negligence, or accident. In no case shall Texmate's liability exceed the original purchase price. The aforementioned provisions do not extend the original warranty period of any product which has been either repaired or replaced by Texmate.

### USER'S RESPONSIBILITY

We are pleased to offer suggestions on the use of our various products either by way of printed matter or through direct contact with our sales/application engineering staff. However, since we have no control over the use of our products once they are shipped, NO WARRANTY WHETHER OF MERCHANTABILITY, FITNESS FOR PURPOSE, OR OTHERWISE is made beyond the repair, replacement, or refund of purchase price at the sole discretion of Texmate. Users shall determine the suitability of the product for the intended application before using, and the users assume all risk and liability whatsoever in connection therewith, regardless of any of our suggestions or statements as to application or construction. In no event shall Texmate's liability, in law or otherwise, be in excess of the purchase price of the product.

Texmate cannot assume responsibility for any circuitry described. No circuit patent or software licenses are implied. Texmate reserves the right to change circuitry, operating software, specifications, and prices without notice at any time.



995 Park Center Drive • Vista, CA 92081-8397

Tel: 1-760-598-9899 • USA 1-800-839-6283 • That's 1-800-TEXMATE

Fax: 1-760-598-9828 • Email: sales@texmate.com • Web: www.texmate.com

Texmate has facilities in Japan, New Zealand, Taiwan, and Thailand. We also have authorized distributors throughout the USA and in 28 other countries.

For product details visit [www.texmate.com](http://www.texmate.com)

Local Distributor Address