

TEXMATE

PM-35XAC110

115 VAC Powered Panel Meter

PM-35XACAR1

Autoranging Version of XAC110
Both have 3 1/2 DIGIT with .48" LCD
in a Slim Bezel Case

110 / 220VAC Powered LCD Differential Input and Autoranging Meters.

General Features

The PM-35XAC is a precision AC powered panel meter that measures true differential and single-ended DC voltages over five user programmable ranges from $\pm 199.9\text{mV}$ to $\pm 1200\text{V}$ full scale. The 1500V isolation provided by the internally mounted miniature 110 or 220VAC mains transformer eliminates most of the troublesome ground loop problems associated with DC powered DPM's. Alternatively, where appropriate, a DC power supply of 9 to 15VDC can be used. Since the meter draws only a small constant current, operation from higher DC voltages is also possible merely by use of a voltage dropping resistor in series with the meter.

The true differential capability of the Model PM-35XAC permits accurate measurements of very small input signals in presence of much larger common mode signals. It is ideal for measuring various balanced transducers and bridge inputs.

The high contrast long-life liquid crystal display also offers 8 user programmable descriptors for direct indication of the type and range of signals being measured.

Typical Application Connections

SINGLE-ENDED METER - 200mV RANGE, >2V RANGE
For 200mV Range: 1) Omit R1 and R2; 2) Change R6 from 470k Ω to 47k Ω ; 3) Change R8 from 619 Ω to 121 Ω ; 4) Change R9 from 4.32k Ω to 12.1k Ω ; 5) Change C4 from 0.047 μF to 0.33 μF ; 6) Change C7 from 0.1 μF to 2.2 μF . **For >2V RANGE:** 1) Install R1 and R2 as specified under section titled Useful Tables.

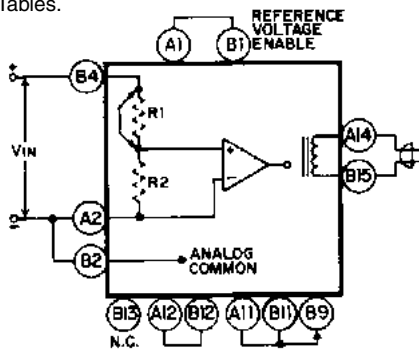

View more application connections and connection instructions on page 3.

Compatibility

The PM-35XAC is shipped in a standard Slim Bezel case. The Slim Bezel case is compatible with the CM, SM, TM, & SP Series of meters. The PM-35U can be ordered in End Mount cases for twin mounting or combinations of multiple center mount cases and two end mount cases for stack mounting.

SLIM



BEZEL

Specifications

- Input Configuration:** True differential and single-ended
- Full Scale Ranges:** $\pm 199.9\text{mVDC}$
 $\pm 1.999\text{VDC}$ (standard)
 $\pm 19.99\text{VDC}$
 $\pm 199.9\text{VDC}$
 $\pm 1200\text{VDC}$
- Input Impedance:** Exceeds 1000M Ω on 200mV and 2V ranges; 10M Ω on all other ranges
- Input Protection:** $\pm 500\text{VDC}$ or 350VAC maximum on 200mV and 2V ranges; $\pm 1200\text{VDC}$ or 850VAC on all other ranges
- Accuracy:** $\pm (0.05\%$ of reading + 1 digit)
- Temperature Coefficient:** 5PPM/ $^{\circ}\text{C}$ in ratiometric operation; 50 PPM/ $^{\circ}\text{C}$ Typ. using internal reference on 200mV and 2V ranges
- Warm Up Time:** 10 seconds to specified accuracy
- Conversion Rate:** 3 readings per second nominal; user programmable from 1 to 10 readings per second
- Display:** 0.48" LCD
- Decimal Selection:** User programmable to 3 positions
- Overrange Indication:** When input exceeds full scale on any range being used, most significant "1" digit & polarity symbol are displayed with all other digits blank
- Power Requirements:** 110VAC or 220VAC, 5% at 50Hz, 117V or 230VAC, 5% at 60Hz and 400Hz. Regulated 9VDC to 15VDC at 6mA to 15mA
- Operating Temperature:** 0° to $+60^{\circ}\text{C}$
- Storage Temperature:** -20° to $+70^{\circ}\text{C}$
- Relative Humidity:** 95% (non-condensing)
- Case Dimensions:** Bezel 2.76" x 1.17" (69.75 x 29.7mm)
Depth behind Bezel 3.32" (84mm) plus 0.68" (17.27mm) for connector.
- Weight:** 88 gms (3.1 oz)

PM-Series, high performance versatility for a wide range of applications

- PM-35A 3.5 digit Red LED, Precision Preference, 2VDC, 5VDC Power
- PM-35AR 3.5 digit Red LED, Autoranging, 200mV/2VDC, 5VDC Power
- PM-35U 3.5 digit Red LED, Low Cost, 2VDC, 5VDC Power
- PM-35X 3.5 digit LCD, Low Power Consumption 2VDC, 5VDC Power
- PM-35XAR 3.5 digit LCD, Low Power Autoranging
- PM-35XAC110 3.5 digit LCD, 2VDC, 120VAC Power
- PM-35XACAR1 3.5 digit LCD, Autoranging, 120VAC Power
- PM-45L 4.5 digit Red LED, Precision Meter w/Differential Input
- PM-45LBCD PM-45L w/Tri-State Parallel BCD Output, 5VDC Power
- PM-45LMUXBCD PM-45L w/Multiplexed BCD Output

- PM-45LU 4.5 digit Red LED, Low Cost Meter w/Differential Input
- PM-45LUBCD PM-45LU w/Tri-State Parallel BCD Output
- PM-45LUMXBCD PM-45LU w/Multiplexed BCD Output
- PM-45X 4.5 digit LCD, Precision Meter w/Differential Input
- PM-45XBCD PM-45X w/Tri-State Parallel BCD Output, 5VDC Power
- PM-45XMUXBCD PM-45X w/Multiplexed BCD Output, 5VDC Power
- PM-45XU 3.5 digit LCD, Low Cost Meter w/Differential Input
- PM-45XUBCD PM-45XU w/Tri-State Parallel BCD Output, 5VDC Power
- PM-45XUMXBCD PM-45XU w/Multiplexed BCD Output, 5VDC Power

Functional Diagram

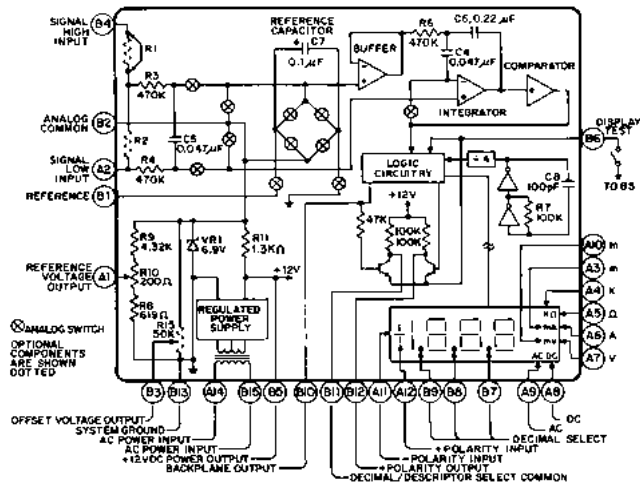

Connector Pinouts

The Texmate Model PM-35XAC interconnects by means of a standard PC board edge connector having two rows of 15 pins each, spaced on 0.1" centers. Connectors are available from Texmate, or from almost any connector manufacturer.

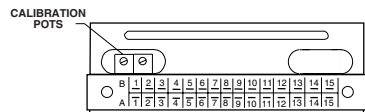

Component Side	Solder Side
REFERENCE INPUT B1	A1 REFERENCE VOLTAGE OUTPUT
ANALOG COMMON B2	A2 SIGNAL LOW INPUT
OFFSET VOLTAGE OUTPUT B3	A3 "m" FOR mA DESCRIPTOR
SIGNAL HIGH INPUT B4	A4 K DESCRIPTOR
+12VDC POWER OUTPUT B5	A5 Ω DESCRIPTOR
DISPLAY TEST B6	A6 A DESCRIPTOR
DECIMAL SELECT (1XX.X) B7	A7 V DESCRIPTOR
DECIMAL SELECT (1X.XX) B8	A8 DC DESCRIPTOR
DECIMAL SELECT (1.XXX) B9	A9 AC DESCRIPTOR
BACKPLANE OUTPUT B10	A10 "m" FOR mV DESCRIPTOR
DECIMAL / DESCRIPTOR SELECT COMMON B11	A11 "-." POLARITY SIGN INPUT
"+" POLARITY SIGN OUTPUT B12	A12 "+" POLARITY SIGN INPUT
SYSTEM GROUND B13	A13 NO CONNECTION
NO CONNECTION B14	A14 AC POWER INPUT
AC POWER INPUT B15	A15 NO CONNECTION

CAUTION: This meter employs high impedance CMOS inputs. Although internal protection has been provided for several hundred volt overloads, the meter will be destroyed if subjected to the high kilovolts of static discharge that can be produced in low humidity environments. Always handle the meter with ground protection.

Pin A1 - Reference Voltage Output: Internal precision voltage reference. Standard output is 1.000V, adjustable by ±5% with R10 potentiometer. Usable voltages from 0.05V to 5.0V for special high impedance scaling can be obtained by changing the value of internal dividing resistors R8 and R9. It should be noted that when Pin A1 is referred to System Ground Pin B13 the potential is +1.0V. However, when Pin A1 is referred to Analog Common Pin B2, the potential is -5.9V.

Pin A2 - Signal Low Input: Signal low input of A to D converter. Maximum over-voltage protection is ±500VDC or 350VAC.

Pins A3, A4, A5, A6, A7, A8, A9 and A10 - Descriptors: These are the pins for the descriptors "m" for mA, K, Ω, A, V, DC, AC, and "m" for mV, respectively. They may be displayed as required by connecting the appropriate pin(s) to Decimal/Descriptor Select Common Pin B11; any number of descriptors can be turned on at the same time. An open circuit will turn off a descriptor; however, static current pickup and/or PCB leakage of more than 100nA can cause descriptors to turn on undesirably. Therefore, it is recommended that any unused descriptors be connected to Backplane Output Pin B10 either directly or by a resistor of less than 5MΩ to insure an off condition. **CAUTION:** Any DC component introduced to the display drive circuitry can, in time, cause permanent damage.

Pin A11 - "-." Polarity Sign Input: Pin A11 is the negative sign segment of LCD. For normal operation, Pin A11 is connected to Decimal/Descriptor Select Common Pin B11. For reversed polarity sign indication, connect Pin A11 to "+" Polarity Sign Output Pin B12 and connect "+" Polarity Sign Output Pin A12 to Backplane Output Pin B10. This will cause the minus sign to be displayed when a positive signal is present. However, in this configuration the plus sign must be assumed when a negative signal is present.

Pins A12 - "+" Polarity Sign Input: Pin A12 is the positive sign segment of the LCD. For normal operation, Pin A12 is connected to "+" Polarity Sign Output Pin B12. SEE DESCRIPTION OF PIN A11 FOR REVERSED POLARITY OPERATION.

Pins A13, A14, and A15 - No Connection: The PCB pads which would normally correspond to these pins do not exist on the PCB.

Pin A14 - AC Power Input: Connect one side of the 117V or 230VAC power input to Pin B15.

to Pin A14. Model PM-35XAC110 is operated from 110V at 50Hz or 117V at 60Hz to 400Hz. Model PM-35XAC220 is operated from 220V at 50Hz or 230V at 60Hz to 400Hz.

Pin B1 - Reference Input: Reference voltage input for A to D converter. Normally supplied from Pin A1. An external reference source referred to Pin B13 may be used instead. Pin A1 may be used as an input for ratiometric measurements. Minimum usable voltage is 0.05VDC, with a maximum voltage of 5.0V. For ratiometric operation, displayed reading = 1000 X (Signal input Voltage - Reference input Voltage). The maximum signal input voltage is 5V. Higher voltages must be scaled down through a voltage divider. Reference input voltage must remain stable during measurement period. **NOTE:** Consideration should be given to the common mode voltage of the input signal as the system common mode voltage range referred to Analog common Pin B2 is -5V to +2V whereas referred to System Ground Input Pin B13 the common mode voltage range is +2V to +8V.

Pin B2 - Analog Common: Pin B2 is common for the analog section of the meter which is normally +6.9V above System Ground Input Pin B13. Pin B2 should not be connected to System Ground Input Pin B13 due to the fact that Analog Common is regulated to provide the primary precision voltage source for the Reference Voltage Output Pin A1. This voltage is also the source from which the offset voltage Output Pin B3 is derived.

Pin B3 - Offset Voltage Output: With the addition of a 3/4" 50KΩ potentiometer in the R15 position on the PC board, 0 to +6.9V is available from Pin B3 which is referred to either system Ground Pin B13 or Analog common Pin B2.

Pin B4 - Signal High Input: Pin B4 is the signal high input for all input signals. When attenuation is not required, the resistor position R1 should be shorted by a jumper. Dividing resistors may be mounted internally in R1 and R2 positions to attenuate voltages up to 1200V max. Matched dividing resistors for the 20V (1/10), 200V (1/100), and 1200V (1/1000) ranges are available from Texmate. Shunt resistors for current measurements up to 200mA may also be internally mounted in the R2 position. The current loop is then applied to Pin B4 and returned through Signal Low Input Pin A2.

Pin B5 - +12VDC Power Output: When the meter is operated from an AC source, Pin B5 provides a +12VDC output, which may be used to power external circuitry. The maximum auxiliary load is 1mA. When the meter is powered from a 9 to 15VDC source, Pin B5 becomes the positive terminal of the power input. **NOTE:** In some circuit configurations the input signal must be isolated from the DC power supply.

Pin B6 - Display Test: All display segments will operate when Pin B6 is connected to 12VDC Power Output Pin B5. The Display Test function is only intended for momentary operation. Continuous application of Display Test will in time damage the display.

Pins B7, B8, and B9 - Decimal Select: Decimal points may be displayed as required by connecting appropriate pin to Decimal/Descriptor Select Common Pin B11. **CAUTION:** Decimal display pins have the same operating characteristics as Descriptor pins and likewise may be damaged from a DC component introduced by leakage or inadvertent connection to system ground.

Pin B10 - Backplane Output: Liquid crystal displays are operated from an AC signal. The backplane is the common base of the LCD capacitance structure and is continuously driven by a square-wave signal at approximately 60Hz. Those segments that are driven 180° out-of-phase with Pin B10 will turn on. Those segments that are driven in-phase with Pin B10 will turn off.

PIN B11 - Decimal/Descriptor Select Common: Pin B11 is 180° out-of-phase with Backplane Output Pin B10. Thus, it serves as a common for the descriptors, decimal select, and the "-" polarity sign. As required, Pin B11 may be connected to Decimal Select Pins B7, B8, B9 and to Descriptor Pins A3, A4, A5, A6, A7, A8, A9, A10. The "-" Polarity Sign Input Pin A11 is also connected to Pin B11 for standard polarity indication.

Pin B12 - "+" Polarity Sign Output: Pin B12 is in-phase with Backplane Output Pin B10 for negative signal inputs and out-of-phase for positive signal inputs. Connect Pin B12 to "+" Polarity Sign Input Pin A12 for normal operation. SEE DESCRIPTION OF PIN A11 FOR REVERSED POLARITY OPERATION.

Pin B13 - System Ground: Pin B13 is the ground return for +12VDC Power Output, and serves as AC Power Ground Input (negative side of power supply) when the meter is powered from 9 to 15VDC source.

Pin B15 - AC Power Input: Connect one side of the 117V or 230VAC power input to Pin B15.

Component Layout

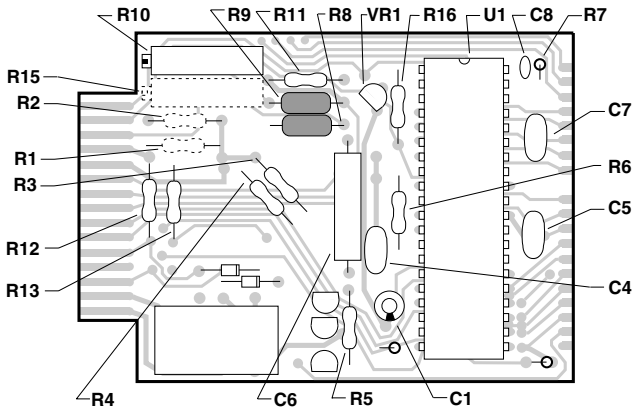

Calibration Procedure

After making the appropriate connections as shown in the instructions apply power to the meter. Then, with a precision DC reference source, apply +1.900VDC between Signal High Input Pin B4 and Signal Low Input Pin A2. Adjust R10 potentiometer (on left side as viewed from rear) until the display reads +1.900V. **NOTE:** This calibration voltage is for a ±1.999V F.S. meter. For other ranges, the voltage applied should be similarly proportionate to the selected full scale voltage.

Signal Conditioning Components

SPAN SPAN Potentiometer (Pot)

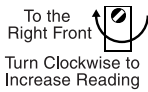

The SPAN pot is on the right side of the display. Typical adjustment is 20% of the input signal range.

ZERO ZERO Potentiometer (Pot) optional

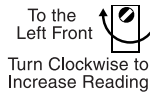

The ZERO pot is on the right side of the SPAN Pot. Typically it enables the displayed reading to be offset ± 500 counts.

Typical Application Connections

The PM-35XAC may be used in a wide variety of configurations. The following circuits illustrate some of the possibilities and demonstrate the exceptional versatility of Texmate products. Components called for in the applications which are not part of the standard meter may be supplied by the user or in some cases purchased from Texmate. The circuit diagrams explain the basic pinout connections required for each application. Unless otherwise specified, the diagrams will show the component values and solder junctions that would normally be installed on a standard 2V range meter. For those applications which have alternative ranges and/or input configurations, the required component values and any modifications are described in the text.

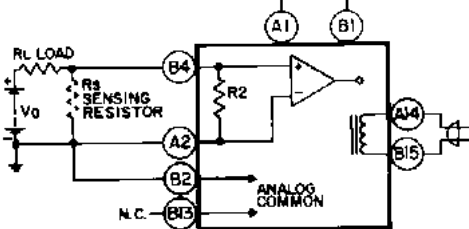

SINGLE-ENDED CURRENT METER

1) Connect meter as for 200mV voltmeter; 2) Install R_S NOTE: R_S must be externally mounted when F.S. current is greater than 200mA, and 4-wire type connection should be used. For currents of 200mA F.S. or less, R_S may be internally mounted in the R2 position. Standard values for R_S are specified under section titled Useful Tables.

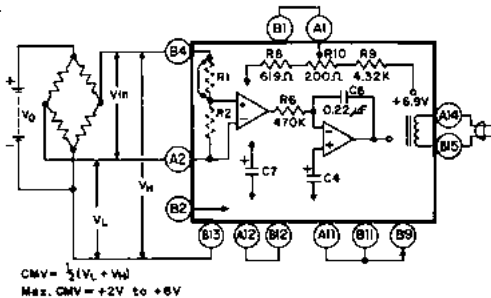

DIFFERENTIAL METER - 200mV RANGE, 2V RANGE WITH COMMON MODE VOLTAGE FROM -2.8V TO +2.8V

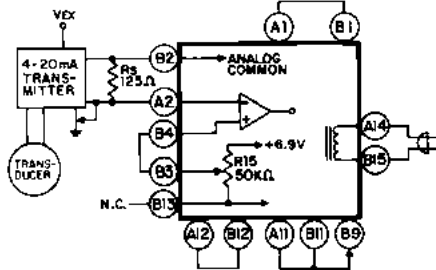

For 200mV Range: 1) Omit R1 and R2; 2) Change R6 from 470k Ω to 47k Ω ; 3) Change R8 from 619 Ω to 121 Ω ; 4) Change R9 from 4.3k Ω to 12.1k Ω ; 5) Change C4 from 0.047 μ F to 0.33 μ F; 6) Change C7 from 0.1 μ F to 2.2 μ F.

For >2V Range: Install R1 and R2 as specified under section titled Useful Tables.



BATTERY OPERATED 4 TO 20mA RECEIVER

1) Install 125 Ω resistor in R_S position; 2) Install R15 potentiometer using any value between a minimum of 20k Ω and a maximum of 100k Ω .

NOTE: Use of these application circuits is entirely at the risk and responsibility of the user and any user modification of the meter may at the discretion of Texmate, void the warranty. (See rear page for user's responsibility and warranty details) The following legend applies to all application circuits: 1) optional component positions are shown in dotted lines; 2) internal solder junctions are shown by  for a closed junction or  for an open junction; 3) calibration voltages as measured by an external user supplied voltmeter are shown by 

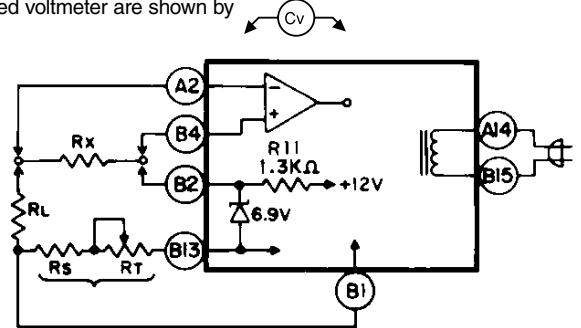

DIFFERENTIAL RATIO-METRIC OHMMETER

1) Install R_S and R_T specified under section titled Useful Tables; 2) Install R_L with a value equal to $3 \times (R_S + R_T)$ for use as a current limiting resistor.

NOTE: Full Scale Range = $(R_S + R_T) \times 2$

Displayed Reading = $R_X \div (R_S + R_T) \times 1000$.

R_X is device under measurement.

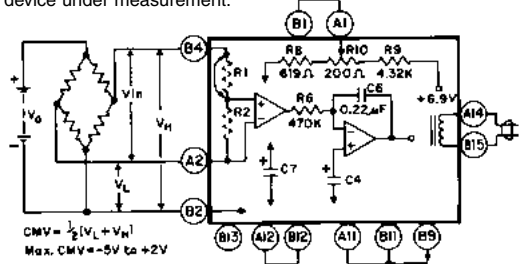

DIFFERENTIAL METER: 200mV RANGE, >2V RANGE WITH COMMON MODE VOLTAGE FROM -5V TO +2V

For 200mV Range: 1) Omit R1 and R2; 2) Change R6 from 470k Ω to 47k Ω ; 3) Change R8 from 619 Ω to 121 Ω ; 4) Change R9 from 4.3k Ω to 12.1k Ω ; 5) Change C4 from 0.047 μ F to 0.33 μ F; 6) Change C7 from 0.1 μ F to 2.2 μ F.

For >2V Range: Install R1 and R2 as specified under section titled Useful Tables.

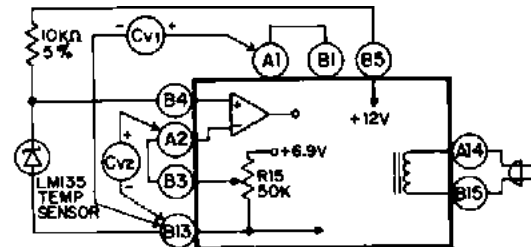

TEMPERATURE METER WITH OFFSET CAPABILITY

1) Install R15, minimum of 20k Ω maximum of 100k Ω ; 2) Adjust R10 until $C_{V1} = 1.000V$; Adjust R15 until $C_{V2} = 2.732V$ for -50.0 $^{\circ}$ C to +150.0 $^{\circ}$ C. Special scaling is required for $^{\circ}$ F.

Useful Tables

VOLTAGE RANGE CHANGE				CURRENT RANGE CHANGE (*)			OHMMETER RANGE CHANGE		
F.S. In	R1	R2	Resolution	Use 200mV F.S. meter for minimum voltage drop.			F.S. In	$R_S + R_T$	Resolution
200mV	omit	omit	100 μ V	F.S. In	R_S External	Resolution	200	100	100m
2V	omit	omit	1mV	20A	0.01	10mA	2k	1k	1
20V	9M	1M	10mV	2A	0.1	1mA	20k	10k	10
200V	10M	100k	100mV	F.S. In	R_S Internal	Resolution	200k	100k	100
1200V	10M	10k	1V	200mA	1	100 μ A	2M	1M	1k
				20mA	10	10 μ A	20M	10M	10k
				2mA	100	1 μ A			
				200 μ A	1k	100nA			

PM Case Dimensions and Panel Cutouts

The Slim Bezel Case is supplied as standard. If specified at time of ordering, any combination of Twin Mounting and Multiple Array Cases may be substituted at no additional cost. Extra cases may be ordered separately.

STANDARD SLIM BEZEL CASE

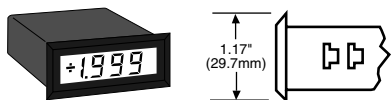

SLIM BEZEL CASE

Standard Black ABS case with matte finish bezel for single unit mounting.

Part No. **SL-CASERED** for LED's
SL-CASECLR for LCD's

OPTIONAL TWIN MOUNTING OR MULTIPLE ARRAY CASES

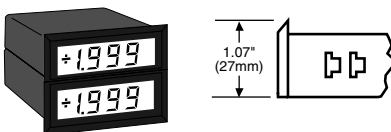

END MOUNT CASE

Same styling as Slim Bezel case but with bottom edge of bezel removed. Two End Mount cases can be twin mounted in a single cutout.

Part No. **EM-CASERED** for LED's
EM-CASECLR for LCD's

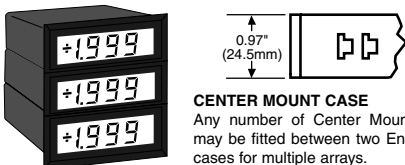

CENTER MOUNT CASE

Any number of Center Mount cases may be fitted between two End Mount cases for multiple arrays.

Part No. **CM-CASERED** for LED's
CM-CASECLR for LCD's

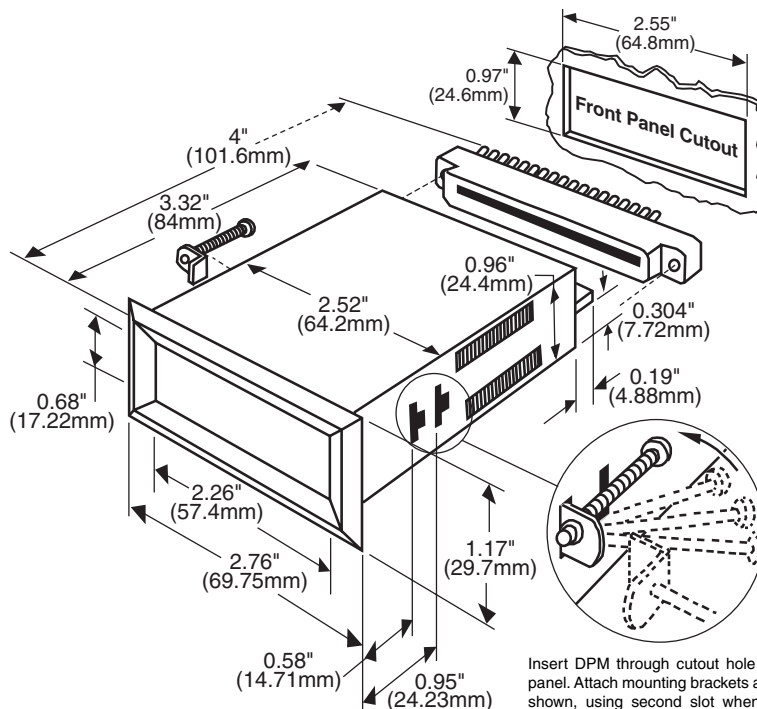

Insert DPM through cutout hole from front of panel. Attach mounting brackets and screws as shown, using second slot when panel thickness is greater than 1/4 inch. Tighten screws against rear of panel.

Ordering Information

Standard Options for this Model Number

Part Number .Description

► BASIC MODEL NUMBER

PM-35XAC1103.5 digit LCD, 2VDC, 120VAC Power

PM-35XACAR13.5 digit LCD, Autoranging, 120VAC Power

Special Options and Accessories

Part Number .Description

► SPECIAL OPTIONS (Specify Inputs & Req. Reading)

VA-200MVF1200mVDC Range Change

VF-0020V20VDC Range Change

VF-0200V200VDC Range Change for 3.5 digit PM Series

VF-1200V1200VDC Range Change for 3.5 digit PM Series

VS-3.5Non-Std Range and Scale - 3.5 Digit PM Meters

► ACCESSORIES



CN-S15Dual Row 15 Pin Edge Connector, Solder Type

SL.CASECLRSlim Bezel Case, Clear Faceplate w/Mtg Hardware

CL.CASECLRCenter Mount Case, Clear Faceplate w/Mtg Hardware

EM.CASECLREnd Mount Case, Clear Faceplate w/Mtg Hardware

Prices subject to change without notice.

WARRANTY

Texmate warrants that its products are free from defects in material and workmanship under normal use and service for a period of one year from date of shipment. Texmate's obligations under this warranty are limited to replacement or repair, at its option, at its factory, of any of the products which shall, within the applicable period after shipment, be returned to Texmate's facility, transportation charges pre-paid, and which are, after examination, disclosed to the satisfaction of Texmate to be thus defective. The warranty shall not apply to any equipment which shall have been repaired or altered, except by Texmate, or which shall have been subjected to misuse, negligence, or accident. In no case shall Texmate's liability exceed the original purchase price. The aforementioned provisions do not extend the original warranty period of any product which has been either repaired or replaced by Texmate.

USER'S RESPONSIBILITY

We are pleased to offer suggestions on the use of our various products either by way of printed matter or through direct contact with our sales/application engineering staff. However, since we have no control over the use of our products once they are shipped, NO WARRANTY WHETHER OF MERCHANTABILITY, FITNESS FOR PURPOSE, OR OTHERWISE is made beyond the repair, replacement, or refund of purchase price at the sole discretion of Texmate. Users shall determine the suitability of the product for the intended application before using, and the users assume all risk and liability whatsoever in connection therewith, regardless of any of our suggestions or statements as to application or construction. In no event shall Texmate's liability, in law or otherwise, be in excess of the purchase price of the product.

Texmate cannot assume responsibility for any circuitry described. No circuit patent or software licenses are implied. Texmate reserves the right to change circuitry, operating software, specifications, and prices without notice at any time.



995 Park Center Drive • Vista, CA 92081-8397

Tel: 1-760-598-9899 • USA 1-800-839-6283 • That's 1-800-TEXMATE

Fax: 1-760-598-9828 • Email: sales@texmate.com • Web: www.texmate.com

Texmate has facilities in Japan, New Zealand, Taiwan, and Thailand. We also have authorized distributors throughout the USA and in 28 other countries.

For product details visit www.texmate.com

Local Distributor Address