



PM-45LBCD Parallel BCD Option for the PM-45L

PM-45LUBCD Parallel BCD Option for the PM-45LU

4.5 Digit Tri-State Buffered Parallel BCD Output Option for the PM-45L and PM-45LU Panel Meters. Also Available as a Field Retrofit Module.



General Features

The Parallel BCD Output Module for use with Texmate's Model PM-45L and PM-45LU Digital Panel Meters is designed to further increase the versatility of the meters. It consists of an additional PC board mounted in the case with the meter connected to it by a flexible ribbon cable.

The Parallel BCD module incorporates CMOS circuitry with tri-state output, capable of two low power TTL loads.

The unit may be used to drive remote displays, digital printers, digital comparators, or to provide data for digital processor applications.

NOTE: This instruction sheet only provides information on the Parallel BCD Output Module. For information on the PM-45L and PM-45LU Digital Panel Meters, see the PM-45L/PM-45LU instruction sheet.

Typical Application Connections

BUS SYSTEM FOR MORE THAN ONE METER USING ONE PRINTER

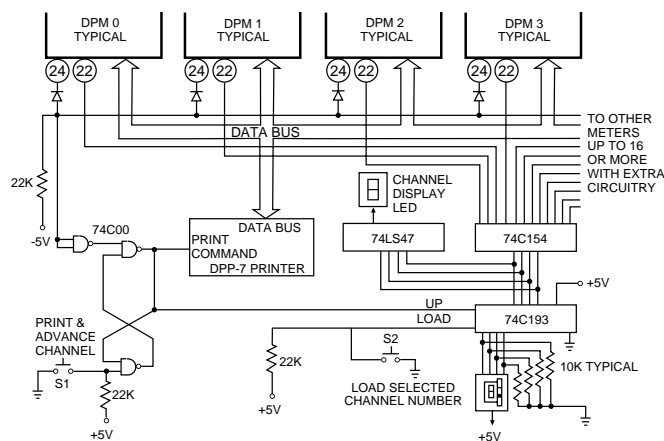

View more application connections and connection instructions on page 3.

PM-Series, high performance versatility for a wide range of applications

PM-35A3.5 digit Red LED, Precision Preference, 2VDC, 5VDC Power
PM-35AR3.5 digit Red LED, Autoranging, 200mV/2VDC, 5VDC Power
PM-35U3.5 digit Red LED, Low Cost, 2VDC, 5VDC Power
PM-35X3.5 digit LCD, Low Power Consumption 2VDC, 5VDC Power
PM-35XAR3.5 digit LCD, Low Power Autoranging
PM-35XAC1103.5 digit LCD, 2VDC, 120VAC Power
PM-35XACAR13.5 digit LCD, Autoranging, 120VAC Power
PM-45L4.5 digit Red LED, Precision Meter w/Differential Input
PM-45LBCDPM-45L w/Tri-State Parallel BCD Output, 5VDC Power
PM-45LMUXBCDPM-45L w/Multiplexed BCD Output

Compatibility

The PM-45LBCD is shipped in a standard Slim Bezel case. The Slim Bezel case is compatible with the CM, SM, TM, & SP Series of meters. The PM-35U can be ordered in End Mount cases for twin mounting or combinations of multiple center mount cases and two end mount cases for stack mounting.

SLIM



BEZEL

Specifications

Input Configuration:	True differential and single-ended
Full Scale Ranges:	±199.99mVDC ±1.9999VDC (standard) ±19.999VDC ±199.99VDC ±1200.0VDC (maximum Input Signal, higher voltages can be measured if voltage dividing resistors are located externally)
Input Impedance:	Exceeds 1000Ω on 200mV and 2V ranges; 10MΩ on all other ranges
Input Protection:	±170VDC or 120VAC on 200mV and 2V ranges; ±1200VDC or 850VAC on all other ranges
Accuracy:	45L: ±(0.01% of reading + 1 digit) ±(0.015% of reading + 2 digits) for 200mV range. 45LU: ±(0.015% of reading + 2 digits) ±(0.02% of reading + 3 digits) for 200mV range.
Temperature Coefficient:	45L: 5PPM/°C in ratiometric, 200PPM/°C using internal adjustable T.C. reference. 45LU: 5PPM/°C ratiometric, 50PPM/°C using internal reference.
Warm Up Time:	10 seconds to specified accuracy
Conversion Rate:	2.5 readings per second
Display:	0.4" LED
Overrange Indication:	When input exceeds full scale on any range being used, most significant "1" digit & polarity symbol are displayed with all other digits blank
Power Requirements:	Low Ripple +4.5 to +5.5VDC at 225mA
Operating Temperature:	0° to +60°C
Storage Temperature:	-20° to +70°C
Relative Humidity	95% (non-condensing)
Case Dimensions:	Bezel 2.76" x 1.17" (69.75 x 29.7mm) Depth behind Bezel 3.32" (84mm) plus 0.68" (17.27mm) for connector.
Weight:88 gms (3.1 oz)

PM-45LU4.5 digit Red LED, Low Cost Meter w/Differential Input
PM-45LUBCDPM-45LU w/Tri-State Parallel BCD Output
PM-45LUMXBCDPM-45LU w/Multiplexed BCD Output
PM-45X4.5 digit LCD, Precision Meter w/Differential Input
PM-45XBCDPM-45X w/Tri-State Parallel BCD Output, 5VDC Power
PM-45XMUXBCDPM-45X w/Multiplexed BCD Output, 5VDC Power
PM-45XU3.5 digit LCD, Low Cost Meter w/Differential Input
PM-45XUBCDPM-45XU w/Tri-State Parallel BCD Output, 5VDC Power
PM-45XUMXBCDPM-45XU w/Multiplexed BCD Output, 5VDC Power

Functional Diagram

The diagram below depicts the function of the parallel BCD output circuit in standard form. The function of the Analog to Digital Converter and the general uses of the DPM are shown on PM-45L/PM-45LU instruction sheet.

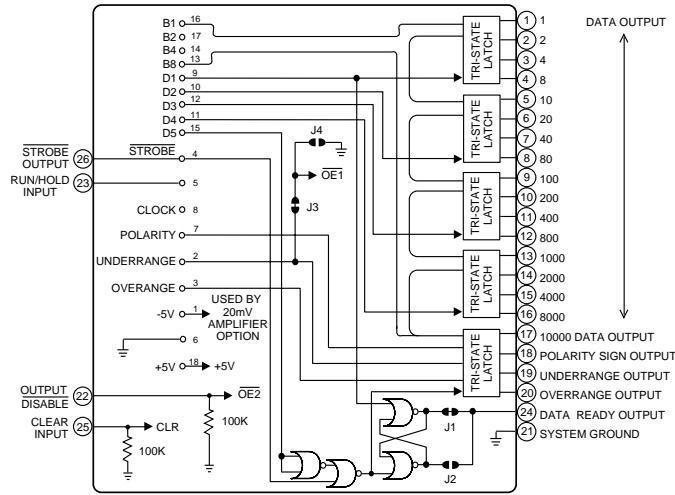

Connector Pinouts

The Texmate Model PM-45LBCD interconnects by means of a standard PC board edge connector having two rows of 13 pins each, on 0.1" centers. A standard 26 pin Ribbon Cable to PCB type connector as shown below is available from Texmate or from almost any connector manufacturer.

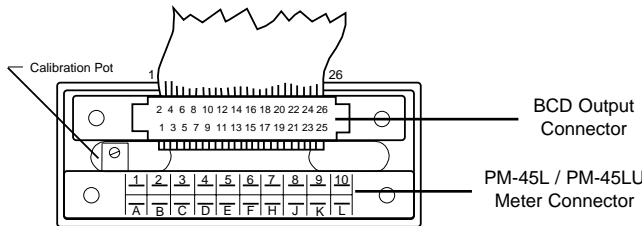

BCD OUTPUT CONNECTOR PINOUTS

Pin 1 - 1 Data Output	Pin 2 - 2 Data Output
Pin 3 - 4 Data Output	Pin 4 - 8 Data Output
Pin 5 - 10 Data Output	Pin 6 - 20 Data Output
Pin 7 - 40 Data Output	Pin 8 - 80 Data Output
Pin 9 - 100 Data Output	Pin 10 - 200 Data Output
Pin 11 - 400 Data Output	Pin 12 - 800 Data Output
Pin 13 - 1000 Data Output	Pin 14 - 2000 Data Output
Pin 15 - 4000 Data Output	Pin 16 - 8000 Data Output
Pin 17 - 10000 Data Output	Pin 18 - Polarity Sign Output
Pin 19 - Underrange Output	Pin 20 - Overage Output
Pin 21 - System Ground	Pin 22 - Output Disable
Pin 23 - Run/Hold Input	Pin 24 - Data Ready Output
Pin 25 - Clear Input	Pin 26 - Strobe Output

NOTE: For PM-45L and PM-45LU connection pinouts see the PM-45L/PM-45LU instruction sheet.

CAUTION: This meter employs high impedance CMOS inputs. Although internal protection has been provided for several hundred volt overloads, the meter will be destroyed if subjected to the high kilovolts of static discharge that can be produced in low humidity environments. Always handle the meter with ground protection.

Pins 1, 2, 3, 4, 5, 6, 7, 8, 9, 10, 11, 12, 13, 14, 15, 16, and 17 - Data Outputs: These pins are latched Tri-state outputs. Data is updated after every conversion cycle. They go to a Tri-state condition (high impedance state) if logic high (+5V) is applied to Output Disable Pin 22. If an overrange condition occurs, a "flashing Zeros" logic output is created as follows: Pins 1 through 16 go to a Tri-state condition (high impedance state) during the autozero and signal integrate phase and to logic low (Logic 0) for the deintegration (reference integrate phase), Pin 17 (MSD data) goes to logic low and remains low until the overrange condition

ceases.

Pin 18 - Polarity Sign Output: Logic high (Logic 1) for positive signal input and logic low (Logic 0) for negative signal input. SEE PIN 22 FOR TRI-STATE OPERATION.

Pin 19 - Underrange Output: Pin 19 is normally logic low (Logic 0). It goes to logic high (Logic 1) for readings between -1800 and +1800 counts (less than 9% of full scale). SEE PIN 22 FOR TRI-STATE OPERATION.

Pin 20 - Overage Output: Pin 20 is normally logic low (Logic 0). It goes to logic high (Logic 1) for readings of more than +19999 or -19999 counts. SEE PIN 22 FOR TRI-STATE OPERATION.

Pin 21 - System Ground: Pin 21 is the common for all digital signals.

Pin 22 - Output Disable: An internal pull-down resistor (100KΩ) maintains Pin 22 at logic low (Logic 0). This enables all the data outputs (Pins 1-20) to operate normally. If logic high (+5V) is applied to Pin 22, all the data outputs (Pins 1-20) will be switched to a Tri-state condition (high impedance state). When operating multiple units on a common bus, Pin 22 is used as the individual control line to each meter. Only the meter with Pin 22 at logic low (Logic 0) will transmit data as all the meters with Pin 22 at logic high (+5V) will be maintained in a Tri-state condition (high impedance state).

Pin 23 - Run/Hold: This pin is a duplicate of Pin 10 on the meter pinout. (See PM-45L/45LU instruction sheet.) If Pin 23 is left open or driven to logic high (Logic 1) by an external controller, the meter will operate in a free-running mode. Under control of the internal 100KHz quartz crystal clock, readings will be updated every 400mS (2.5 per sec.). If Pin 23 is connected to System Ground Pin 21 (or Logic 0), the meter will continue the measurement cycle that it is doing, then latch up and continuously hold the reading obtained as long as Pin 23 is held low. If Pin 23 is released from Pin 21 (Pin 23 then goes logic high) for more than 300ns and returned to Pin 21 (logic low), the meter will complete one conversion, update, and then hold the new reading. For all practical purposes, a manually actuated normally closed pushbutton switch will provide sufficient timing for "press-to-update" operation.

Pin 24 - Data Ready Output: The latched Tri-state outputs (Pins 1-20) provide valid data at all times except during data updating, which commences 101 clock pulses after the end of the full 40,002 count measurement cycle. While data is being updated, Pin 24 normally at logic high (Logic 1) goes to logic low (Logic 0) for 800 clock pulses. A print command can be derived by triggering on the positive going edge of the output of Pin 24. (See timing diagram.)

Pin 25 - Clear Input: An internal pull-down resistor (100KΩ) maintains Pin 25 at logic low (Logic 0) for normal operation. A logic high (Logic 1) input to Pin 25 will clear all the latched Tri-state outputs (Pins 1-20) to logic low (Logic 0).

Pin 26 - Strobe Output: Five Strobe outputs of a half clock pulse width each occur synchronously with the updating of the parallel BCD data latches for each digit. The sequence is Digit 5 (MSD), Digit 4, 3, 2, and 1. Each negative pulse occurs 200 clock counts apart and the five pulses occur only once for each measurement cycle. The output of data ready Pin 24 goes low on the first negative going Strobe pulse and remains low until the last negative Strobe pulse goes low. The Strobe output is normally only used for system checkout. (See timing diagram.)

Component Layout

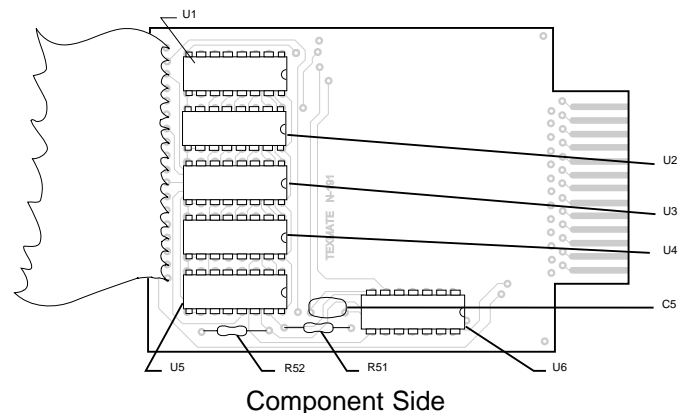

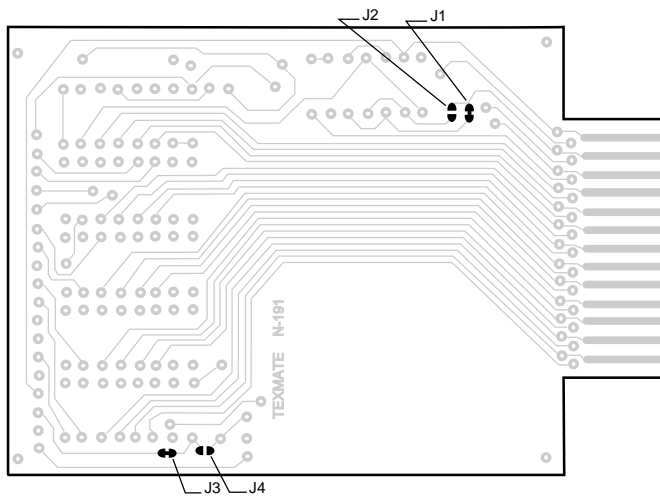

Solder Side

Typical Application Connections

The PM-45LBCD may be used in a wide variety of configurations. The following circuits illustrate some of the possibilities and demonstrate the exceptional versatility of Texmate products. Components called for in the applications which are not part of the standard meter may be supplied by the user or in some cases purchased from Texmate. The circuit diagrams explain the basic pinout connections required for each application. Unless otherwise specified, the diagrams will show the component values and solder junctions that would normally be installed on a standard 2V range meter. For those applications which have alternative ranges and/or input configurations, the required component values and any modifications are described in the text.

Thumbwheel Switch Digital Comparator with High, Low, Equal Output

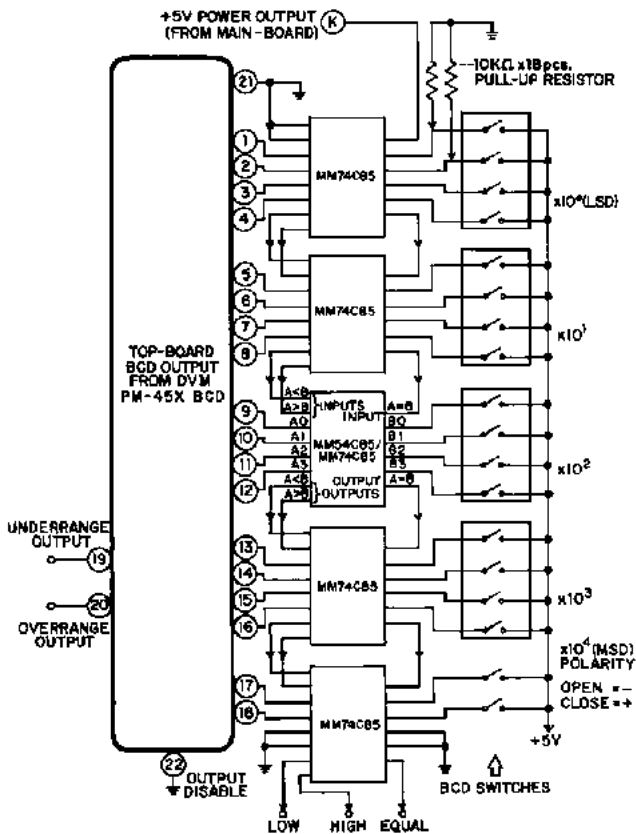

MORE THAN ONE METER COMPARED TO ONE SETPOINT

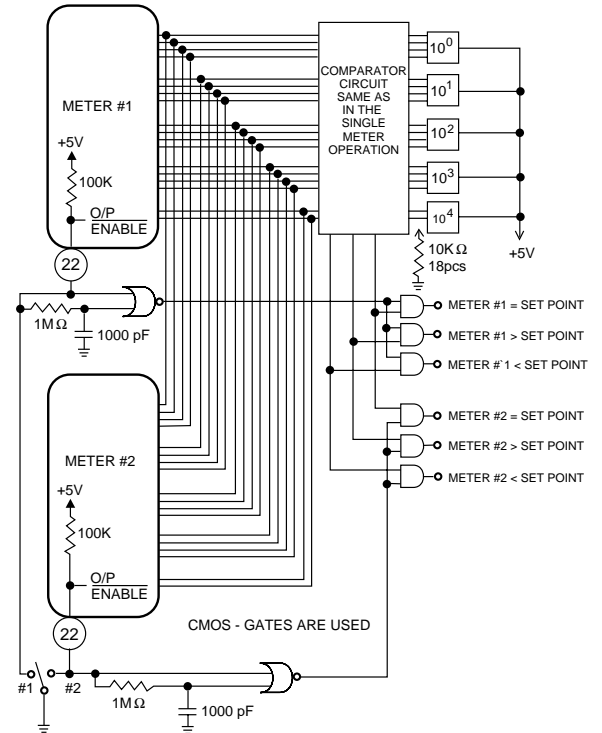

TIMING DIAGRAM

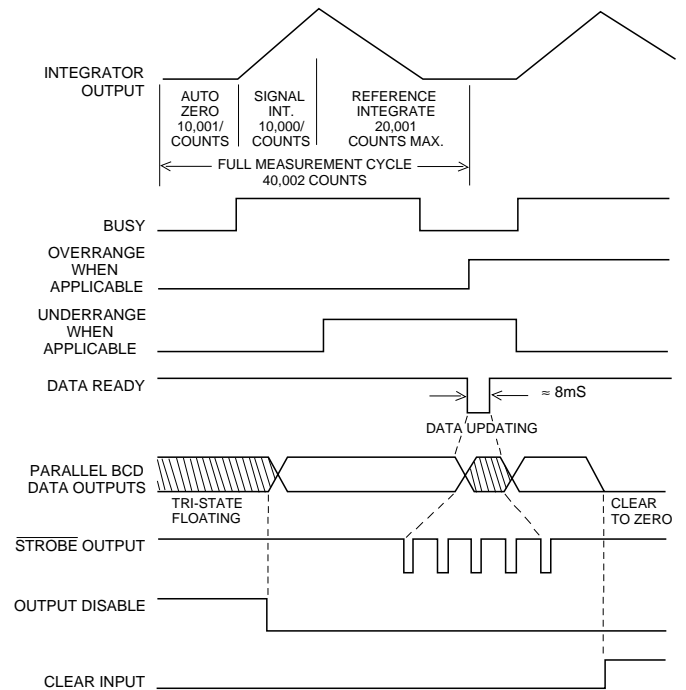

Optional PCB Edge Connector

PCB Edge Connector

A 26-pin edge connector (two rows of 13 pins) to 26 wire ribbon cable is used to connect the PM-BCD Series of meters. Order part no. CN-S13.



PM Case Dimensions and Panel Cutouts

The Slim Bezel Case is supplied as standard. If specified at time of ordering, any combination of Twin Mounting and Multiple Array Cases may be substituted at no additional cost. Extra cases may be ordered separately.

STANDARD SLIM BEZEL CASE

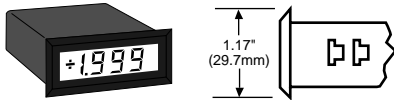

SLIM BEZEL CASE
Standard Black ABS case with matte finish bezel for single unit mounting.

Part No. **SL-CASERED** for LED's
SL-CASECLR for LCD's

OPTIONAL TWIN MOUNTING OR MULTIPLE ARRAY CASES

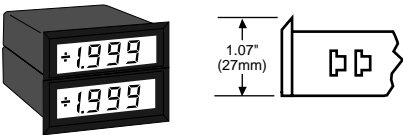

END MOUNT CASE
Same styling as Slim Bezel case but with bottom edge of bezel removed. Two End Mount cases can be twin mounted in a single cutout.

Part No. **EM-CASERED** for LED's
EM-CASECLR for LCD's

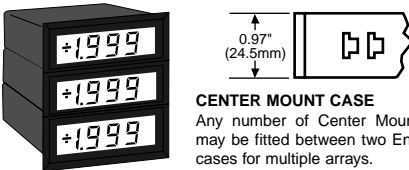

CENTER MOUNT CASE
Any number of Center Mount cases may be fitted between two End Mount cases for multiple arrays.

Part No. **CM-CASERED** for LED's
CM-CASECLR for LCD's

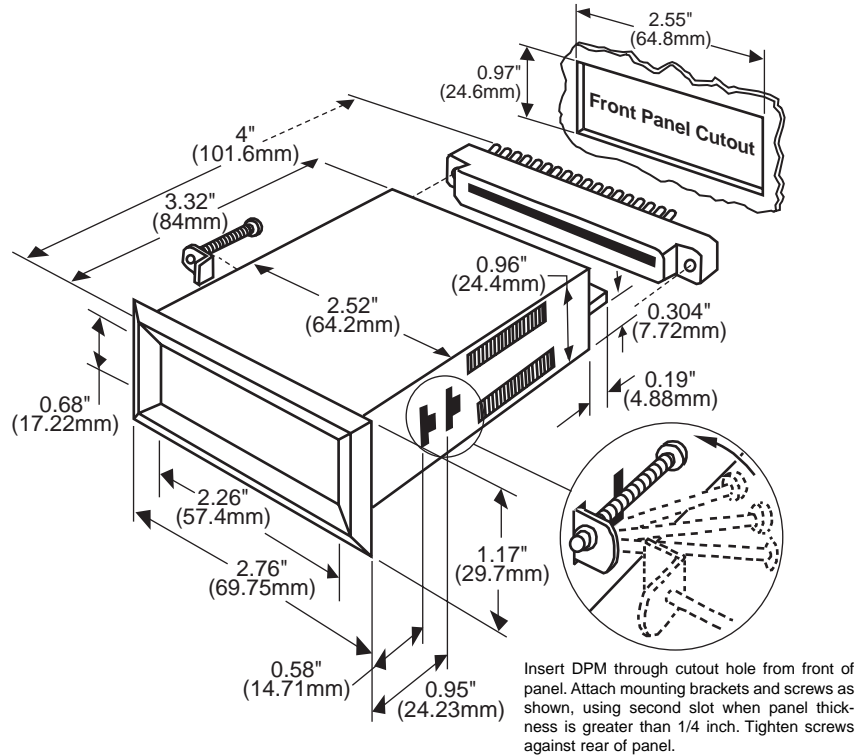

Insert DPM through cutout hole from front of panel. Attach mounting brackets and screws as shown, using second slot when panel thickness is greater than 1/4 inch. Tighten screws against rear of panel.

Ordering Information

Standard Options for this Model Number

Part Number .Description

► BASIC MODEL NUMBER

PM-45LBCD . . .PM-45L w/Tri-State Parallel BCD Output, 5VDC
PM-45LBCDO . . .BCD Output Board for PM-45L
PM-45LUBCD . . .PM-45LU w/Tri-State Parallel BCD Output, 5VDC

Special Options and Accessories

Part Number .Description

► SPECIAL OPTIONS (Specify Inputs & Req. Reading)

VDA-200MVFI . . .200mVDC Range Change

WARRANTY

Texmate warrants that its products are free from defects in material and workmanship under normal use and service for a period of one year from date of shipment. Texmate's obligations under this warranty are limited to replacement or repair, at its option, at its factory, of any of the products which shall, within the applicable period after shipment, be returned to Texmate's facility, transportation charges pre-paid, and which are, after examination, disclosed to the satisfaction of Texmate to be thus defective. The warranty shall not apply to any equipment which shall have been repaired or altered, except by Texmate, or which shall have been subjected to misuse, negligence, or accident. In no case shall Texmate's liability exceed the original purchase price. The aforementioned provisions do not extend the original warranty period of any product which has been either repaired or replaced by Texmate.

VFA-0020V20VDC Range Change for 4.5 digit PM Series
VFA-0200V200VDC Range Change for 4.5 digit PM Series
VFA-1200V1200VDC Range Change for 4.5 digit PM Series
VS-4.5Non-Std Range and Scale - 4.5 Digit PM Meters

► ACCESSORIES

CN-S13Dual Row 13 Pin Conn to 26 Wire Ribbon Cable
SL.CASEREDSlim Bezel Case, Red Faceplate w/Mtg Hardware
CL.CASEREDCenter Mount Case, Red Faceplate w/Mtg Hardware
EM.CASEREDEnd Mount Case, Red Faceplate w/Mtg Hardware

Prices subject to change without notice.

USER'S RESPONSIBILITY

We are pleased to offer suggestions on the use of our various products either by way of printed matter or through direct contact with our sales/application engineering staff. However, since we have no control over the use of our products once they are shipped, NO WARRANTY WHETHER OF MERCHANTABILITY, FITNESS FOR PURPOSE, OR OTHERWISE is made beyond the repair, replacement, or refund of purchase price at the sole discretion of Texmate. Users shall determine the suitability of the product for the intended application before using, and the users assume all risk and liability whatsoever in connection therewith, regardless of any of our suggestions or statements as to application or construction. In no event shall Texmate's liability, in law or otherwise, be in excess of the purchase price of the product.

Texmate cannot assume responsibility for any circuitry described. No circuit patent or software licenses are implied. Texmate reserves the right to change circuitry, operating software, specifications, and prices without notice at any time.

TEXMATE INC

995 Park Center Drive • Vista, CA 92081-8397

Tel: 1-760-598-9899 • USA 1-800-839-6283 • That's 1-800-TEXMATE

Fax: 1-760-598-9828 • Email: sales@texmate.com • Web: www.texmate.com

Texmate has facilities in Japan, New Zealand, Taiwan, and Thailand. We also have authorized distributors throughout the USA and in 28 other countries.

For product details visit www.texmate.com

Local Distributor Address