

1/32 DIN 48x24mm (1.89"x0.95") Case Dimensions and Panel Cutout

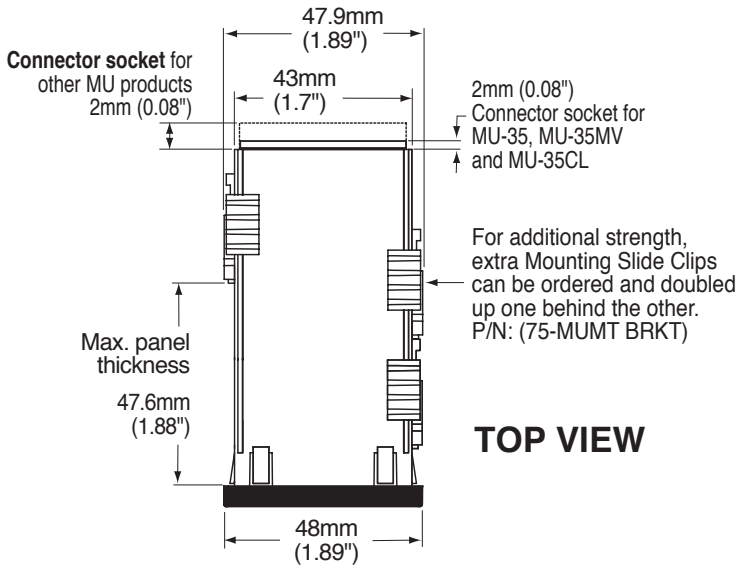

PANEL CUTOUT
Case will mount in standard 1/32 DIN cutouts

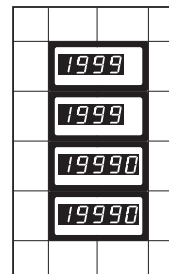
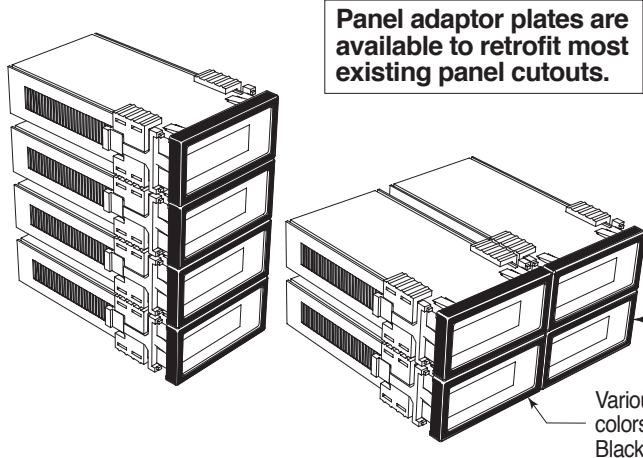
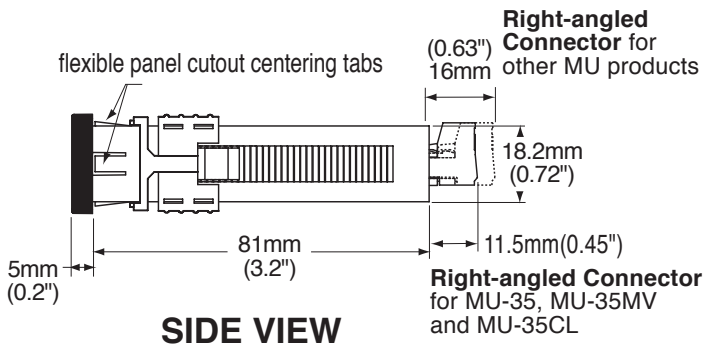
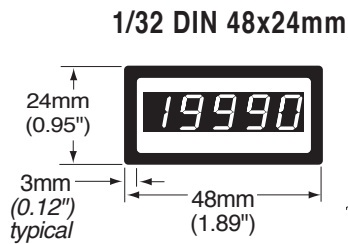
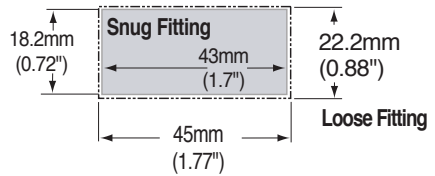

The 48x24mm case is particularly suitable for mounting in mosaic panels or insulative panels up to 2" thick. They can also stack mount, 2 up in existing cutouts for 1/16 DIN (48x48mm) or 4 up in 1/8 DIN (48x96mm).