



PM-35A

5 Optional DC Input Ranges
from 200mV to 1200V
3 1/2 DIGIT with 0.56" LEDs
in a Slim Bezel Case

A Precision Low Cost General Purpose Differential Input Meter.

General Features

The PM-35A is a popular, general purpose 5VDC powered instrument. More than 60,000 units have been installed throughout the world in thousands of different applications, attesting to the meter's utility and reliability. A single CMOS/LSI dual slope autozeroing analog to digital converter is used and the unit measures true differential for single-ended DC voltages over five user programmable ranges from $\pm 199.9\text{mV}$ to $\pm 1200\text{V}$ full scale. Provision has been made for many user selectable operating modes, including a current meter, ratiometric ohm-meter, and a temperature meter.

An on board DC to DC converter provides up to 10mA of auxiliary power for external user circuitry.

The differential input capability of the PM-35A is particularly useful for making accurate measurements of very small signals in the presence of much larger common mode signals. The PM-35A is ideal for measuring various balanced transducers and bridge inputs and long term drift of the excitation voltage can be compensated for by using the external reference differential ratiometric mode of operation.

Typical Application Connections

SINGLE ENDED METER: 200MV Range, <2V Range For 200mV Range: 1) Omit R1 and R2; 2) Change R6 from 470k Ω to 47k Ω ; 3) Change R8 from 619 Ω to 121 Ω ; 4) Change R9 from 4.32k Ω to 12.1k Ω ; 5) Change C4 from 0.47 μF to 0.33 μF ; 6) Change C7 from 0.1 μF to 2.2 μF .

For <2V Range: 1) Install R1 and R2 as specified under section titled Useful Tables.

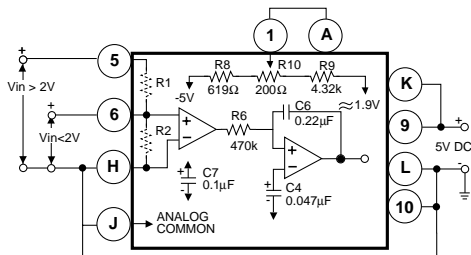

View more application connections and connection instructions on page 3.

Compatibility

The PM-35A is shipped in a standard Slim Bezel case. The Slim Bezel case is compatible with the CM, SM, TM, & SP Series of meters. The PM-35U can be ordered in End Mount cases for twin mounting or combinations of multiple center mount cases and two end mount cases for stack mounting.

SLIM



BEZEL

Specifications

- Input Configuration:**..... True differential and single-ended
- Full Scale Ranges:** $\pm 199.9\text{mVDC}$
 $\pm 1.999\text{VDC}$ (standard)
 $\pm 19.99\text{VDC}$
 $\pm 199.9\text{VDC}$
 $\pm 1200\text{VDC}$
- Input Impedance:** Exceeds 1000M Ω on 200mV and 2V ranges; 10M Ω on all other ranges
- Input Protection:**..... $\pm 500\text{VDC}$ or 350VAC maximum on 200mV and 2V ranges; $\pm 1200\text{VDC}$ or 850VAC on all other ranges
- Accuracy:** $\pm(0.05\%$ of reading + 1 digit)
- Temperature Coefficient:** 5PPM/ $^{\circ}\text{C}$ in ratiometric operation; 50 PPM/ $^{\circ}\text{C}$ Typ. using internal reference on 200mV and 2V ranges
- Warm Up Time:** 10 seconds to specified accuracy
- Conversion Rate:** 3 readings per second nominal
- Display:** 0.56" LED
- Decimal Selection:** User programmable to 4 positions
- Overrange Indication:** ..When input exceeds full scale on any range being used, most significant "1" digit & polarity symbol are displayed with all other digits blank
- Power Requirements:**..... +4.5 to +5.5VDC at 200mA
- Operating Temperature:** 0° to $+60^{\circ}\text{C}$
- Storage Temperature:**..... -20° to $+70^{\circ}\text{C}$
- Relative Humidity** 95% (non-condensing)
- Case Dimensions:** Bezel 2.76" x 1.17" (69.75 x 29.7mm)
 Depth behind Bezel 3.32"(84mm) plus 0.68" (17.27mm) for connector.
- Weight:** 88 gms (3.1 oz)

PM-Series, high performance versatility for a wide range of applications

PM-35A.....3.5 digit Red LED, Precision Preference, 2VDC, 5VDC Power
 PM-35AR3.5 digit Red LED, Autoranging, 200mV/2VDC, 5VDC Power
 PM-35U3.5 digit Red LED, Low Cost, 2VDC, 5VDC Power
 PM-35X.....3.5 digit LCD, Low Power Consumption 2VDC, 5VDC Power
 PM-35XAR3.5 digit LCD, Low Power Autoranging
 PM-35XAC1103.5 digit LCD, 2VDC, 120VAC Power
 PM-35XACAR13.5 digit LCD, Autoranging, 120VAC Power
 PM-45L.....4.5 digit Red LED, Precision Meter w/Differential Input
 PM-45LBCDPM-45L w/Tri-State Parallel BCD Output, 5VDC Power
 PM-45LMUXBCDPM-45L w/Multiplexed BCD Output

PM-45LU4.5 digit Red LED, Low Cost Meter w/Differential Input
 PM-45LUBCDPM-45LU w/Tri-State Parallel BCD Output
 PM-45LUMXBCDPM-45LU w/Multiplexed BCD Output
 PM-45X.....4.5 digit LCD, Precision Meter w/Differential Input
 PM-45XBCDPM-45X w/Tri-State Parallel BCD Output, 5VDC Power
 PM-45XMUXBCDPM-45X w/Multiplexed BCD Output, 5VDC Power
 PM-45XU3.5 digit LCD, Low Cost Meter w/Differential Input
 PM-45XUBCDPM-45XU w/Tri-State Parallel BCD Output, 5VDC Power
 PM-45XUMXBCDPM-45XU w/Multiplexed BCD Output, 5VDC Power

Functional Diagram

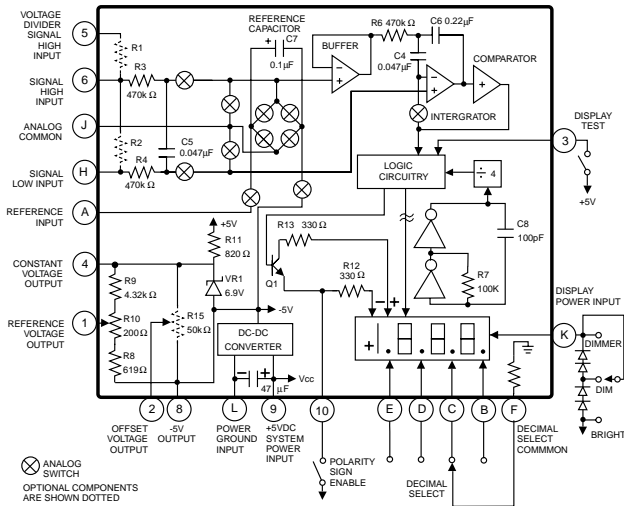

Connector Pinouts

The Texmate Model PM-35A interconnects by means of a standard PC board edge connector having two rows of 10 pins, spaced on 0.156" centers. Connectors are available from Texmate, or from almost any connector manufacturer.

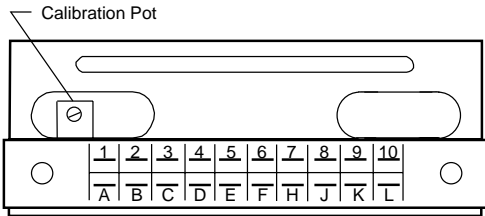

Component Side	Solder Side
REFERENCE VOLTAGE OUTPUT 1	A REFERENCE INPUT
OFFSET VOLTAGE OUTPUT 2	B DECIMAL SELECT (1XXX.)
DISPLAY TEST 3	C DECIMAL SELECT (1XX.X)
CONSTANT VOLTAGE OUTPUT 4	D DECIMAL SELECT (1X.XX)
VOLTAGE DIVIDER SIGNAL HIGH INPUT 5	E DECIMAL SELECT (1.XXX)
SIGNAL HIGH INPUT 6	F DECIMAL SELECT COMMON
NO CONNECTION 7	H SIGNAL LOW INPUT
-5V OUTPUT 8	J ANALOG COMMON
+5VDC SYSTEM POWER INPUT 9	K DISPLAY POWER INPUT
POLARITY SIGN ENABLE 10	L POWER GROUND INPUT

CAUTION: This meter employs high impedance CMOS inputs. Although internal protection has been provided for several hundred volt overloads, the meter will be destroyed if subjected to the high kilovolts of static discharge that can be produced in low humidity environments. Always handle the meter with ground protection.

Pin A - Reference Input: Reference voltage input for A to D converter. Normally supplied from Pin 1. An external reference source referred to Pin 8 may be used instead. Pin 1 may be used as an input for ratiometric measurements. Minimum usable voltage is 0.05VDC, with a maximum voltage of 5.0V. For ratiometric operation, displayed reading = 1000 X (Signal Input Voltage ÷ Reference Input Voltage). The maximum signal input voltage is 5V. Higher voltages must be scaled down through voltage divider. Reference input voltage must remain stable during measurement period. **CAUTION:** Since Pin 8 is floating at -5V the low side of the external reference source must be isolated from the 5V power ground of the meter (Power Ground Input Pin L).

Pins B, C, D, and E - Decimal Select: Decimal points may be displayed as required by connecting the appropriate pin to Decimal Select Common Pin F. The internal current limiting resistor on Pin F is designed to enable only one decimal point. If more than one decimal point is enabled simultaneously their light output will be reduced. **Caution:** Do not connect any Decimal Select Pin directly to Power Ground Input Pin L as the excessive current will destroy the LED in the decimal point display.

Pin F - Decimal Select Common: Decimal points are displayed as required by connecting Pin F to the appropriate Decimal Select Pins B,C,D, or E.

Pin H - Signal Low Input: Signal low input of A to D converter. Maximum over-voltage protection is ±500VDC or 350VAC.

Pin J - Analog Common: This the floating common for the analog section which is normally +2.2V above Power Ground Input Pin L. Pin J may be left floating or it may be connected to power Ground Input Pin L without overloading. When Pin J is tied to Pin L, the common-mode voltage (CMV) of the A/D converter is reduced, which can improve the performance of the meter in some configurations such as the case with Single-Ended inputs.

Pin K - Display Power Input: Power input for LED display drive. For normal operation, connect directly to +5VDC System Power Input Pin 9. Display may be blanked or dimmed by reducing or removing voltage between Pin 9 and Pin K. The power supply to the A to D converter and logic circuits is independent to that of the display. When operated in a power conserving "press-to-read" mode, the reading is instantaneously displayed without any settling time.

Pin L - Power Ground Input: Negative terminal of +5VDC power should be connected to Pin L. All digital signals should be returned to this ground point. Pin L is not internally connected to Analog Common Pin J.

Pin 1 - Reference Voltage Output: Internal precision voltage reference. Standard output is 1.000V, adjustable by ±5% with R10 potentiometer. Usable voltages from 0.05V to 5.0V for special high impedance scaling can be obtained by changing the value of internal dividing resistors R8 and R9. It should be noted that Pin 1 is +1.0V referred to -5V Output Pin 8, or Pin 1 is -4.0V referred to Power Ground Input Pin L.

Pin 2 - Offset Voltage Output: -5V to +1.9V is available with the addition of 3/4" 50k ohms potentiometer in the R15 position on the PC board. It is referred to -5V Output Pin 8. An example is shown in the thermometer application drawing.

Pin 3 - Display Test: All display segments will operate when Pin 3 is connected to +5VDC System Power Input Pin 9.

Pin 4 - Constant Voltage Output: Pin 4 is 6.9V referred to -5V Output Pin 8. The offset voltage and reference voltage are both generated internally from the constant voltage available at Pin 4.

Pin 5 - Voltage Divider Signal High Input: Signal high input for voltage that require attenuation or scaling. Dividing resistors R1 and R2 may be mounted internally for voltages up to 1200V max. Matched dividing resistors for 20V (1/10), 200V (1/100), and 1200V (1/1000) ranges are available from Texmate. Shunt resistors for current measurements up to 200mA may be internally mounted in the R2 position. The current loop input is then applied to Signal High Input Pin 6 and returned through Signal Low Input Pin H.

Pin 6 - Signal High Input: Signal high input of A to D converter. Maximum over-voltage protection is ±500VDC or 350VAC.

Pin 7 - No Connection: This connection pin goes to a unused PCB pad which may be used to mount optional components.

Pin 8 - -5V Output: Auxiliary -5V power output (10mA max.) produced by an internal DC to DC converter. Pin 8 can be also used as a point of reference for calibration purposes.

Pin 9 - +5VDC System Power Input: The meter requires regulated (±10%) 5VDC power at approximately 200mA, depending on the display brightness.

Pin 10 - Polarity Sign Enable: Connect Pin 10 to Power Ground Input Pin L (or apply logic "0") to display plus and minus polarity signs. Leave open (or apply logic "1") to blank.

Component Layout

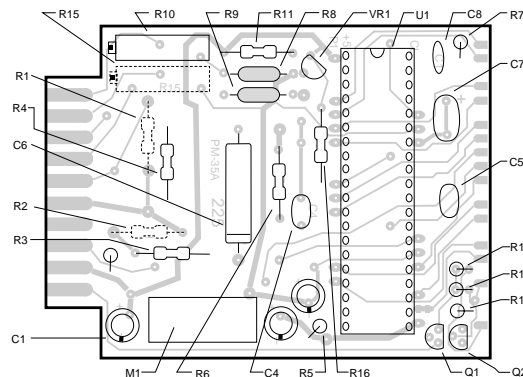

Signal Conditioning Components

SPAN **SPAN Potentiometer (Pot)**
The SPAN pot is on the right side of the display. Typical adjustment is 20% of the input signal range.



ZERO **ZERO Potentiometer (Pot) optional**
The ZERO pot is on the right side of the SPAN Pot. Typically it enables the displayed reading to be offset ±500 counts.

Calibration Procedure

Apply power to the meter. Then, with a precision DC reference source, apply +1.900VDC between the Signal High Input Pin 6 and the Signal Low Input Pin H connected to Power Ground Input L. Adjust R10 potentiometer (on left side as viewed from rear) until the display reads +1.900V. Note: The voltage applied in this case is for a ±1.999V F.S. meter. For other ranges, the voltage applied should be similarly proportionate to the particular full scale voltage.

Typical Application Connections

The PM-35A may be used in a wide variety of configurations. The following circuits illustrate some of the possibilities and demonstrate the exceptional versatility of Texmate products. Components called for in the applications which are not part of the standard meter may be supplied by the user or in some cases purchased from Texmate. The circuit diagrams explain the basic pinout connections required for each application. Unless otherwise specified, the diagrams will show the component values and solder junctions that would normally be installed on a standard 2V range meter. For those applications which have alternative ranges and/or input configurations, the required component values and any modifications are described in the text.

NOTE: Use of these application circuits is entirely at the risk and responsibility of the user and any user modification of the meter may at the discretion of Texmate, void the warranty. (See rear page for user's responsibility and warranty details) The following legend applies to all application circuits: 1) optional component positions are shown in dotted lines; 2) internal solder junctions are shown by  for a closed junction or  for an open junction; 3) calibration voltages as measured by an external user supplied voltmeter are shown by 

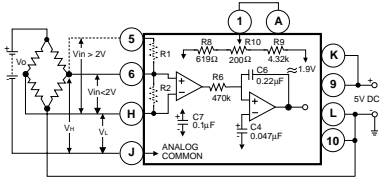

DIFFERENTIAL METER: 200mV Range, >2V Range For 200mV Range: 1) Omit R1 and R2; 2) Change R6 from 470kΩ to 47kΩ; 3) Change R8 from 619Ω to 121Ω; 4) Change R9 from 4.3kΩ to 12.1kΩ; 5) Change C4 from 0.047μF to 0.33μF; 6) Change C7 from 0.1μF to 2.2μF.

For >2V Range: 1) Install R1 and R2 as specified under section titled Useful Tables.

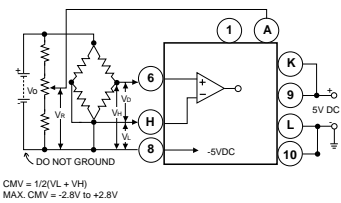

DIFFERENTIAL METER WITH EXTERNAL REFERENCE NOTE: Since Pin 8 and Pin L are not at the same potential, either the +5V System Power Supply or the bridge excitation voltage V_0 should be isolated. The CMV is +2V to +8V referred to Pin 8.

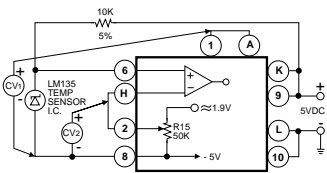

TEMPERATURE METER WITH ZERO OFFSET 1) Install R15, minimum of 20kΩ maximum of 100kΩ; 2) Adjust R10 until $C_{V1}=1.000V$; Adjust R15 until $C_{V2}=2.732V$ for $-50.0^{\circ}C$ to $+150.0^{\circ}C$. Special scaling is required for $^{\circ}F$.

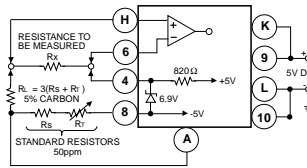

DIFFERENTIAL RATIOMETRIC OHMMETER 1) Install R_s and R_T specified under section titled Useful Tables; 2) Install R_L with a value equal to $3 \times (R_s + R_T)$ for use as a current limiting resistor. **NOTE:** F.S. Range = $(R_s + R_T) \times 2$, and Displayed Reading = $R_x \div (R_s + R_T) \times 1000$. R_x is device under measurement.

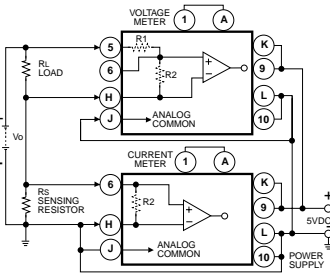

SIMULTANEOUS VOLTAGE & CURRENT MEASUREMENT

1) Connect Current Meter as for 200mV voltmeter for minimum drop on R_s or R_2 . Use R_s externally for currents greater than 200mA; 2) Install R_1 , R_2 , and R_3 as specified under section titled Useful Tables. **NOTE:** R_s must be located in low side of current loop, and Signal Low Input Pin H of Voltage Meter must not be grounded. If it is necessary to install R_s on the high side of the current loop, the Current Meter must be operated from an isolated power supply.

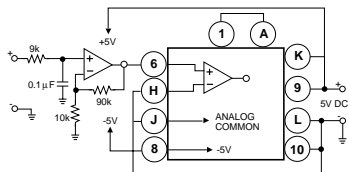

AUXILIARY POWER OUTPUT

+5V output for external OPAMP circuitry, 10mA max.

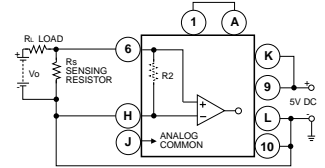

SINGLE ENDED CURRENT METER

1) Connect meter as for 200mV voltmeter; 2) Install R_s . **NOTE:** R_s must be externally mounted when F.S. current is greater than 200mA, and 4-wire type connection should be used. For currents of 200mA F.S. or less, R_s may be internally mounted in the R2 position. Standard values for R_s are specified under section titled Useful Tables.

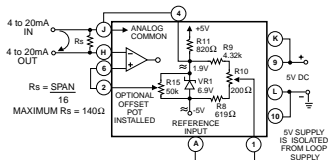

4 TO 20mA RECEIVER

1) Connect up the circuit as shown; 2) Install $R_s = \text{SPAN} \div 16$ on the connector, external to the meter. The max. span allowed is 2240 counts; 3) Adjust R15 to get the required reading for a 4mA input; 4) Adjust R10 to get the required reading for a 20mA input; 5) Repeat steps 3 and 4 until the readings stabilize. **NOTE:** The meter should be powered by an isolated 5V DC power supply.

Useful Tables

VOLTAGE RANGE CHANGE

F.S. In	R1	R2	Resolution
200mV	omit	omit	100μV
2V	omit	omit	1mV
20V	9M	1M	10mV
200V	10M	100k	100mV
1200V	10M	10k	1V

CURRENT RANGE CHANGE (*)

Use 200mV F.S. meter for minimum voltage drop.

F.S. In	R_s External	Resolution
20A	0.01	10mA
2A	0.1	1mA
F.S. In	R_s Internal	Resolution
200mA	1	100μA
20mA	10	10μA
2mA	100	1μA
200μA	1k	100nA

OHMMETER RANGE CHANGE

F.S. In	R_s+R_T	Resolution
200	100	100m
2k	1k	1
20k	10k	10
200k	100k	100
2M	1M	1k
20M	10M	10k

PM Case Dimensions and Panel Cutouts

The Slim Bezel Case is supplied as standard. If specified at time of ordering, any combination of Twin Mounting and Multiple Array Cases may be substituted at no additional cost. Extra cases may be ordered separately.

STANDARD SLIM BEZEL CASE

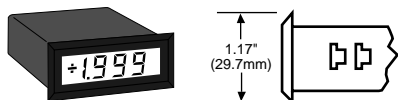

SLIM BEZEL CASE
Standard Black ABS case with matte finish bezel for single unit mounting.

Part No. **SL-CASERED** for LED's
SL-CASECLR for LCD's

OPTIONAL TWIN MOUNTING OR MULTIPLE ARRAY CASES

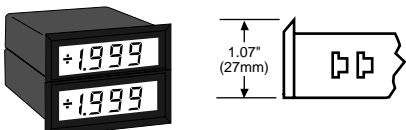

END MOUNT CASE
Same styling as Slim Bezel case but with bottom edge of bezel removed. Two End Mount cases can be twin mounted in a single cutout.

Part No. **EM-CASERED** for LED's
EM-CASECLR for LCD's

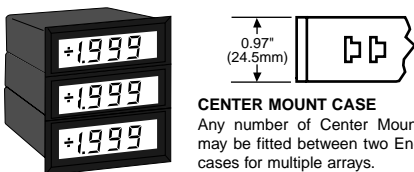

CENTER MOUNT CASE
Any number of Center Mount cases may be fitted between two End Mount cases for multiple arrays.

Part No. **CM-CASERED** for LED's
CM-CASECLR for LCD's

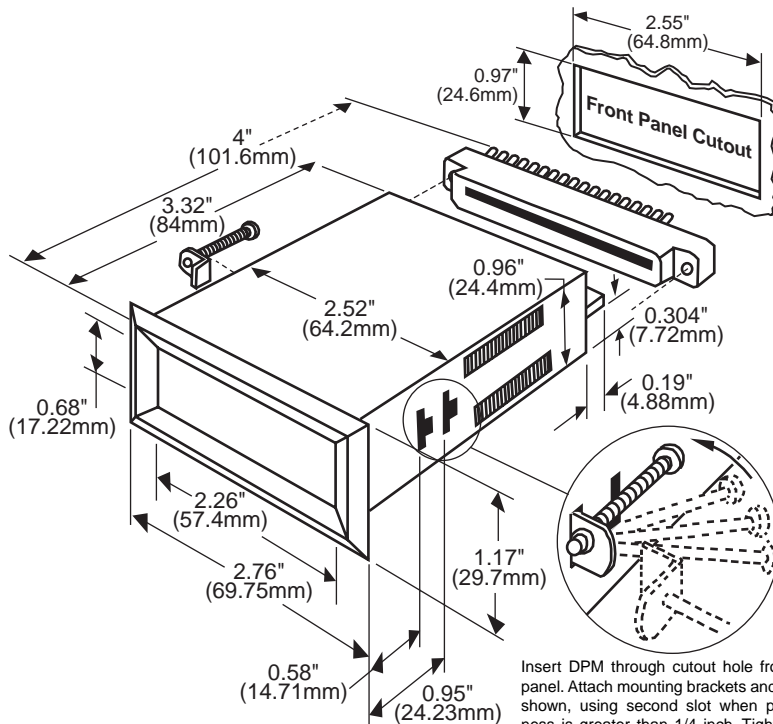

Insert DPM through cutout hole from front of panel. Attach mounting brackets and screws as shown, using second slot when panel thickness is greater than 1/4 inch. Tighten screws against rear of panel.

Ordering Information

Standard Options for this Model Number

Part Number .Description

► BASIC MODEL NUMBER

PM-35A3.5 digit Red LED, Precision Preference, 2VDC, 5VDC pwr

Special Options and Accessories

Part Number .Description

► SPECIAL OPTIONS (Specify Inputs & Req. Reading)

VA-200MVFI200mVDC Range Change

VF-0020V20VDC Range Change

VF-0200V200VDC Range Change for 3.5 digit PM Series
VF-1200V1200VDC Range Change for 3.5 digit PM Series
VS-3.5Non-Std Range and Scale - 3.5 Digit PM Meters

► ACCESSORIES



CN-L10Dual Row 10 Pin Connector, Solder Type
SL.CASERED . . . Slim Bezel Case, Red Faceplate w/Mtg Hardware
CL.CASERED . . .Center Mount Case, Red Faceplate w/Mtg Hardware
EM.CASERED . . .End Mount Case, Red Faceplate w/Mtg Hardware

Prices subject to change without notice.

WARRANTY

Texmate warrants that its products are free from defects in material and workmanship under normal use and service for a period of one year from date of shipment. Texmate's obligations under this warranty are limited to replacement or repair, at its option, at its factory, of any of the products which shall, within the applicable period after shipment, be returned to Texmate's facility, transportation charges pre-paid, and which are, after examination, disclosed to the satisfaction of Texmate to be thus defective. The warranty shall not apply to any equipment which shall have been repaired or altered, except by Texmate, or which shall have been subjected to misuse, negligence, or accident. In no case shall Texmate's liability exceed the original purchase price. The aforementioned provisions do not extend the original warranty period of any product which has been either repaired or replaced by Texmate.

USER'S RESPONSIBILITY

We are pleased to offer suggestions on the use of our various products either by way of printed matter or through direct contact with our sales/application engineering staff. However, since we have no control over the use of our products once they are shipped, NO WARRANTY WHETHER OF MERCHANTABILITY, FITNESS FOR PURPOSE, OR OTHERWISE is made beyond the repair, replacement, or refund of purchase price at the sole discretion of Texmate. Users shall determine the suitability of the product for the intended application before using, and the users assume all risk and liability whatsoever in connection therewith, regardless of any of our suggestions or statements as to application or construction. In no event shall Texmate's liability, in law or otherwise, be in excess of the purchase price of the product.

Texmate cannot assume responsibility for any circuitry described. No circuit patent or software licenses are implied. Texmate reserves the right to change circuitry, operating software, specifications, and prices without notice at any time.

TEXMATE INC

995 Park Center Drive • Vista, CA 92081-8397

Tel: 1-760-598-9899 • USA 1-800-839-6283 • That's 1-800-TEXMATE

Fax: 1-760-598-9828 • Email: sales@texmate.com • Web: www.texmate.com

Texmate has facilities in Japan, New Zealand, Taiwan, and Thailand. We also have authorized distributors throughout the USA and in 28 other countries.

For product details visit www.texmate.com

Local Distributor Address

Copyright © 2003 Texmate Inc. All Rights Reserved.