



PM-45L Precision Panel Meter PM-45LU

Low Cost Meter w/Differential Input
Both have 4 1/2 DIGIT with .4" LED
in a Slim Bezel Case

High Accuracy LED Meters with 10mV Resolution, True Differential Inputs and Standard MUX-BCD or Optional Parallel BCD Outputs

General Features

The PM-45L and PM-45LU are truly unique and extremely versatile instruments. They offer more high performance features than most larger and more expensive DPM's.

Both meters incorporate a crystal controlled 100KHz clock that provides an exceptionally high normal mode rejection of 120dB at multiples of 50/60Hz. Bipolar differential and single-ended DC voltages from $\pm 199.99\text{mV}$ to $\pm 1200.0\text{V}$ full scale can be measured and scaled in almost any known engineering unit. Provision has been made for signal offsetting and the capability of attenuating both high and low signal inputs. Resolution is $10\mu\text{V}$ over ± 19999 counts, and errors due to zero drift are virtually eliminated by autozeroing. Other modes of operation, selectable by the user, include an ohmmeter mode, current meter mode and ratiometric mode.

Multiplexed BCD data is available internally from a row of auxiliary solder pads. Both meters may be ordered with an internally mounted Tri-state Buffered Parallel BCD Output Board. This option, which is described in detail on a separate data sheet, can also be purchased for field retrofit.

Typical Application Connections

SINGLE-ENDED METER - <2V RANGE

1) Standard 2V Full Scale Range single-ended voltmeter is shown. R1A and R1B are shorted by jumpers and R2A and R2B are not installed. 2) Connect Pin 3 to the nearest end of the signal source ground to avoid possible errors caused by ground loop currents.

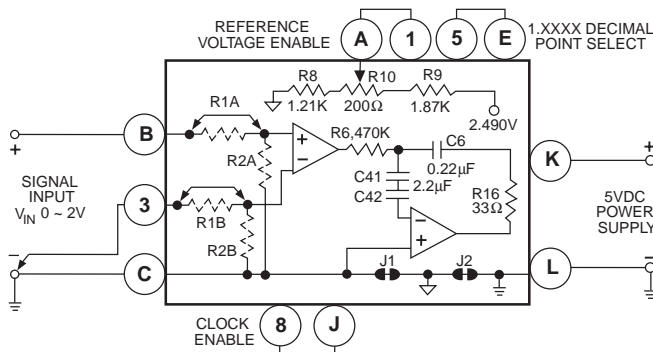

View more application connections and connection instructions on page 3.

PM-Series, high performance versatility for a wide range of applications

PM-35A.....	3.5 digit Red LED, Precision Preference, 2VDC, 5VDC Power
PM-35AR	3.5 digit Red LED, Autoranging, 200mV/2VDC, 5VDC Power
PM-35U	3.5 digit Red LED, Low Cost, 2VDC, 5VDC Power
PM-35X.....	3.5 digit LCD, Low Power Consumption 2VDC, 5VDC Power
PM-35XAR	3.5 digit LCD, Low Power Autoranging
PM-35XAC110	3.5 digit LCD, 2VDC, 120VAC Power
PM-35XACAR1	3.5 digit LCD, Autoranging, 120VAC Power
PM-45L.....	4.5 digit Red LED, Precision Meter w/Differential Input
PM-45LBCD	PM-45L w/Tri-State Parallel BCD Output, 5VDC Power
PM-45LMUXBCD	PM-45L w/Multiplexed BCD Output

Compatibility

The PM-45L is shipped in a standard Slim Bezel case. The Slim Bezel case is compatible with the CM, SM, TM, & SP Series of meters. The PM-35U can be ordered in End Mount cases for twin mounting or combinations of multiple center mount cases and two end mount cases for stack mounting.

SLIM



BEZEL

Specifications

Input Configuration:	True differential and single-ended
Full Scale Ranges:	$\pm 199.99\text{mVDC}$ $\pm 1.9999\text{VDC}$ (standard) $\pm 19.999\text{VDC}$ $\pm 199.99\text{VDC}$ $\pm 1200.0\text{VDC}$ (maximum Input Signal, higher voltages can be measured if voltage dividing resistors are located externally)
Input Impedance:	Exceeds 1000Ω on 200mV and 2V ranges; $10\text{M}\Omega$ on all other ranges
Input Protection:	$\pm 170\text{VDC}$ or 120VAC on 200mV and 2V ranges; $\pm 1200\text{VDC}$ or 850VAC on all other ranges
Accuracy:	45L: $\pm(0.01\%$ of reading + 1 digit) $\pm(0.015\%$ of reading + 2 digits) for 200mV range. 45LU: $\pm(0.015\%$ of reading + 2 digits) $\pm(0.02\%$ of reading + 3 digits) for 200mV range.
Temperature Coefficient: ..	45L: 5PPM/ $^{\circ}\text{C}$ in ratiometric, 200PPM/ $^{\circ}\text{C}$ using internal adjustable T.C. reference. 45LU: 5PPM/ $^{\circ}\text{C}$ ratiometric, 50PPM/ $^{\circ}\text{C}$ using internal reference.
Warm Up Time:	10 seconds to specified accuracy
Conversion Rate:	2.5 readings per second
Display:	0.4" LED
Overrange Indication: ..	When input exceeds full scale on any range being used, most significant "1" digit & polarity symbol are displayed with all other digits blank
Power Requirements:	Low Ripple +4.5 to +5.5VDC at 225mA
Operating Temperature:	0° to $+60^{\circ}\text{C}$
Storage Temperature:	-20° to $+70^{\circ}\text{C}$
Relative Humidity	95% (non-condensing)
Case Dimensions:	Bezel 2.76" x 1.17" (69.75 x 29.7mm) Depth behind Bezel 3.32" (84mm) plus 0.68" (17.27mm) for connector.
Weight:88 gms (3.1 oz)

PM-45LU	4.5 digit Red LED, Low Cost Meter w/Differential Input
PM-45LBCD	PM-45LU w/Tri-State Parallel BCD Output
PM-45LMUXBCD	PM-45LU w/Multiplexed BCD Output
PM-45X.....	4.5 digit LCD, Precision Meter w/Differential Input
PM-45XBCD	PM-45X w/Tri-State Parallel BCD Output, 5VDC Power
PM-45XMUXBCD	PM-45X w/Multiplexed BCD Output, 5VDC Power
PM-45XU	3.5 digit LCD, Low Cost Meter w/Differential Input
PM-45XUBCD	PM-45XU w/Tri-State Parallel BCD Output, 5VDC Power
PM-45XUMUXBCD	PM-45XU w/Multiplexed BCD Output, 5VDC Power

Functional Diagram

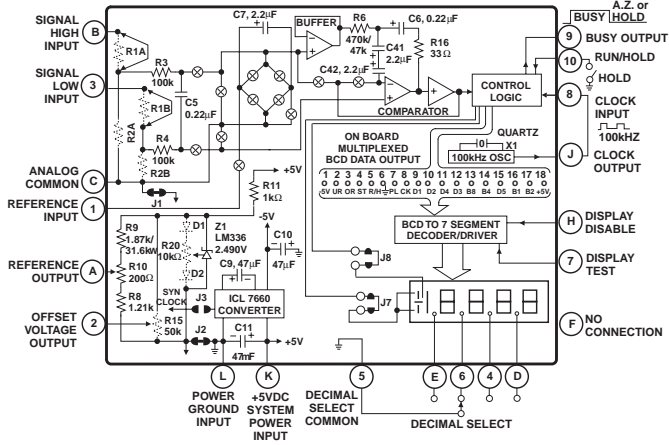

Connector Pinouts

The Texmate Model PM-45L/PM-45LU is interconnected by means of a standard PC board edge connector having two rows of 10 pins, spaced on 0.156" centers. The optional parallel BCD Output is interconnected by a standard PC board edge connector having two rows of 13 pins spaced 0.1" centers. (A standard 26 pin, PCB to Ribbon Cable Connector is recommended.) Connectors are available from Texmate, or from almost any connector manufacturer.

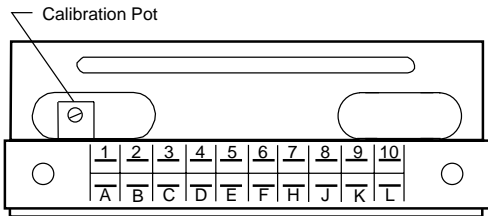

Component Side	Solder Side
REFERENCE INPUT 1	A REFERENCE OUTPUT
OFFSET VOLTAGE OUTPUT 2	B SIGNAL HIGH INPUT
SIGNAL LOW INPUT 3	C ANALOG COMMON
DECIMAL SELECT (1XX.XX) 4	D DECIMAL SELECT (1XXX.X)
DECIMAL SELECT COMMON 5	E DECIMAL SELECT (1.XXXX)
DECIMAL SELECT (1X.XXX) 6	F NO CONNECTION
DISPLAY TEST 7	H DISPLAY DISABLE
CLOCK INPUT 8	J CLOCK OUTPUT
BUSY OUTPUT 9	K +5VDC SYSTEM POWER INPUT
RUN / HOLD 10	L POWER GROUND INPUT

CAUTION: This meter employs high impedance CMOS inputs. Although internal protection has been provided for several hundred volt overloads, the meter will be destroyed if subjected to the high kilovolts of static discharge that can be produced in low humidity environments. Always handle the meter with ground protection.

Pin A - Reference Output: Internal precision voltage reference. Standard output is 1.0000V, adjustable ±5% by R10 potentiometer. Usable voltages from 0.1V to 2.49V for special high impedance scaling can be obtained by changing the value of internal dividing resistors R8 and R9. The primary reference voltage of the PM-45L is trimmed by potentiometer R20 to obtain the optimum compensated temperature coefficient. This temperature compensation network is omitted on the PM-45LU utility meter.

Pin B - Signal High Input: Pin B is the signal high input for all input signal ranges. When attenuation is not required, the resistor position R1A must be shorted by a jumper. Dividing resistors may be mounted internally in R1A and R2A positions to attenuate voltages up to 1200V max.. Matched dividing resistors for the 20V (1/10), 200V (1/100) and 1200V (1/1000) ranges are available from Texmate. Shunt resistors for current measurements up to 200mA may also be internally mounted in the R2A position. The current loop is then applied to Pin B and returned through Analog Common Pin C.

Pin C - Analog Common: Pin C is signal return common for differential inputs, ratiometric inputs, or external reference inputs. For single-ended inputs, Signal Low Input Pin 3 must be connected to Analog Common Pin C. To minimize any errors caused by ground loop currents, it is recommended that this connection be made as close as possible

to the input signal source ground.

Pins D, E, 4 and 6 - Decimal Select: Decimal points may be displayed as required by connecting the appropriate pin to Decimal Select Common Pin 5. Any number of decimal points can be turned ON at the same time. An open circuit will turn off the decimal points.

Pin F - No Connection: No connection has been made to this pin.

Pin H - Display Disable: If this pin is connected to the Power Ground Pin L, the display is disabled and the reading is blanked out. Only the polarity sign stays on to indicate that power is being applied to the meter. For normal operation, this pin is left unconnected.

Pin J - Clock Output: A quartz crystal controlled oscillator provides a stable clock signal output of 100KHz.

Pin K - +5VDC System Power Input: The meter requires a low ripple DC power supply of 4.5V to 5.5VDC at 225mA. The positive terminal of the power supply should be connected to Pin K.

Pin L - Power Ground Input: Negative terminal of the +5VDC power supply should be connected to Pin L. All digital signals, Display Test, and Run/Hold should be returned to this ground point. Pin L is internally connected to Analog Common Pin C.

Pin 1 - Reference Input: Reference voltage input for A to D converter. Normally supplied from Pin A. An external reference source referred to Pin C may be used instead. Pin 1 may be used as an input for ratiometric measurements. Minimum usable voltage is 0.1VDC, with a maximum voltage of 4.0V. For ratiometric operation; Displayed Reading = 10000 x (Signal Input Voltage ÷ Reference Input Voltage). The maximum signal input voltage is ±4V. Higher voltages must be scaled down through a voltage divider. Reference input voltage must remain stable during measurement period.

Pin 2 - Offset Voltage Output: 0 to +2.490V is available with the addition of a 3/4", 20KΩ to 100KΩ pot in the R15 position on the printed circuit board. The offset voltage is derived from the internal precision voltage reference and is available for applications requiring a zero offset such as 4~20mA receiver and temperature measurements.

Pin 3 - Signal Low Input: Pin 3 is the signal low input for all input signals. A special feature of the meter is the provision for dividing resistors to be mounted internally in the R1B and R2B positions. This enables signal low inputs up to 1200V max. to be attenuated, which is particularly useful when measuring small differential signals with a large common mode voltage. Matched dividing resistors for the 20V (1/10), 200V (1/100) and 1200V (1/1000) ranges are available from Texmate. Differential current measurements up to 200mA may also be made by internally mounting shunt resistors in the R2B position. The current loop is then applied to Pin B and returned through Analog Common Pin C. When attenuation is not required, the resistor position R1B must be shorted by a jumper.

Pin 5 - Decimal Select Common: Pin 5 serves as a common for the Decimal Select Pins D, E, 4 and 6. To turn on any required decimal point, connect the appropriate Decimal Select Pin to Decimal Select Common Pin 5.

Pin 7 - Display Test: If this pin is connected to the Power Ground Pin L, all segments of the display come on and 18888 is displayed. For normal operation, this pin is left unconnected.

Pin 8 - Clock Input: Normally Pin 8 is connected to the 100KHz clock output from Pin J, thereby providing the optimum rejection of 50/60Hz noise. However, an external clock source may be used instead (5V referenced to power ground with a recommended duty cycle of 50%). Minimum frequency is 10KHz, and maximum frequency is 1MHz (12.5 readings per sec.). For inputs below 100KHz or above 300KHz, changes to the integrator time constant and some component values are necessary.

Pin 9 - Busy Output: Pin 9 goes to logic "1" at the beginning of the signal integration and remains at "1" until the first clock pulse after the zero-crossing is detected at the completion of deintegration. In addition to its use as a Busy or End-of Conversion signal, the output on Pin 9 can be used in some control applications to indicate the digital reading of the meter as a function of time or clock pulses. Displayed Reading is equal to the total clock pulses during Busy less 10,000, or total elapsed time during Busy, less 100 milliseconds if the clock frequency is 100KHz.

Pin 10 - Run/Hold: If Pin 10 is left open (or connected to +5VDC System Power Input Pin K for logic control purposes), the meter will operate in a free-running mode. Under control of the internal 100KHz quartz crystal clock, readings will be updated every 400mS (2.5 per sec.). If Pin 10 is connected to Power Ground Input Pin L (logic low), the meter will continue the measurement cycle that it is doing, then latch up and continuously hold the reading obtained as long as Pin 10 is held low. If Pin 10 is released from Pin L (Pin 10 then goes logic high) for more than 300ns and returned to Pin L (logic low), the meter will complete one conversion, update, and then hold the new reading. For all practical purposes, a manually actuated normally closed pushbutton switch will provide sufficient timing for "press-to-update" operation.

Component Layout

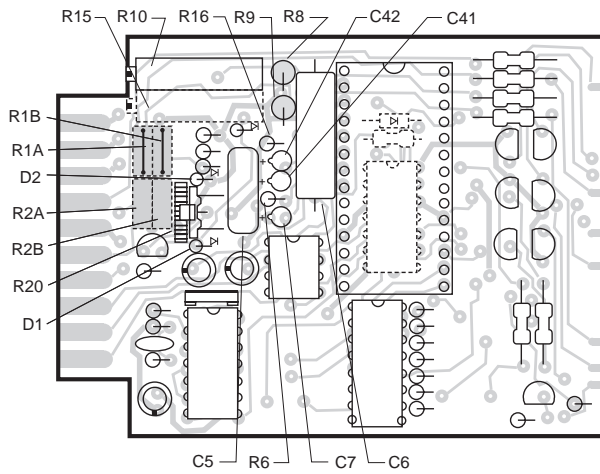

Signal Conditioning Components

SPAN SPAN Potentiometer (Pot)

The SPAN pot is on the right side of the display. Typical adjustment is 20% of the input signal range.

ZERO ZERO Potentiometer (Pot) optional

The ZERO pot is on the right side of the SPAN Pot. Typically it enables the displayed reading to be offset ± 500 counts.

BCD Output

The PM-45L and PM-45LU have a row of 18 Auxiliary Solder Pads that provide the means to access the multiplexed BCD signals generated by the Analog to Digital Converter.

PLEASE NOTE: An optional Tri-state Buffered Parallel BCD Output Board that mounts in the case and connects to the MUX BCD Auxiliary Solder Pads is available for the PM-45L and PM-45LU, either factory installed or as a user retrofit. Please see datasheets PM-45LBCD & PM-45LUBCD for more information.

Pad 1 - -5V Output: Auxiliary -5VDC power output for external use, 10mA max.

Pad 2 - Underrange Output: Pad 2, normally logic "0" (zero volts), goes to logic "1" (+5V) at the end of the deintegration period (end of Busy) when the reading is 9% of range or less than (1800) counts. Pad 2 is reset to logic "0" at the beginning of the next signal integrate (start Busy).

Pad 3 - Overrange Output: Pad 3, normally logic "0" (zero volts), goes to logic "1" (+5V) at the end of the deintegration period (end of Busy) when the reading is greater than 19999. Pad 3 is reset to logic "0" at the beginning of the next deintegrate (Reference integrate).

Pad 4 - Strobe Output: This is a negative going output pulse that aids in transferring the BCD data to external latches, UART's or micro-processors. There are 5 negative going Strobe pulses that occur once and only once for each measurement cycle starting 101 pulses after the end of the full measurement cycle. Digit 5 (MSD) Pad 15 goes high at the end of the measurement cycle and stays on for 201 counts. In the center of this digit pulse (to avoid race conditions between changing BCD and digit drives), the first Strobe pulse goes negative for a 1/2 clock pulse width. 200 pulses later the Strobe goes positive for the second time and at the same time Digit 4 (Pad 12) goes positive for the same 1/2 clock pulse width as the Strobe. This sequence then continues through Digit 1 (LSD) when the fifth and last Strobe pulse is sent. Except for Digit 5 (MSD), which will continue to scan (unless the previous signal was overrange), no additional Strobe pulses or digit pulses will be sent until a new conversion cycle has begun.

Pad 5 - Run/Hold: Same as Run/Hold Pin 10 (see PM-45L Pin Descriptions).

Pad 6 - System Ground: Same as Power Ground Input Pin L (see PM-45L Pin Descriptions).

Pad 7 - Polarity Sign Output: This output goes high (logic "1") for a positive signal input and low (logic "0") for a negative input. The output becomes valid at the beginning of the reference integrate and remains correct until it is revalidated for the next conversion.

Pad 8 - Clock Input: Same as Clock Input Pin 8 (see PM-45L Pin Descriptions).

Pads 9, 10, 11 and 12 - Digit Control Outputs: These outputs identify the BCD Data for D1, D2, D4 and D3 respectively. They are synchronized with the 5th, 4th, 3rd and 2nd Strobe outputs of Pad 4.

Pads 13, 14, 17 and 16 - BCD Data: True logic BCD Data output for 8, 4, 2, 1 or 23, 22, 21, 20 respectively, multiplexed synchronously with the Digit Control outputs.

Pad 15 - Digit Control Output D5: Unlike the other digit control outputs, D5 (most significant digit) goes high (logic "1") at the end of the measurement cycle for 201 clock pulses and then goes low (logic "0") for 800 clock pulses. This scan is continuous unless an overrange occurs, in which case the output for D5 is blanked from the end of the Strobe sequence until the beginning of the deintegration period when D5 will start the scan again. NOTE: The same output that the other digit controls have can be derived from Pad 15 (D5) by creating an AND Logic output with the inverse of Strobe output Pad 4.

Pad 18 - +5V Power Output: Auxiliary +5VDC power output for external use. It is connected internally to Pin K.

Calibration Procedure

VOLTAGE CALIBRATION 2V RANGE

After making the appropriate connections as shown in the instructions, apply power to the meter. Then, with a precision DC reference source, apply +1.9000VDC between the Signal High Input Pin B and the Signal Low Input Pin 3. Adjust R10 potentiometer (on left side as viewed from rear) until the display reads +1.9000V. NOTE: For other ranges, the voltage applied should be similarly proportionate to the particular full scale voltage.

TEMPERATURE COEFFICIENT COMPENSATION

The primary reference voltage of approximately 2.5V is generated by a precision IC-Zener Z1 (LM1/2/336). The PM-45L (not installed in the PM-45LU) has a temperature compensating network consisting of two diodes D1 and D2 and a potentiometer R20. R20 is factory calibrated so that the output of Z1, when measured at Test Point 1 (TP1) referred to Analog Common Pin C, is 2.490V which provides the optimum temperature coefficient for the average operating temperature range. For some applications, the user may wish to adjust the meter's temperature coefficient. Turn R20 clockwise to obtain a negative temperature coefficient (higher voltage and positive TC of primary ref.), and counter clockwise to obtain a positive temperature coefficient (lower voltage and negative TC of primary ref.). NOTE: Any adjustments of the primary reference voltage will necessitate a recalibration of the meter.

Typical Application Connections

The PM-45L/PM-45LU may be used in a wide variety of configurations. The following circuits illustrate some of the possibilities and demonstrate the exceptional versatility of Texmate products. Components called for in the applications which are not part of the standard meter may be supplied by the user or in some cases purchased from Texmate. The circuit diagrams explain the basic pinout connections required for each application. Unless otherwise specified, the diagrams will show the component values and solder junctions that would normally be installed on a standard 2V range meter. For those applications which have alternative ranges and/or input configurations, the required component values and any modifications are described in the text.

DIFFERENTIAL METER - 200mV RANGE, <2V RANGE

1) A 200mV range meter is shown measuring differential input signals with a high common mode rejection ratio of 86dB and a DC common mode voltage range of -2.8V to +2.8V. 2) A <2V range meter has the same CMV range. Higher CMV can be obtained by installing internal dividers (see next circuit).

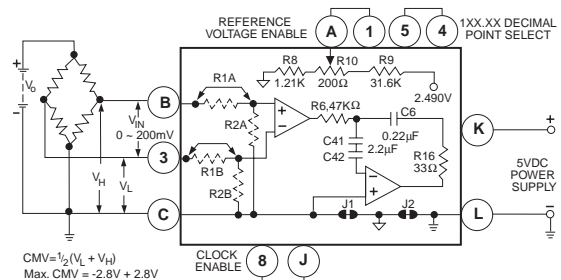

Optional PCB Edge Connector

PCB Edge Connector

A standard 20-pin edge connector (two rows of 10 pins on 0.156" centers) is used to connect the PM-Series of meters. Order part no. CN-L10.

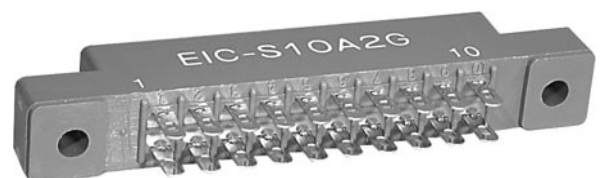

PM Case Dimensions and Panel Cutouts

The Slim Bezel Case is supplied as standard. If specified at time of ordering, any combination of Twin Mounting and Multiple Array Cases may be substituted at no additional cost. Extra cases may be ordered separately.

STANDARD SLIM BEZEL CASE

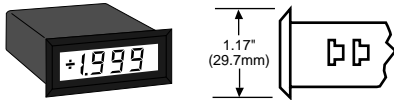

SLIM BEZEL CASE
Standard Black ABS case with matte finish bezel for single unit mounting.

Part No. **SL-CASERED** for LED's
SL-CASECLR for LCD's

OPTIONAL TWIN MOUNTING OR MULTIPLE ARRAY CASES

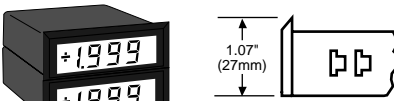

END MOUNT CASE

Same styling as Slim Bezel case but with bottom edge of bezel removed. Two End Mount cases can be twin mounted in a single cutout.

Part No. **EM-CASERED** for LED's
EM-CASECLR for LCD's



CENTER MOUNT CASE

Any number of Center Mount cases may be fitted between two End Mount cases for multiple arrays.

Part No. **CM-CASERED** for LED's
CM-CASECLR for LCD's

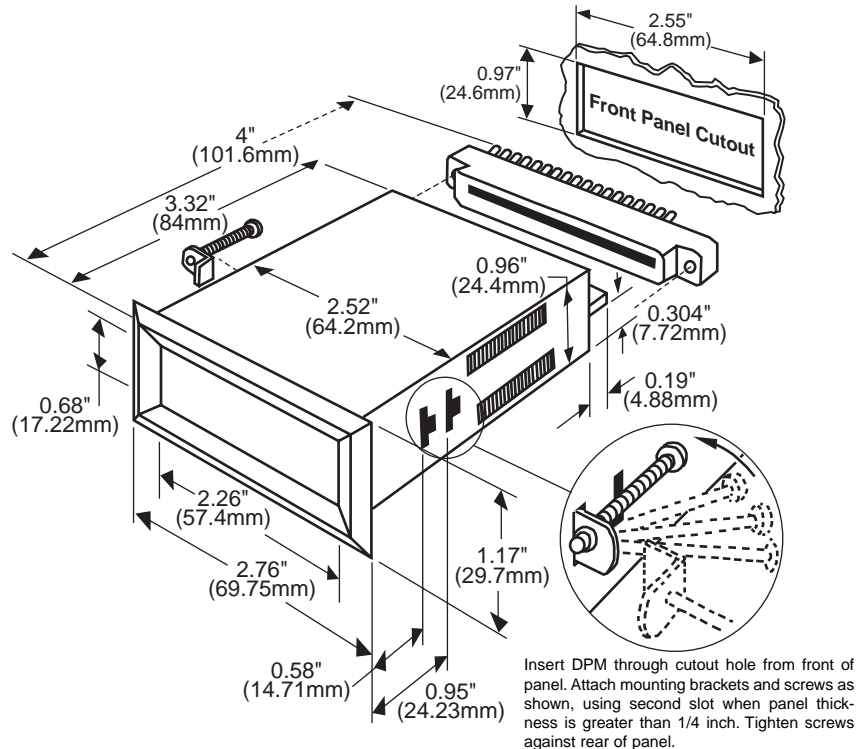

Insert DPM through cutout hole from front of panel. Attach mounting brackets and screws as shown, using second slot when panel thickness is greater than 1/4 inch. Tighten screws against rear of panel.

Ordering Information

Standard Options for this Model Number

Part Number .Description

► BASIC MODEL NUMBER

PM-45L4.5 digit Red LED, Precision Meter w/Differential Input
PM-45LU4.5 digit Red LED, Low Cost Meter w/Differential Input

Special Options and Accessories

Part Number .Description

► SPECIAL OPTIONS (Specify Inputs & Req. Reading)

VDA-200MVFI . . .200mVDC Range Change

VFA-0020V20VDC Range Change for 4.5 digit PM Series
VFA-0200V200VDC Range Change for 4.5 digit PM Series
VFA-1200V1200VDC Range Change for 4.5 digit PM Series
VS-4.5Non-Std Range and Scale - 4.5 Digit PM Meters

► ACCESSORIES

CN-L10Dual Row 10 Pin Connector, Solder Type
SL.CASEREDSlim Bezel Case, Red Faceplate w/Mtg Hardware
CL.CASEREDCenter Mount Case, Red Faceplate w/Mtg Hardware
EM.CASEREDEnd Mount Case, Red Faceplate w/Mtg Hardware

Prices subject to change without notice.

WARRANTY

Texmate warrants that its products are free from defects in material and workmanship under normal use and service for a period of one year from date of shipment. Texmate's obligations under this warranty are limited to replacement or repair, at its option, at its factory, of any of the products which shall, within the applicable period after shipment, be returned to Texmate's facility, transportation charges pre-paid, and which are, after examination, disclosed to the satisfaction of Texmate to be thus defective. The warranty shall not apply to any equipment which shall have been repaired or altered, except by Texmate, or which shall have been subjected to misuse, negligence, or accident. In no case shall Texmate's liability exceed the original purchase price. The aforementioned provisions do not extend the original warranty period of any product which has been either repaired or replaced by Texmate.

USER'S RESPONSIBILITY

We are pleased to offer suggestions on the use of our various products either by way of printed matter or through direct contact with our sales/application engineering staff. However, since we have no control over the use of our products once they are shipped, NO WARRANTY WHETHER OF MERCHANTABILITY, FITNESS FOR PURPOSE, OR OTHERWISE is made beyond the repair, replacement, or refund of purchase price at the sole discretion of Texmate. Users shall determine the suitability of the product for the intended application before using, and the users assume all risk and liability whatsoever in connection therewith, regardless of any of our suggestions or statements as to application or construction. In no event shall Texmate's liability, in law or otherwise, be in excess of the purchase price of the product.

Texmate cannot assume responsibility for any circuitry described. No circuit patent or software licenses are implied. Texmate reserves the right to change circuitry, operating software, specifications, and prices without notice at any time.

TEXMATE INC

995 Park Center Drive • Vista, CA 92081-8397

Tel: 1-760-598-9899 • USA 1-800-839-6283 • That's 1-800-TEXMATE

Fax: 1-760-598-9828 • Email: sales@texmate.com • Web: www.texmate.com

Texmate has facilities in Japan, New Zealand, Taiwan, and Thailand. We also have authorized distributors throughout the USA and in 28 other countries.

For product details visit www.texmate.com

Local Distributor Address

Copyright © 2003 Texmate Inc. All Rights Reserved.