

DIRECT PRESSURE SENSOR INPUT MODULE

DIRECT PRESSURE SENSOR

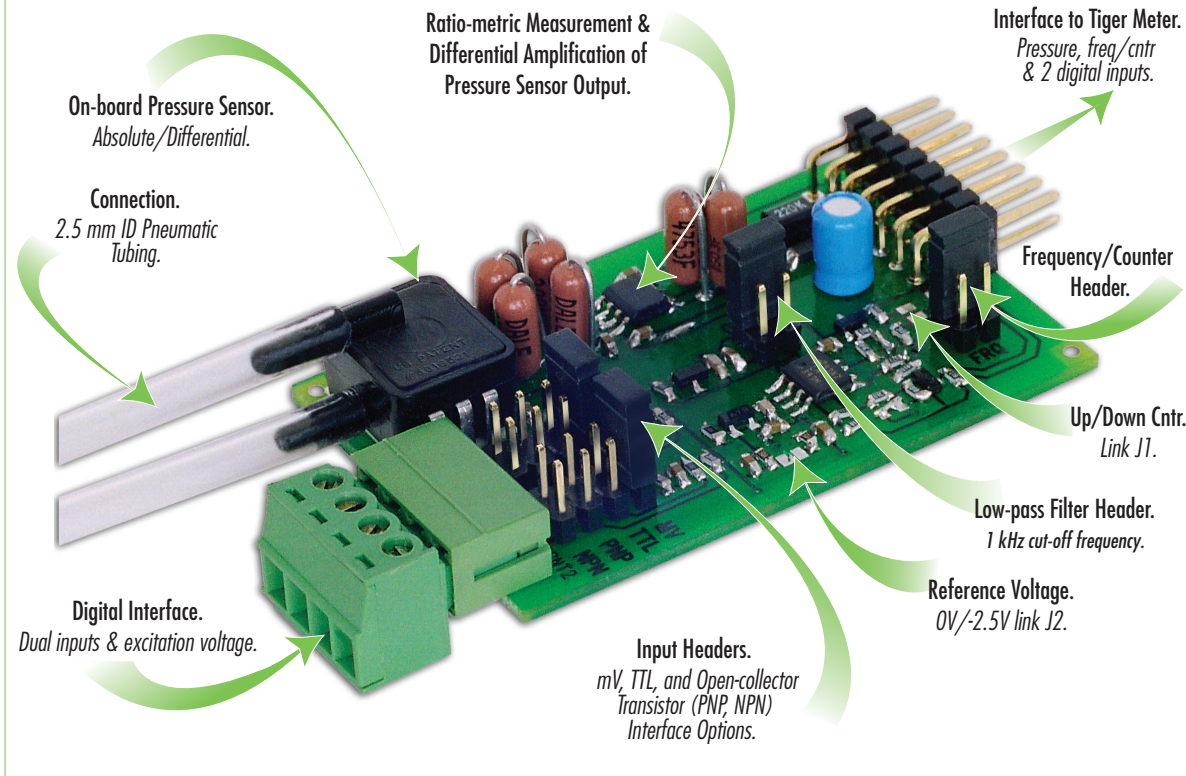

An on-board pressure sensor combined with dual digital inputs.

A cost effective solution for pressure applications requiring monitoring and process control of non-corrosive, non-ionic working fluids such as air, dry gases and similar. The pressure sensor is available in absolute and differential models and pressure ranges from 0 to 100 psi. Two independent digital inputs and a 24 V excitation voltage provide additional transducer and/or logic interfaces for measuring such variables as flow rate of the fluid being monitored.

Input Module Order Code Suffix IGYX

I G X

Sensor Range	CH1
1 psi absolute	A
1 psi differential	B
5 psi absolute	C
5 psi differential	D
15 psi absolute	E
15 psi differential	F
30 psi absolute	G
30 psi differential	H
100 psi absolute	J
100 psi differential	K

For Single Channel IGYX with two status inputs, the last digit of the order code is always X.

For example, IGD_X:

CH1 5 psi, differential pressure.



Hardware Module Specifications

Pressure Inputs Channel 1	Absolute or differential connections via 2.5 mm I.D. pneumatic tubing.
Pressure Ranges	0-1, 0-5, 0-15, 0-30, and 0-100 psi. Temperature compensated 0-50 °C, ± 0.4% F.S.
Max Pressure any Port	150 psi.
Repeatability	± 0.2% F.S. typical.
Linearity/Hysteresis	± 0.2% F.S. typical.
Digital Inputs	Dual independent digital inputs. Input 1(Channel 2) can be configured to measure frequency, or as an UP/DOWN counter and as a digital input (D1). Input 2 is treated as a digital input only (D2). In both cases, frequency response is dependent on meter update rate.
Input Headers	Configured for mV, TTL, OC (NPN/PNP) interface. Millivolt reference to 0 V (open jumper J2) TTL/PNP/NPN referenced to -2.5 V (close jumper J2)
Excitation Voltage	24 V DC (50 mA) available for external signal excitation.
Low-pass Filter Header	Set to OFF position for high speed update. Set to ON for 1 kHz cut off frequency low-pass filter. (Does not apply to Input 2.)
Frequency/Counter Header	Input 1 selected as either a frequency or counter input. Up counter: open jumper J1. Down counter: close jumper J1. (Does not apply to Input 2.)

INPUTS

☆ DIRECT PRESSURE

PRESSURE

FREQUENCY
RPM, Pulse, Counter

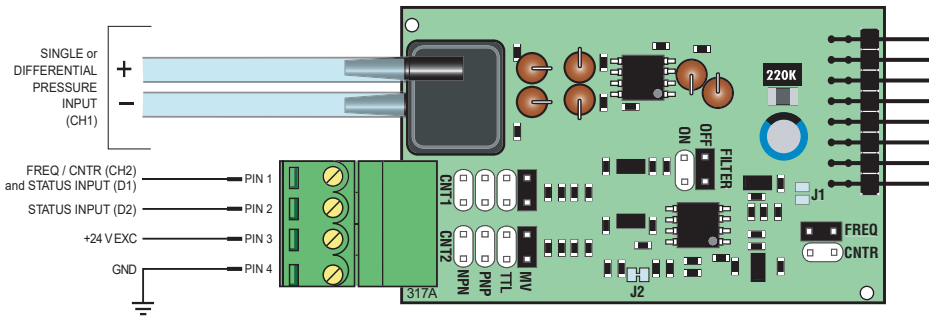

Figure 1 – IGYX Direct Pressure Sensor Input Module

Detailed Description

The Tiger 320 Series controller has four input channels capable of processing almost any input signal type. The direct pressure sensor input module IGYX uses only channels 1 and 2 and also the controller's digital inputs D1 and D2.

The input module processes the pressure input via a built-in pressure sensor capable of processing an absolute or differential pressure input. The pressure signal is then fed to CH1 for further processing. Gain setting resistors are factory installed to optimize the full scale output for each pressure range. Contact Texmate when ordering to discuss your pressure range requirements.

In addition to the pressure sensor, there is a digital interface with independent dual inputs and a 24 V excitation voltage. Each input uses an input header to interface to standard open collector (PNP or NPN), TTL, or millivolt digital signals. Frequency or counter inputs are fed through input 1 where they are conditioned and have the option of low-pass filtering, via a selection header, then fed to CH2 for further processing. Input 1 can also receive status inputs that are conditioned and fed to the controller's digital input D1, where it can be used for setpoint control or macro functions. Input 2 receives status inputs that are conditioned and fed to the controller's digital input D2, where it can also be used for setpoint control or macro functions.

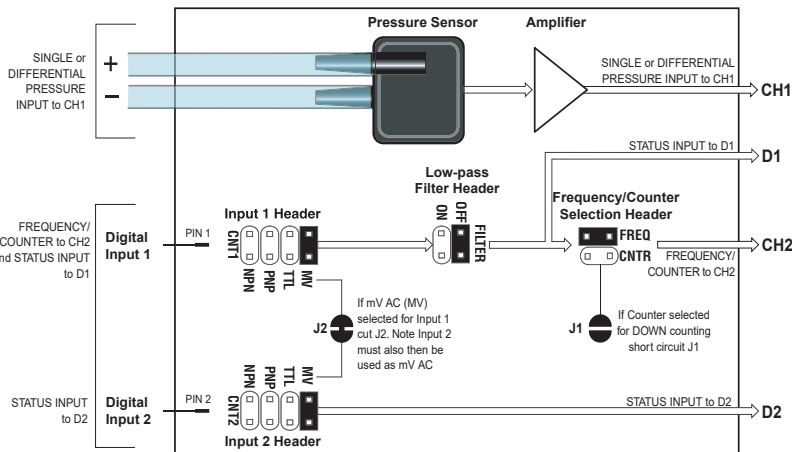

Figure 2 – IGYX Direct Pressure Sensor Input Module Signal Flow Diagram

Tiger 320 Series Meter Settings

Channel 1 (CH1) and channel 2 (CH2) configuration settings for the IGYX input module are selected in Codes 2 and 4 of the Tiger 320 Series meter's main programming mode. CH1 single or dual pressure input settings are configured in Code 2 and must be selected as a voltage input. CH2 frequency and counter settings are configured in Code 4.

CH1 → PRESSURE INPUT → CODE 2 → [X00] Select analog sample and output rate as required.
1st Digit: X

FIRST DIGIT	
ANALOG SAMPLE RATE	
0 Sample Rate: Typically 10 samples/second (60 Hz) Control Output Rate: 0.1 seconds See Example	Example: 10 Samples/Second 1 Channel = 10 samples/second 2 Channels = 5 samples/second 3 Channels = 3.33 samples/second 4 Channels = 2.5 samples/second
1 Sample Rate: Typically 10 samples/second (50 Hz). Control Output Rate: 0.1 seconds See Example	
2 Sample Rate: Typically 10 samples/second (60 Hz) Counter or 10 millisecons Control Output Rate See Example	
3 Sample Rate: Typically 10 samples/second (50 Hz) Counter or 10 millisecons Control Output Rate See Example	
Note: Output Rate refers to setpoint and macro outputs, and input rates from smart input modules.	
Note: All above sample rates are quoted for single channel operation. Where more than one channel is available, sample rates are divided by the number of active channels. See Example.	

See the Tiger 320 Series Programming Code Sheet for a complete list of main and setpoint mode programming code settings.

2nd Digit: 0 Selects **Voltage, Current.** (any other selection will not work)

3rd Digit: 0 Selects **No function.** (any other selection will not work)

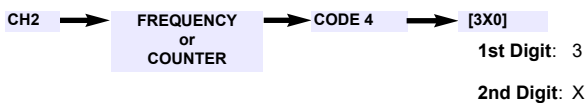

1st Digit: 3 Selects second digital input channel.

2nd Digit: X Select required **Frequency** or **Counter** setting.

DIGITAL INPUT	
0	Frequency - 99.999 Hz range from 0.001 Hz
1	Frequency - 999.99 Hz range from 0.01 Hz
2	Frequency - 99.999 kHz range from 1 Hz (1 s gate)
3	Frequency - 500 kHz range from 10 Hz (0.1 s gate)
4	Period - 9.9999 s (100 μs resolution)
5	Period - 999.99 ms (10 μs resolution)
6	Up/Down Counter with Prescaler
7	Set Prescaler

3rd Digit: 0 Set to 0.

Status inputs D1 and D2 are an activation source for any of the six available setpoints. The selected setpoint is individually configured in the setpoint control function settings menu of the setpoint programming mode. Enter the setpoint programming mode, adjust the activation value of the selected setpoint, and then enter the relevant setpoint control function menu (SPC_X) and select the required status input (D1 or D2).

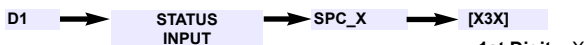

1st Digit: X Select the required relay energize function for the selected setpoint.

2nd Digit: 3 Selects digital input **D1** as the selected setpoint activation source.

3rd Digit: X Select the required setpoint function for the selected setpoint.

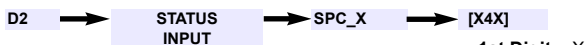

1st Digit: X Select the required relay energize function for the selected setpoint.

2nd Digit: 4 Selects digital input **D2** as the selected setpoint activation source.

3rd Digit: X Select the required setpoint function for the selected setpoint.

Interface Configuration Examples

The following example diagrams show the various header settings required for a range of digital inputs to the digital interface (inputs 1 and 2). Inputs to the pressure sensor are not shown, but can be either absolute or differential.

Example 1 – Frequency Input with 1 kHz Low-pass Filter

Figure 3 shows a transducer with an open collector NPN transistor output connected to digital input 1 (CH2/D1). In this case the transducer has its own power supply and the signal output is an open collector NPN transistor. By positioning input header CNT1 to the NPN position, a 10 kΩ pull-up resistor ties the transducer signal to +24 V. The negative supply of the transducer is common to the ground (GND) pin of the input module. When the transistor switches ON, the voltage of digital input 1 changes from +24V to -2.5 V (J2 closed).



Header Note:

- Input 1 Header CNT1 set to NPN.
- Low-pass Filter Header set to ON.
- FREQ/CNTR Header set to FREQ.

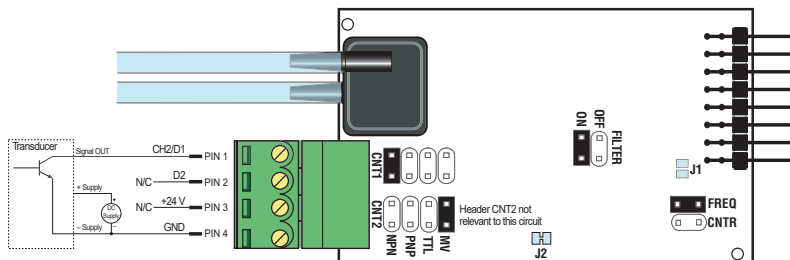

Figure 3 – Open Collector PNP Transistor Connected to Digital Input 1

Example 2 – Monitoring Voltage Level Shifts

Figure 4 shows a transducer with an open collector PNP transistor output type connected to digital input 2 (D2) to monitor voltage level shifts. In this example the transducer uses the +24 V supply of the Tiger meter. By positioning input header CNT2 to the PNP position, a 10 kΩ pull-down resistor ties the transducer signal to -2.5 V (J2 closed). When the transducer switches ON, the signal output changes from -2.5 V to +24 V DC. The Tiger 320 Series controller software reads digital input D2.



Header Note:

In this case the position of headers Input 1 Header CNT1, Low-pass Filter Header, and FREQ/CNTR Header do not matter as the digital status input is only fed via input 2 to digital input D2.

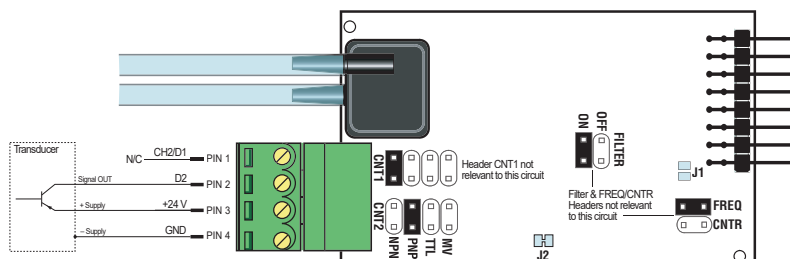

Figure 4 – Open Collector PNP Transistor Connected to Digital Input 2

Example 3 – TTL Output Configured as a HS Down Counter

Figure 5 shows a transducer having its own external power supply of +5 V DC connected to digital input 1 and configured as a high speed down counter on CH2. Input header CNT1 is positioned for TTL and this forces the 0 to 5 V transducer signal to be pulled down to -2.5 V (J2 closed). This ensures the input signal varies about 0 V and all counts are detected.

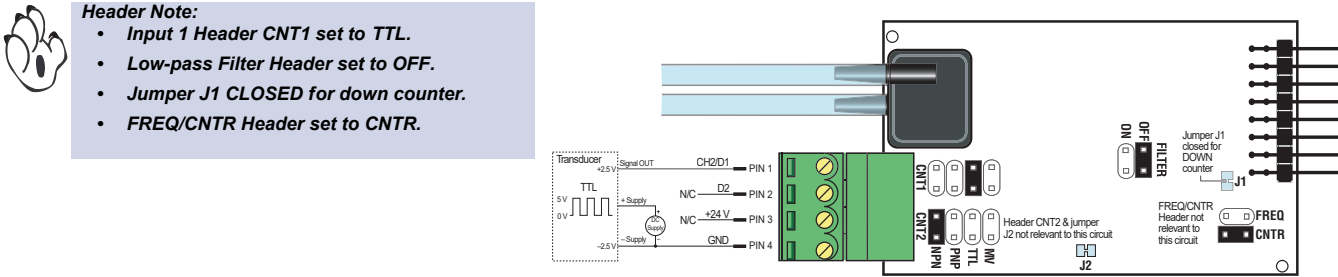

Figure 5 – TTL Signal Connected to Digital Input 1

Example 4 – Transducer Input Configured as Up Counter

Figure 6 shows a transducer that produces a slow 300 mV peak-to-peak output. The magnitude of the signal is less than 2.5 V peak-to-peak. This means jumper J2 must be cut so that the mean signal passes through zero. The signal is connected to input 1 as an up counter with low-pass filtering.

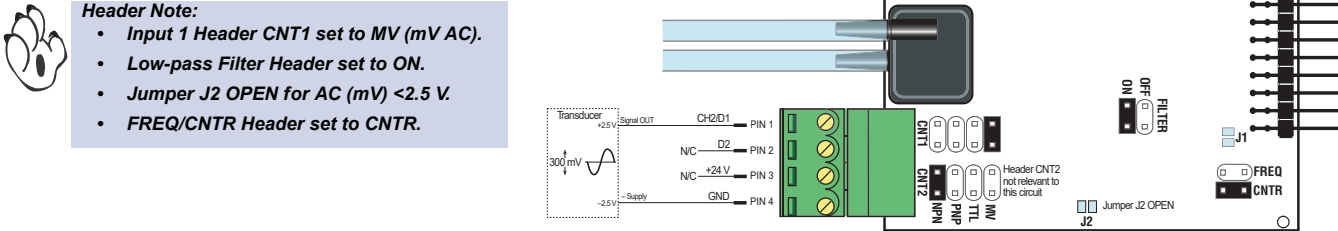

Figure 6 – mV AC Signal Connected to Digital Input 1

Example 5 – Switch Closure

Figure 7 shows a switch connected to both digital inputs. Digital input 1 acts as an up counter with low-pass filtering to record the number of switch closures. Digital input 2 acts as a status input on D2. Input 1 header (CNT1) and input 2 header (CNT2) are set to NPN for 10 k pull-up resistors to +24 V. Closing the switch sets both inputs to -2.5 V.

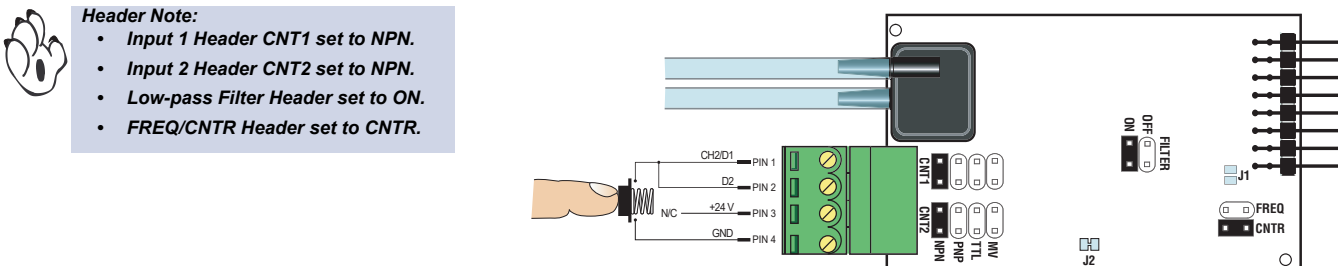

Figure 7 – Switch Closure for Digital Input 1 and 2

WARRANTY

Texmate warrants that its products are free from defects in material and workmanship under normal use and service for a period of one year from date of shipment. Texmate's obligations under this warranty are limited to replacement or repair, at its option, at its factory, of any of the products which shall, within the applicable period after shipment, be returned to Texmate's facility, transportation charges pre-paid, and which are, after examination, disclosed to the satisfaction of Texmate to be thus defective. The warranty shall not apply to any equipment which shall have been repaired or altered, except by Texmate, or which shall have been subjected to misuse, negligence, or accident. In no case shall Texmate's liability exceed the original purchase price. The aforementioned provisions do not extend the original warranty period of any product which has been either repaired or replaced by Texmate.

USER'S RESPONSIBILITY

We are pleased to offer suggestions on the use of our various products either by way of printed matter or through direct contact with our sales/application engineering staff. However, since we have no control over the use of our products once they are shipped, NO WARRANTY WHETHER OF MERCHANTABILITY, FITNESS FOR PURPOSE, OR OTHERWISE is made beyond the repair, replacement, or refund of purchase price at the sole discretion of Texmate. Users shall determine the suitability of the product for the intended application before using, and the users assume all risk and liability whatsoever in connection therewith, regardless of any of our suggestions or statements as to application or construction. In no event shall Texmate's liability, in law or otherwise, be in excess of the purchase price of the product.

Texmate cannot assume responsibility for any circuitry described. No circuit patent or software licenses are implied. Texmate reserves the right to change circuitry, operating software, specifications, and prices without notice at any time.

TEXMATE INC

1934 Kellogg Ave. • Carlsbad, CA 92008

Tel: 1-760-598-9899 • USA 1-800-839-6283 • That's 1-800-TEXMATE

Email: orders@texmate.com • Web: www.texmate.com