

3-RTD, 2-PROCESS, COUNTER INPUTS

3-RTD, 2-PROCESS, COUNTER INPUTS

INPUTS

PROCESS
4 / 20 mA
1 / 5 V

FREQUENCY
RPM, Pulse, Counter

TEMPERATURE

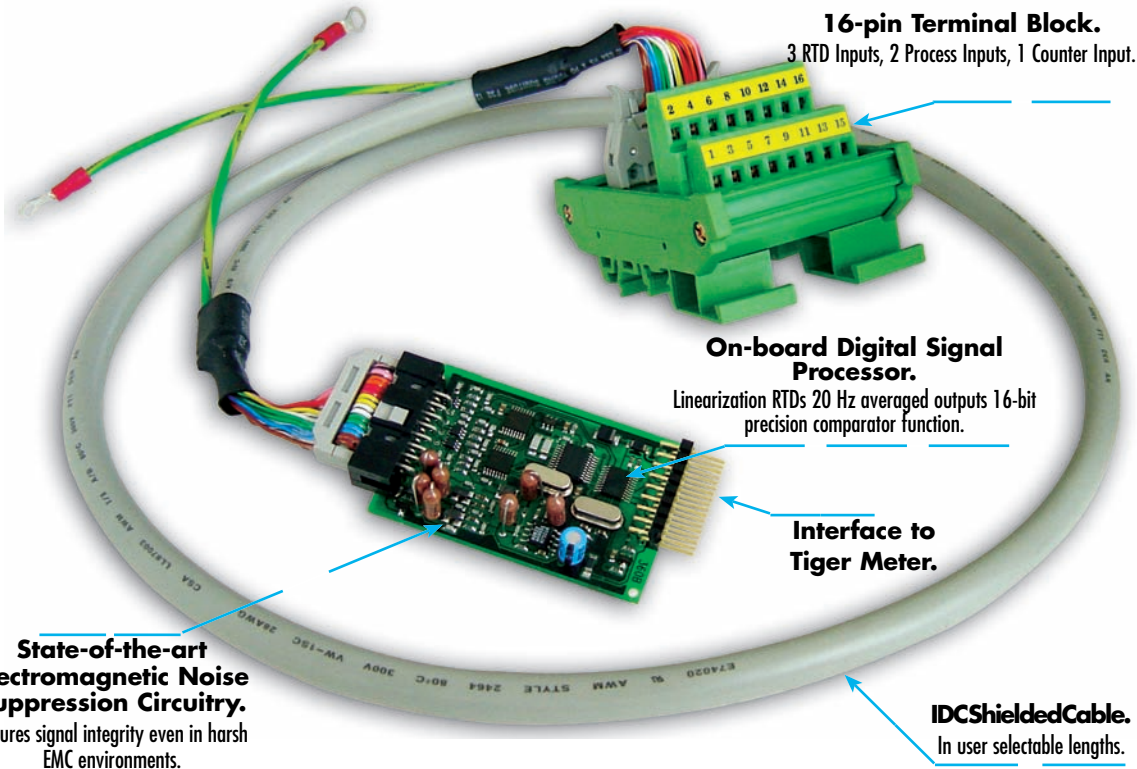

16-pin Terminal Block.
3 RTD Inputs, 2 Process Inputs, 1 Counter Input.

On-board Digital Signal Processor.
Linearization RTDs 20 Hz averaged outputs 16-bit precision comparator function.

Interface to Tiger Meter.

State-of-the-art Electromagnetic Noise Suppression Circuitry.
Ensures signal integrity even in harsh EMC environments.

IDC Shielded Cable.
In user selectable lengths.

Multiple inputs processed with powerful signal conditioning.

IST1 and IST2 are smart input modules that can monitor a combination of mixed temperature, process, and counter inputs. Both modules can accept three triple 3-wire RTD sensors, two 0-10 V / 4-20 mA process inputs, and a frequency input. Applied in multiple-point temperature measurement and automation / control applications, these modules can be user programmed to process any four of the six inputs, or programmed with a macro to process all six inputs.

Input Module
Order Code Suffix

IST1 (50 Hz Rejection)

IST2 (60 Hz Rejection)

Hardware Module Specifications

RTD	
Triple-input RTD	3-wire RTD configuration. Choice of Pt385 or Pt392.
Excitation Current	160 μ A DC constant current source, ratiometric referenced to ATD.
Resolution & Range	0.1 $^{\circ}$ C, -200 $^{\circ}$ C to +850 $^{\circ}$ C.
Process Inputs	
Dual Process Inputs	Bipolar, \pm 88 mV full scale.
Mode	Voltage or current range set by attenuation resistors.
Counter - CH1 Only	
Single Counter	Configured in Tiger 320 controller.
Analog-to-digital	
	Dual channel sigma delta ATD convertor.
	16-bit resolution.
	Shield drive +2.5 V.

Software Module Specifications

Line Frequency Rejection	50/60 Hz software selectable.
RTD Type	Pt385 / Pt392 software selectable.
RTD Linearization	On-board linearization tables for RTD.
2-point Calibration	Simple 2-point calibration of RTD & process inputs using Tiger 320 Series software.
Sampling Speed	800 / 960 Hz each channel, 20 Hz averaged outputs.



Fits Tiger 320 Series

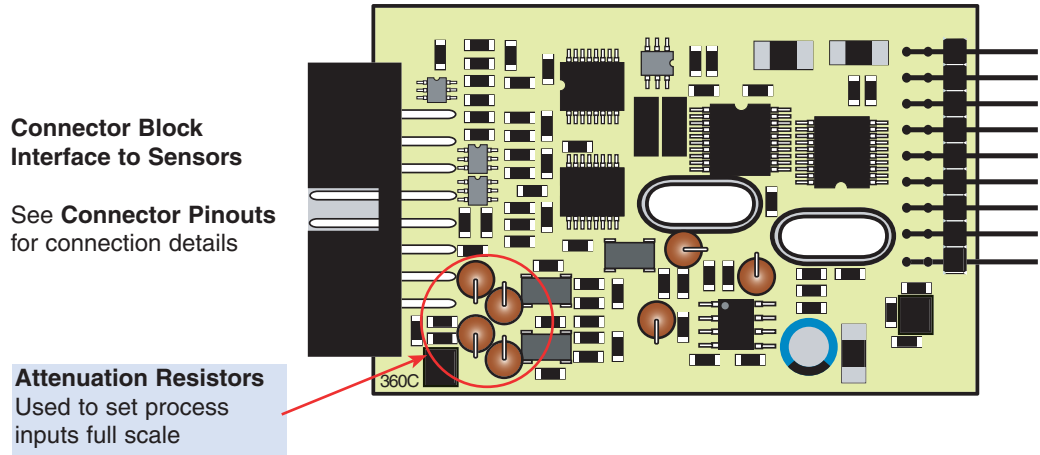

Figure 1 – IST1/IST2 Triple RTD, Dual Process, Counter Smart Input Module

Connector Pinouts

Connecting the sensors directly to the input module is an option, but it is far easier to connect sensors via the supplied 16-pin terminal block.

The external pinouts between the input module and the terminal block are shown in Figure 2.

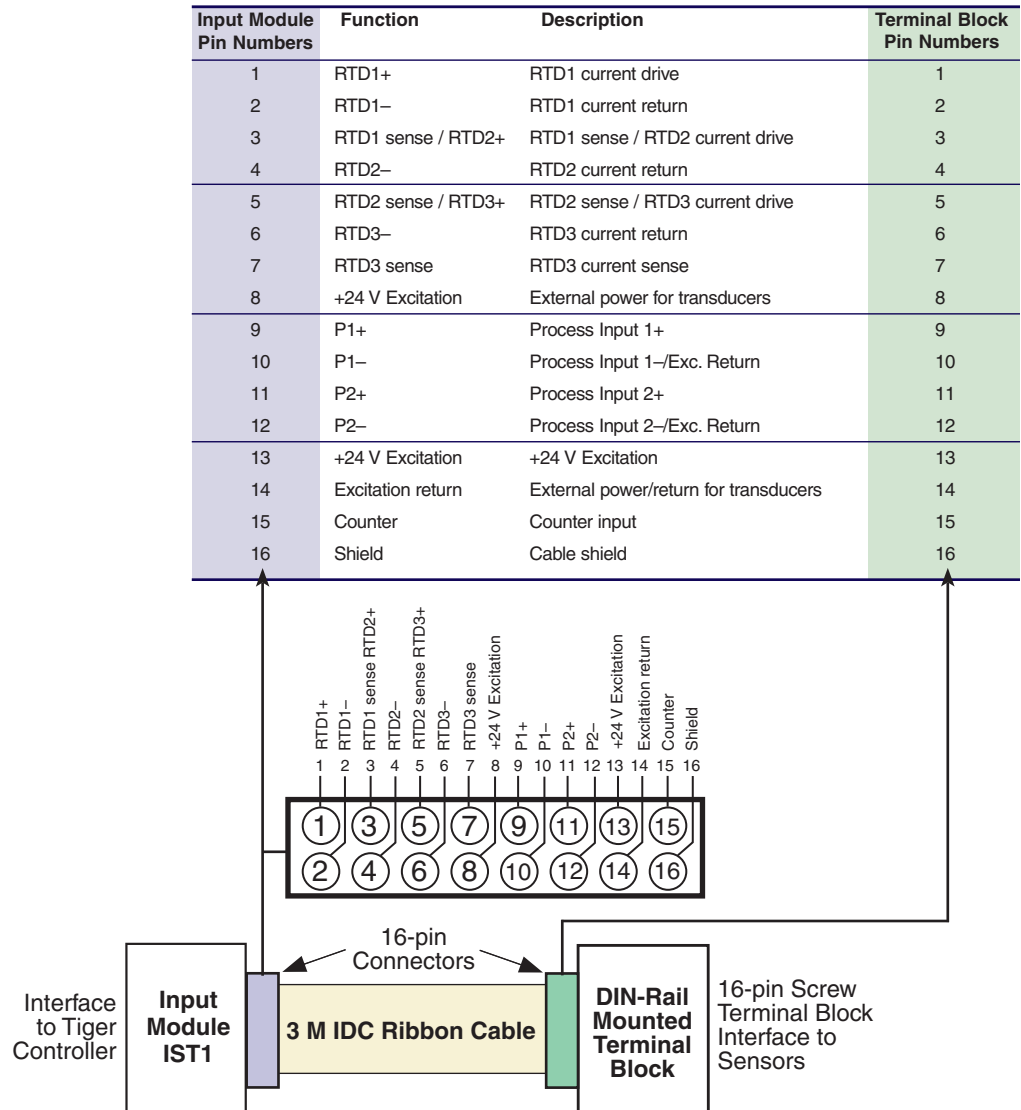

Figure 2 – IST1/IST2 to 16-pin DIN-Rail Mounted Terminal Block Connections

Example

Triple 3-wire RTDs connected to the terminal block in series.

In Figure 3, a magnetostrictive displacement sensor having a 0-10 V output and a resistive type displacement sensor derive their power from the input module's +24 V excitation and act as two process inputs. The counter input is a square wave generator and is normally a flow sensor or optical pickup type also receiving +24 V.

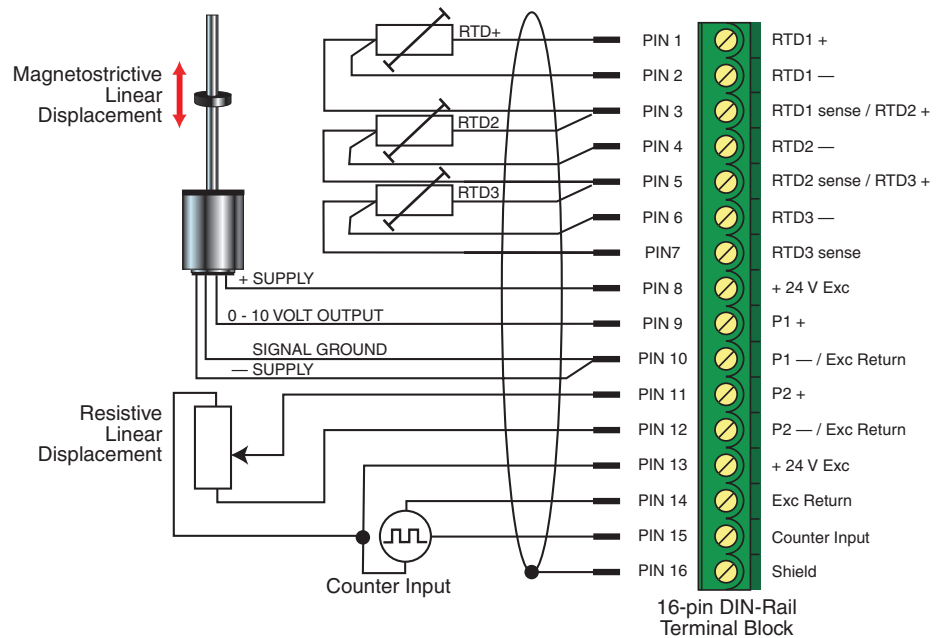

Figure 3 – Triple 3-wire RTDs connected to the terminal block in series

Overview

There are two methods of configuring the IST1/IST2 smart input module:

- By the user through the front panel using the code menus, or
- By preconfiguring the controller with a macro.

Front Panel Programming

The controller has four input channels available for processing sensor input signals when programming through the front panel. All six sensors can be connected to the input module at the same time, but only four can be selected and processed at any one time.

Macro Programming

With a macro installed, the controller can process all six sensor input signals at the same time. A macro can be either pre-compiled and installed by Texmate before the module leaves the factory, or compiled and installed by the customer. See Page 10 for a brief overview of the Tiger Macro Development System (TDS).

A full set of tutorial documents for macro programming are available online at www.texmate.com. Alternatively, printed copies can be sent on request.

Technical Description

Input module IST1/IST2 is designed for 3-wire RTDs that are either 100 Ω type Pt385 or Pt392. A constant current source ratiometric referenced to a precision 16-bit ATD drives all three RTDs wired in series at the

Therefore, if only a single or dual RTD combination is required, the unused RTD inputs must be short circuited to ensure the constant current loop is maintained.

The dual process inputs can be adapted to voltage or current inputs by modifying the values of thru hole attenuation resistors. This is manually done in the factory during assembly. Typically, either 0 to 10 V or 0 to 20/40 mA are required as process inputs. The dual process channels require the signals to be attenuated to ± 88 mV full scale by the resistors.

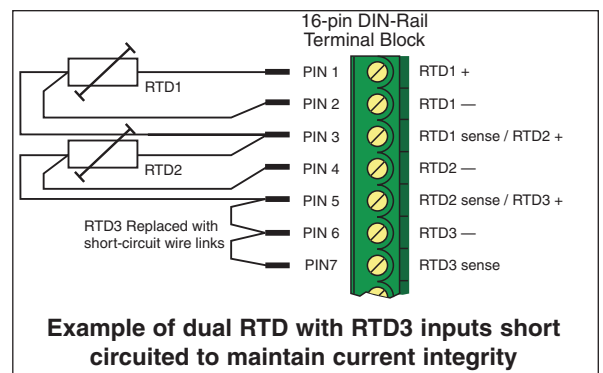

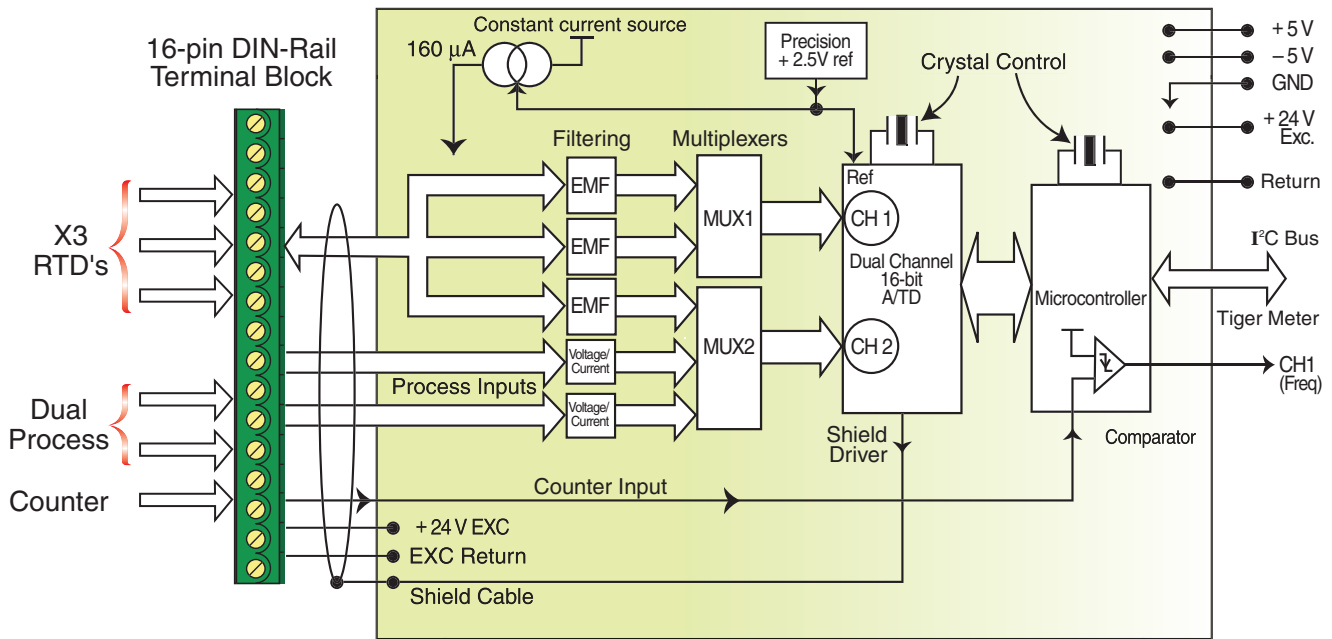
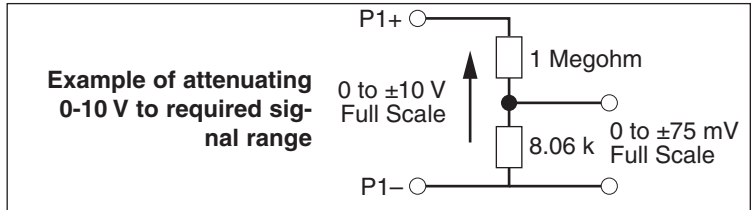
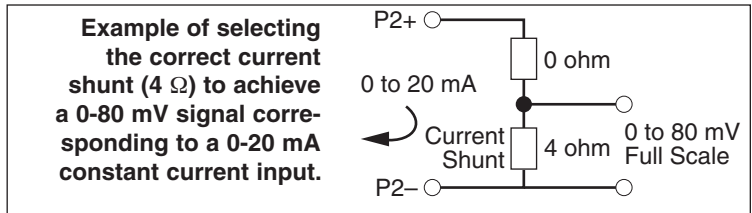

Figure 4 – Input Module IST1/IST2 Functional Schematic Diagram

The input module accepts a counter or pulse input such as from a paddlewheel flow sensor or equivalent. If this option is used, CH1 automatically defaults as the counter input.



External +24 V excitation and return is available to power external transducers if required.



Contact Texmate for your required process input type.

Smart Setup Registers

The Tiger controller uses three smart setup registers to configure all smart input modules. Line frequency rejection (50 / 60 Hz) and RTD type are configured in **smart register 1 (SMT1)**. See Figure 5.

Smart register 1 allows you to select the following settings:

- Line frequency rejection of 50 or 60 Hz for all four sensor inputs.
- RTD type: Pt385 or Pt392 for all RTD types.

A standard sampling rate of 800 / 960 Hz (50 / 60 Hz) is applied to all inputs.

The module produces five output registers (3 RTD and 2 process), each being the 20 Hz averaged result of the input sensors. One of these registers can be transferred to CH1 via Code 2, the same or another register transferred to CH2 via Code 4, the same or another register transferred to CH3 via Code 5, and the same or another register transferred to CH4 via Code 6. In addition, the module has a counter input that is hard-wired to CH1. If the counter is required, then only channels 2, 3, and 4 are available for RTD and process inputs.

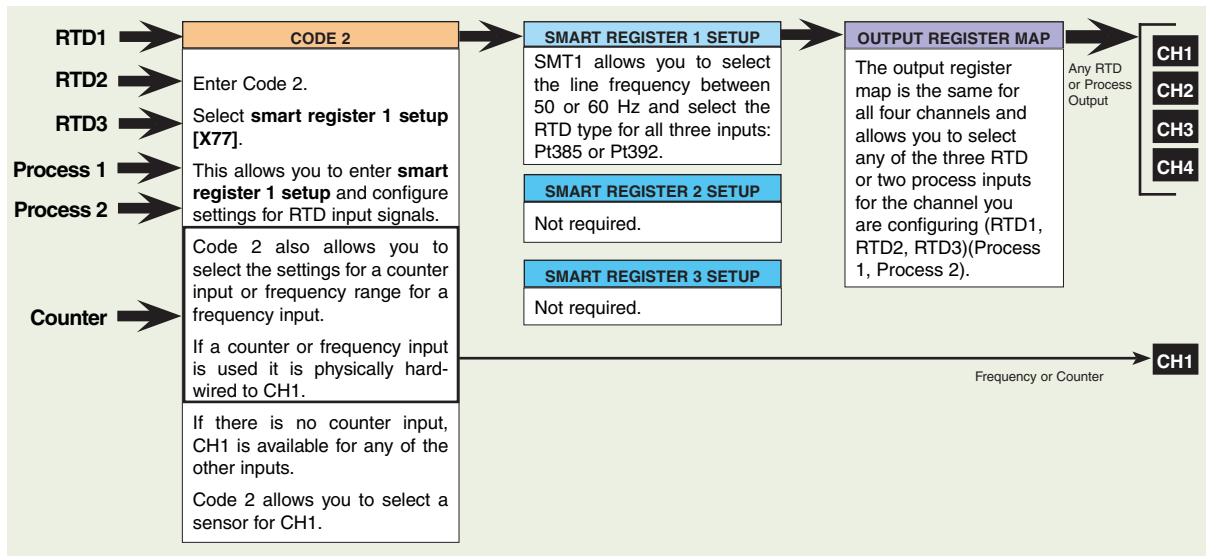

Figure 5 – IST1/IST2 Smart Setup Registers Operational Flow Diagram

Programming Procedures

The input module requires the following individual inputs to be programmed through the configuration menus in the controller:

1 Select Line Frequency Rejection & RTD Type

Cod_2 50761

This menu allows you to select the input signal line frequency rejection for all input signals (50 or 60 Hz) and the RTD type for all RTD inputs (Pt385 or Pt392) using Smart Register 1 (SMT1).

2 Setup Counter or Frequency Input

Cod_2 CH1

If a counter or frequency signal is used, this menu allows you to configure the frequency range or counter settings.

3 Select a Channel for the RTD or Process Input

Cod_2 CH1
 Cod_4 CH2
 Cod_5 CH3
 Cod_6 CH4

In the code for the required channel, select the relevant RTD or process input from the output register map.

Note: If a counter or frequency signal is not used, CH1 is available for RTD or process inputs.

Select RTD Type

Enter Code 2 and select the RTD type and input signal line frequency rejection setting for all inputs

- Press the **P** and **↑** buttons at the same time to enter the main programming mode.
- Press the **P** button three times to enter Code 2. Set Code 2 to [X77].
The 1st digit setting is not relevant to this procedure and can remain at zero (0).

Cod_2 [X77]

This setting enters the **smart register 1** code setup menu.

FIRST DIGIT
TIGER PROCESSING RATE
0 10 Hz
1 10 Hz
2 100 Hz
3 100 Hz

SECOND DIGIT
MEASUREMENT TASK
0 Voltage, Current
1 TC (3rd digit selects type of TC)
2 RTD 3-wire (3rd digit selects type of RTD)
3 RTD 2- or 4-wire (3rd digit selects type of RTD)
4 Frequency
5 Period
6 Counter
7 Smart Input Module

THIRD DIGIT
OUTPUT REGISTER MAP
0 Averaged RTD1
1 Averaged RTD2
2 Averaged RTD3
3 Averaged Process 1
4 Averaged Process 1
5 -
6 -
7 Smart input module register 1 code setup



Note: The output registers in the 3rd digit are specific to the IST1/IST2 input module. These registers vary for each different smart input module.



Note: The 20 Hz averaged signal is output for all five inputs.

- Press the **P** button.

SP7E 1 000

This menu provides settings unique to **smart register 1** of input module IST1/IST2.

FIRST DIGIT
FREQUENCY SELECT
0 60 Hz rejection
1 -
2 50 Hz rejection
3 -

SECOND DIGIT
NOT USED
0 -
1 -
2 -
3 -
4 -
5 -
6 -
7 -

THIRD DIGIT
RTD TYPE
0 Pt385 100 Ω
1 Pt392 100 Ω
2 -
3 -
4 -
5 -
6 -
7 -

- Using the **↑**/**↓** buttons, select either **50 or 60 Hz line frequency rejection** (2 for areas with 50 Hz power supplies and 0 for areas with 60 Hz power supplies) in the 1st digit and the **RTD type** in the 3rd digit.
2nd digit settings are not relevant and should be left at zero (0).

Setup Counter or Frequency Input

On leaving Code 2, setup counter or frequency settings

- Press the **P** button. The display returns to [Cod_2] [X77].

- Using the **↑**/**↓** buttons, set the 1st digit to the relevant processing rate, the 2nd digit to either Frequency or Counter, and the 3rd digit to the relevant frequency range or counter setting..
Note, leaving the 3rd digit as 7 means the display constantly cycles between [Cod_2] and [SMt1].

Cod_2 [X4X] For Frequency

Cod_2 [X6X] For Counter

CH1 Cod_2
Frequency
OR
Counter

FIRST DIGIT
TIGER PROCESSING RATE
0 10 Hz
1 10 Hz
2 100 Hz
3 100 Hz

SECOND DIGIT
MEASUREMENT TASK
0 Voltage, Current
1 TC (3rd digit selects type of TC)
2 RTD/Resistance 3-wire (3rd digit selects type of RTD)
3 RTD/Resistance 2- or 4-wire (3rd digit selects type of RTD)
4 Frequency
5 Period
6 Counter
7 Smart Input Module

THIRD DIGIT
FREQUENCY RANGE SELECTION
0 99.999 Hz range from 0.010 Hz
1 99.999 Hz range from 2.000 Hz
2 999.99 Hz range from 0.01 Hz
3 999.99 Hz range from 2.00 Hz
4 9999.9 Hz range from 0.1 Hz
5 9999.9 Hz range from 2.0 Hz
6 99 kHz range from 1 Hz (1 s gate)
7 655.35 kHz range from 10 Hz (0.1 s gate)

COUNTER
0 Counter input with 16-bit Pre-scaler
1 Setting of 16-bit Pre-scaler
2 Debounced Counter with Pre-scaler
3 Up/Down Counter with Pre-scaler
4 -
5 -
6 -
7 -

- Press the **P** and **↑** buttons at the same time to return to the operational display.

Select a Channel

Select a channel for the RTD or process input from the output register map of the required channel

Channel 1

If a counter or frequency input has **not** been applied to CH1, then this channel is still available for an RTD or process input signal. To select an RTD or process signal for CH1:

- 8 Press the **P** and **↑** buttons at the same time again to re-enter the main programming mode, then press the **P** button three times to enter Code 2.
- 9 Set Code 2 to [X7X]. Select the required processing rate for all input sensors in the 1st digit and the required RTD or process signal in the 3rd digit.



Note: The output register map is different for each smart input module type.

CH1 Cod_2 [X7X]

FIRST DIGIT	SECOND DIGIT	THIRD DIGIT
TIGER PROCESSING RATE	MEASUREMENT TASK	OUTPUT REGISTER MAP
0 10 Hz 1 10 Hz 2 100 Hz 3 100Hz	0 Voltage, Current 1 TC (3rd digit selects type of TC) 2 RTD 3-wire (3rd digit selects type of RTD) 3 RTD 2- or 4-wire (3rd digit selects type of RTD) 4 Frequency 5 Period 6 Counter 7 Smart Input Module	0 Averaged RTD1 1 Averaged RTD2 2 Averaged RTD3 3 Averaged Process 1 4 Averaged Process 2 5 - 6 - 7 Smart input module register 1 code setup

Channel 2

- 10 Enter Code 4 and set to [0X0]. Select the required register map settings for **CH2** in the 2nd digit. See *Note in 2nd digit below.

CH2 Cod_4 [0X0]

FIRST DIGIT	SECOND DIGIT										
MEASUREMENT TASK	FOR VOLTAGE & CURRENT										
0 Voltage, Current 1 TC (type as per 2nd digit) 2 RTD (type as per 2nd digit) 3 Second Digital Input Channel (type as per 2nd digit)	0 Channel 2 Disabled 1 Direct (no post processing) 2 Square Root of Channel 2 3 Inverse of Channel 2 4 Output Register 1 (smart module)* 5 Output Register 2 (smart module)* 6 Output Register 3 (smart module)* 7 Output Register 4 (smart module)*										
	<p>*Note: The logic for CH2 is not the same as CH1, CH3, or CH4. The 1st and 3rd digits must both be set to 0. Selecting 040 to 070 in the 2nd digit of Code 4 directly selects one of the following settings in the output register map</p> <table border="1"> <thead> <tr> <th>(3rd-digit): 2nd Digit</th> <th>Output Register Map</th> </tr> </thead> <tbody> <tr> <td>4 selects</td> <td>0 Averaged RTD1</td> </tr> <tr> <td>5 selects</td> <td>1 Averaged RTD2</td> </tr> <tr> <td>6 selects</td> <td>2 Averaged RTD3</td> </tr> <tr> <td>7 selects</td> <td>3 Averaged Process 1</td> </tr> </tbody> </table>	(3rd-digit): 2nd Digit	Output Register Map	4 selects	0 Averaged RTD1	5 selects	1 Averaged RTD2	6 selects	2 Averaged RTD3	7 selects	3 Averaged Process 1
(3rd-digit): 2nd Digit	Output Register Map										
4 selects	0 Averaged RTD1										
5 selects	1 Averaged RTD2										
6 selects	2 Averaged RTD3										
7 selects	3 Averaged Process 1										



Note: Unlike CH1, you cannot select Averaged Process 2 in CH2.

Channel 3

- 11 Enter Code 5 and select the required register map settings for **CH3** in the 3rd digit.

CH3 Cod_5 [X7X]

FIRST DIGIT	THIRD DIGIT
CH3 POST PROCESSING	OUTPUT REGISTER MAP
0 Direct Display of Input (no processing) 1 Square Root of Channel 3 2 Inverse of Channel 3 3 Meters with 4 kB memory NO Linearization Meters with 32 kB memory 32-point Linearization of CH3 using Table 3 <i>Note:</i> All linearization tables are set up in the Calibration Mode [24X].	0 Averaged RTD1 1 Averaged RTD2 2 Averaged RTD3 3 Averaged Process 1 4 Averaged Process 2 5 - 6 - 7 Smart input module register 1 code setup

Channel 4

- 12 Enter Code 6 and select the required register map settings for **CH4** in the 3rd digit.

CH4 Cod_6 [X7X]

FIRST DIGIT
CH4 POST PROCESSING
0 Direct Display of Input (no processing) 1 Square Root of Channel 4 2 Inverse of Channel 4 3 Meters with 4 kB memory NO Linearization Meters with 32 kB memory 32-point Linearization of CH4 using Table 4 <i>Note:</i> All linearization tables are set up in the Calibration Mode [24X].



Note: The output register map is different for each smart input module type.

- 13 Press the **P** button to save the settings.

- 14 Press the **P** and **↑** buttons at the same time to return to the operational display.

Example 1:

User Programmable Application

Example 1 describes the setup procedure for measuring the volume, temperature, and flow rate of a milk vat using front panel programming.

The volume of the milk vat is monitored using a linear displacement transducer and float arrangement. A pump transfers the milk past a flow rate sensor. The milk vat temperature and discharge temperature are monitored using type Pt392 RTD sensors.

The input module is wired via the 16-pin DIN-rail mounted terminal block. See Figure 7 for connection details between the terminal block and the input sensors. The inputs are designated to the following channels:

- CH1: Flow rate sensor – Frequency input.
- CH2: Milk vat temperature – RTD2 input.
- CH3: Discharge temperature – RTD3 input.
- CH4: Milk volume – Process 1 input.



Note: RTD1 is not used. Process input 2 is not used. The frequency input automatically defaults to CH1.

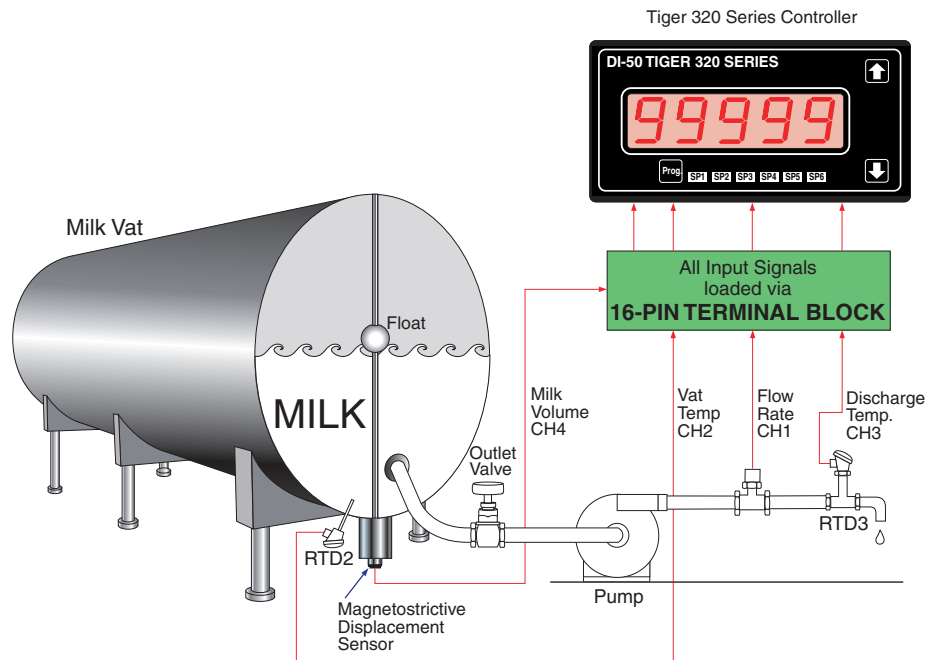
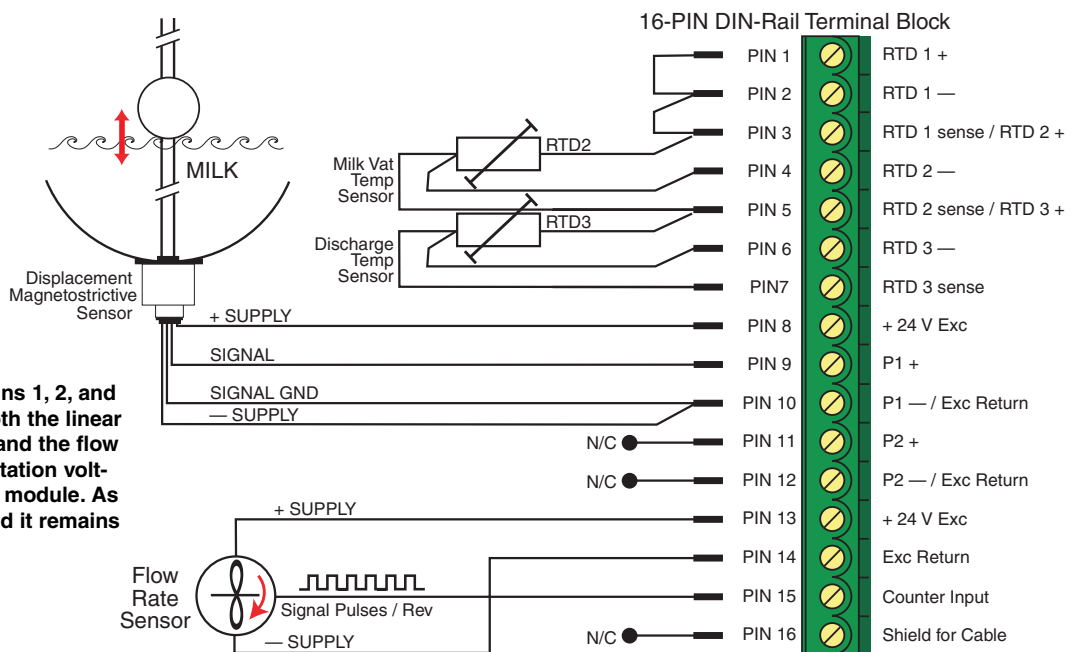

Figure 6 – Example 1: Using IST1/IST2 in a User Programmable Application



Note: RTD1 is not used, pins 1, 2, and 3 are shorted together. Both the linear displacement transducer and the flow rate sensor take their excitation voltage (+24 V) from the input module. As process input 2 is not used it remains unconnected.

Figure 7 – Example 1: Application Wiring of Sensor Inputs to 16-pin Terminal Block

Example 1 Setup Procedure

- 1** Select 50 Hz input line frequency rejection with Pt392 RTDs.
The averaged output rate of 20 Hz for all sensor inputs is more than adequate for fast filling / draining of the milk vat:
In reset to then press button.
Display toggles between
Set to
- 2** Select CH1 frequency input of 2 Hz - 1000 Hz for the flow rate sensor:
In select then press button three times.
- 3** Select RTD2 as the vat temperature input for CH2:
In select
- 4** Select RTD3 as the discharge temperature input for CH3:
In select
- 5** Select process input 1 as the milk volume input for CH4:
In select



Note: both RTD inputs (RTD2 and RTD3) and the linear displacement transducer input (Process Input 1) require to be individually calibrated using the controller's 2-point calibration technique.

Example 2:

Application Running a Macro

The IST1 and the IST2 have 5 active smart output registers available. Access to the fifth register (or all registers) can be done through a simple macro string as demonstrated in the example macro below.

First set Code 7 to [000] so that the Result register (&Result) is not updated by any math function. In the example macro below the Main Macro defines the Result register as the 5th smart output register (&SMART_RESULT5). In this way CH1 to CH4 contain the first four smart output registers and the Result contains the fifth.

```
5.bas
Save Undo Compile F7
Macro On/Off Erase Macro
1 //*****
2 //           Smart triple RTD & dual Process Macro
3 //
4 //
5 //           This macro shows how to load the RESULT register with the
6 //           smart output register 5 (2nd process channel).
7 //
8 //
9 MEM &CODE7=000           //sets up the result processing
10
11 Main_Macro:
12   &RESULT = &SMART_RESULT5
13 END
```

Macros are powerful tools used to increase the versatility and range of the Tiger controller beyond the standard code settings. For further information on macros and the registers in the Tiger 320 operating system see the following literature:

- TDS Macro Tutorial (NZ212).
- Registers Supplement (NZ209).

These and other Tiger related documents are freely available on our website at:

www.texmate.com

RTD Full Scale Calibration Procedures

The RTDs can be calibrated in °F or °C. Using a calibration source to calibrate a zero and full scale setting is the easiest method to use. If a calibration source is not available, the known resistance values for the temperatures can be used.

The following table lists the equivalent resistances for both Pt385 and Pt392 type 100 Ω RTDs over a temperature range of 0 to 100 °C.

RTD Type	Temperature	Equivalent Resistance
Type Pt385 / 392	0 °C	100 Ω
Type Pt385	100 °C	138.5 Ω
Type Pt392	100 °C	139.3 Ω

If a calibration source is not available make up a set of calibration plugs with the resistors shown in the diagrams opposite.

Plug the 0 °C calibration plug into the module and program the [ZErO] setting for the first channel required.

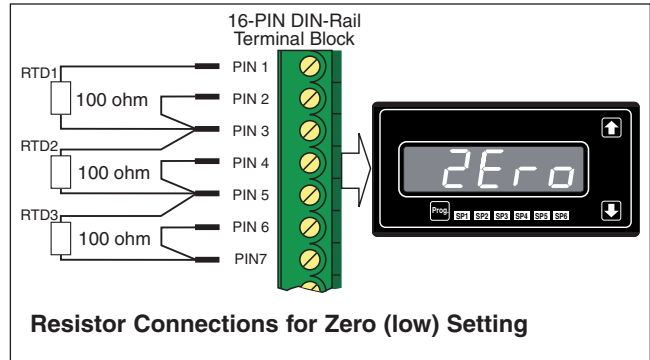

Unplug the 0 °C plug and plug the 100 °C calibration plug into the module and program the [SPAn] setting for the same channel.

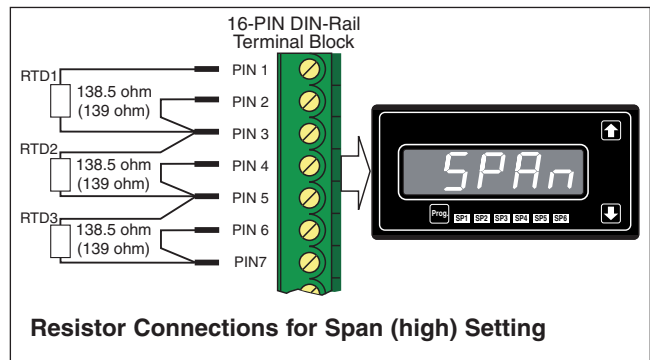

Example 2-point Calibration Procedure

The example 2-point calibration procedure on Page 11 can be used with a calibration source or with the calibration plug method. Enter the calibration mode and carry out the 2-point calibration procedure on the first channel required for RTD input.

Repeat this procedure for any other channels requiring an RTD input.

Tiger Macro Development System (TDS)

Tiger 320 Macro Overview

The Tiger 320 Series of programmable meter controllers have been designed to incorporate the analog and digital functionality of an intelligent controller with the logic of a PLC.

Traditionally, the PLC approach is to build a working application entirely in some form of programming language. The approach used in the Tiger 320 Series of controllers is to build an application by selecting the pre-programmed functions of the controller and then adding small amounts of programmability and logic where needed.

The operating system of the Tiger 320 controller controls all the pre-programmed functions, handling the input, averaging, scaling, linearization, totalization and much more, as well as driving the display, timers, relays, analog and serial outputs. Once configured, these functions are executed by the operating system and form the basis of a control system.

To form an advanced automation and control system you only need to write a small program that adds the extra logic required. We call this program a macro. A macro can be written specifically for your application and is used to initiate a sequence, reconfigure, or disable some of the controller functions. With Texmate's 22 I/O plug-in module installed, a macro further expands the Tiger 320 operating system with additional digital status inputs and digital switched outputs.

START HERE

2-point Calibration Mode Example

Step 1

Enter the brightness mode

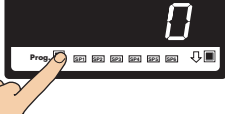
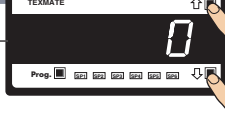
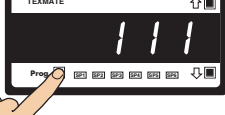
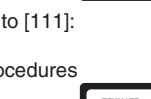
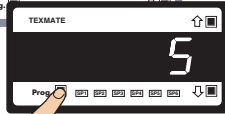
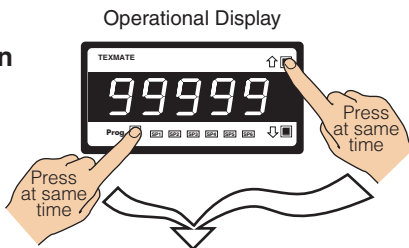

Step 2

Pass the brightness mode and the enter calibration mode

Step 3

Set calibration mode to [111]:
1st Digit = 1
Selects calibration procedures
2nd Digit = 1
Selects 2-point calibration
3rd Digit = 1
Selects CH1 for calibration

[111] for CH1
[112] for CH2
[113] for CH3
[114] for CH4

Step 4

Enter calibration mode [111] for 2-point calibration of CH1

Step 5

5.1. Adjust display to desired reading for zero input
5.2. Apply the LOW input signal, or connect the 0 °C plug to the module

LOW Signal

Example

To Step 7

Step 7

7.1. Adjust display to desired reading for span input
7.2. Apply the HIGH input signal, or connect the 100 °C plug to the module

HIGH Signal

Example

Step 8

Save zero and span settings and re-enter calibration mode

Step 9

Select the no function calibration mode [000]

Step 10

Save calibration mode [000] setting and enter Code 1

Step 11

Exit Code 1 and return to the operational display

Operational Display

Macro control is ideal for many OEM applications that require analog, digital, and timer functions with sophisticated mathematical and enhanced logic operations. The macro concept has major cost advantages for large or small sophisticated applications that require some degree of programmable logic control with display and front panel control.

Custom Macro Programming

Texmate's Tiger Development System (TDS) enables a macro to be written and compiled in BASIC, utilizing any combination of the hundreds of functions and thousands of registers embedded in the Tiger 320 Operating System. When your BASIC program is compiled into Tiger 320 Macro-language it is error checked and optimized.

Macros are useful when implementing a specialized control system that cannot be achieved by the standard configuration capability of the Tiger 320 Operating System. Using the TDS software, functions can be altered or added in a standard controller to perform the required job. This may typically include logic sequencing functions and mathematical functions.

Developing a Macro is much easier and quicker than programming a PLC, because the basic code required to customize the Tiger meter is considerably less than the ladder logic programming required for PLCs. This is due to the hundreds of functions built into the Tiger controller that can be manipulated or invoked by a macro to fulfill the requirements of almost any application.

Scrolling display messages can be programmed to appear with any setpoint activation, selected event, or logic input. Easy to read, plain text prompts can be programmed to replace the manual programming codes and provide a user-friendly interface for any custom application.

Scrolling Text Messaging

Scrolling text messaging is another bonus from running a macro. Any number of messages for detailed operator instructions, of up to 100 characters each, can be written into the macro during compilation for detailed operator instructions, alarm and control applications.

A scrolling text message can be written for OEMs and sensor manufacturers providing informative instructions for setup and calibration procedures.



Alphanumeric Displays

14-segment alphanumeric displays are Texmate's display choice for easy to read display text and scrolling text messaging.

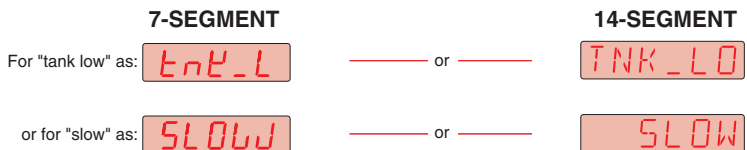

Customer Configuration Settings:

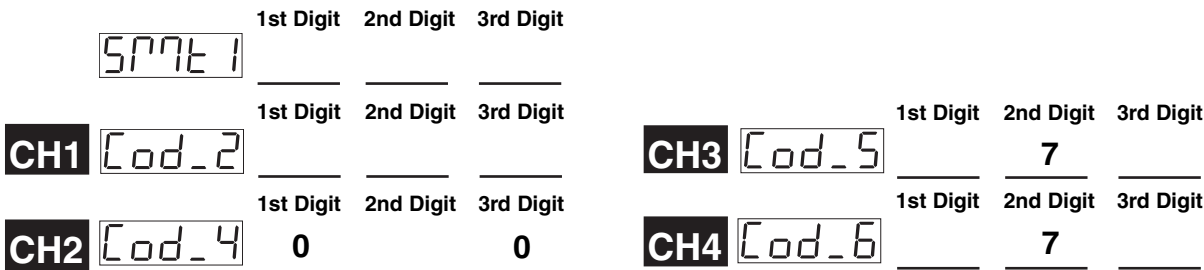

WARRANTY

Texmate warrants that its products are free from defects in material and workmanship under normal use and service for a period of one year from date of shipment. Texmate's obligations under this warranty are limited to replacement or repair, at its option, at its factory, of any of the products which shall, within the applicable period after shipment, be returned to Texmate's facility, transportation charges pre-paid, and which are, after examination, disclosed to the satisfaction of Texmate to be thus defective. The warranty shall not apply to any equipment which shall have been repaired or altered, except by Texmate, or which shall have been subjected to misuse, negligence, or accident. In no case shall Texmate's liability exceed the original purchase price. The aforementioned provisions do not extend the original warranty period of any product which has been either repaired or replaced by Texmate.

USER'S RESPONSIBILITY

We are pleased to offer suggestions on the use of our various products either by way of printed matter or through direct contact with our sales/application engineering staff. However, since we have no control over the use of our products once they are shipped, NO WARRANTY WHETHER OF MERCHANTABILITY, FITNESS FOR PURPOSE, OR OTHERWISE is made beyond the repair, replacement, or refund of purchase price at the sole discretion of Texmate. Users shall determine the suitability of the product for the intended application before using, and the users assume all risk and liability whatsoever in connection therewith, regardless of any of our suggestions or statements as to application or construction. In no event shall Texmate's liability, in law or otherwise, be in excess of the purchase price of the product.

Texmate cannot assume responsibility for any circuitry described. No circuit patent or software licenses are implied. Texmate reserves the right to change circuitry, operating software, specifications, and prices without notice at any time.



1934 Kellogg Ave. • Carlsbad, CA 92008
 Tel: 1-760-598-9899 • USA 1-800-839-6283 • That's 1-800-TEXMATE
 Email: orders@texmate.com • Web: www.texmate.com

For product details visit www.texmate.com